

FIRE PROTECTION FOR GAS TURBINES AND ELECTRIC GENERATORS

Table of Contents

	Page
1.0 SCOPE	3
1.1 Changes	3
2.0 LOSS PREVENTION RECOMMENDATIONS	3
2.1 Introduction	3
2.1.1 Management of Fire Hazards	3
2.2 Construction and Location	3
2.2.1 General	3
2.2.2 Roof Materials (Turbine Buildings)	4
2.2.3 Protection of Structural Steel	4
2.2.4 Containment and Emergency Drainage	5
2.2.5 Lubrication, Hydraulic, and Seal Oil Systems	6
2.2.6 Fuel Supply	8
2.2.7 Lubrication, Control, and Seal-Oil Piping	8
2.2.8 Hydrogen Supply for Electric Generator Cooling	9
2.2.9 Fuel Piping	10
2.2.10 Electrical Rooms and Transformers	10
2.2.11 Control Rooms and Associated Equipment	10
2.3 Occupancy	11
2.3.1 Housekeeping	11
2.3.2 FM Approved Industrial Fluids	11
2.3.3 Hydrogen Supply for Electric Generator Cooling	11
2.3.4 Grouped Cables and Cable Spreading Rooms	11
2.3.5 Earthquake	12
2.4 Protection	12
2.4.1 Fuel Leak Detection	12
2.4.2 Fire Detection for Turbine Compartments	12
2.4.3 Fire Protection for Turbine, Generator, and Auxiliary Compartments	13
2.4.4 Fire Protection for Turbine Buildings	15
2.4.5 Water Mist Systems for Oil Fire Hazards in Unenclosed Areas	19
2.4.6 Combustible Roof Protection	21
2.4.7 Relay and Cable Spreading Rooms and Transformers	21
2.4.8 Control Rooms and Distributed Control System (DCS) Rooms	21
2.5 Equipment and Processes	21
2.5.1 Fuel Protective Systems	21
2.5.2 Fuel Supply and Proof-of-Flame	21
2.6 Operation and Maintenance	24
2.6.1. Fire Prevention	24
2.6.2 Emergency Shutdown Procedures	24
2.6.3 Spray Fire Shield Inspection and Maintenance	24
2.6.4 Oil Fire Hazards Assessment (OFHA)	25
2.6.5 Fuel Supply	25
2.7 Training	26
2.7.1 Employee Training	26
2.7.2 Contractor Training	26
2.8 Human Factor	27



2.8.1 Supervision of Programs	27
2.8.2 Supervision of Contractors	27
2.8.3 Plant Inspections	27
2.8.4 Emergency Response and Pre-Incident Planning	27
2.8.5 Audits and Management of Change	28
2.9 Ignition Source Control	28
2.9.1 Hot Work	28
2.9.2 Other Ignition Sources	28
2.9.3 Inlet Air Filters and Evaporative Coolers	28
3.0 SUPPORT FOR RECOMMENDATIONS	28
3.1 General	28
3.1.1 Release Sources	29
3.1.2 Ignition Sources	30
3.1.3 Oil Fire Hazards	30
3.1.4 Approved Industrial Fluids	30
3.1.5 Oil Fire Hazards Assessment (OFHA)	31
3.2 Location and Construction Safeguards	34
3.2.1 Site Layout and Equipment Arrangements	34
3.2.2 Structural Steel Protection	34
3.2.3 Spill Containment and Emergency Drainage	34
3.3 Automatic Fire Protection	34
3.3.1 Fuel Leak Detection	35
3.3.2 Special Extinguishing Systems	35
3.3.3 Automatic Sprinkler Systems	36
3.4 Emergency Shutdown Procedure	36
3.5 Fuel Supply System	37
3.5.1 Fuel Shutoff Valve Leakage	37
3.5.2 Fuel Shutoff Valve Leakage Testing	37
4.0 REFERENCES	38
4.1 FM	38
4.2 Other	39
APPENDIX A GLOSSARY OF TERMS	39
APPENDIX B DOCUMENT REVISION HISTORY	41

List of Figures

Fig. 2.2.3. Water spray protection for steel columns	4
Fig. 2.2.4.1. Schematic example of emergency drainage and containment system for unenclosed combustion turbine installation	5
Fig. 2.2.5.3. Cable protection for dc lube oil pump	6
Fig. 2.2.5.4.1. Lube oil purifying skid inside containment area	7
Fig. 2.2.7.1 Guard piping	9
Fig. 2.4.3.1. Enclosed gas turbine protection system	13
Fig. 2.4.4. Schematic of fire protection system for unenclosed gas turbine installation	16
Fig. 2.4.4.2.2(A). Roof level sprinkler option	17
Fig. 2.4.4.2.2(B). Local sprinkler option	18
Fig. 2.4.5.2.1. Typical layout of water mist system for local application over oil fire hazards. [NOTE: Shaded areas are not solid barriers, but areas of operation.]	20
Fig. 2.5.2.1.1. Typical gaseous fuel system (double block and vent)	22
Fig. 2.5.2.1.2(A). Gaseous fuels (triple block and double vent)	22
Fig. 2.5.2.1.2(B). Gaseous fuels (triple block, double vent, and pressurized pipe section)	22
Fig. 2.5.2.3.1. Typical liquid fuel system (double block and drain)	23
Fig. 3.1.1. Lube-oil release source: broken supply line	29
Fig. 3.1.3. Mineral oil spray fire (90 psig [6 barg]) demonstration test performed by FM	31
Fig. 3.1.5. Oil-release and fire scenario checklist	33

List of Tables

Table 1. Sprinkler Densities for Roof-Level and Local Protection Options	18
Table 2. Ceiling Sprinkler Design Criteria for Turbine Buildings with Combustible Roof Construction	21

1.0 SCOPE

This data sheet recommends safeguards to protect gas turbine installations against property damage and loss of production due to fires. For combined cycle power generation installations, use this data sheet for the gas turbines and Data Sheet 7-101, *Fire Protection for Steam Turbines and Electric Generators*, for the steam turbines. For information regarding driven equipment other than electric generators, use this data sheet in conjunction with other applicable data sheets (e.g., refer to Data Sheet 7-95, *Compressors*, for information on compressors). Finally, refer to Data Sheet 13-17, *Gas Turbines*, for recommendations regarding turbine monitoring devices, maintenance and testing, and information regarding other equipment hazards.

1.1 Changes

April 2026. Interim revision. Minor editorial changes were made.

2.0 LOSS PREVENTION RECOMMENDATIONS

2.1 Introduction

Severe fires in gas turbine installations can occur as a result of the accidental release and ignition of fuel or lubrication, control, or seal oil systems. Such fires can cause forced outages and result in extensive damage to inadequately protected turbine units and building structures. The safeguards recommended in this data sheet address gas turbine fire hazards using the following basic prevention and mitigation strategies:

- A. Fire prevention incorporated into operating procedures and training
- B. Location and construction designed to isolate and limit the fire area
- C. Fixed automatic protection in all areas where fires could occur
- D. An effective emergency shutdown system for the turbine
- E. Personnel preparedness for effective response in fire emergencies

The recommendations in this data sheet are based on conservative assumptions regarding the severity of the initiating events that could result in turbine fires. The isolation and protection criteria for lubrication oil fires are intended for large releases, as may occur following mechanical breakdown of equipment. Such releases have occurred in the past and can potentially occur at any given turbine unit despite the best efforts at prevention. This data sheet also considers other gas turbine hazards, such as high-pressure gas piping and potential explosions within gas turbine compartments. Loss experience has shown that the mitigation measures recommended in this data sheet can help prevent the majority of fire and explosion losses, even in the case of severe initiating events.

Use FM Approved equipment, materials, and services whenever they are applicable. For a list of products and services that are FM Approved, see the *Approval Guide*, an online resource of FM Approvals.

2.1.1 Management of Fire Hazards

Successful implementation of the recommendations in this data sheet requires ongoing management support and oversight to address a wide range of related technical and organizational issues.

2.1.1.1 Establish a documented property conservation policy supporting the provision of all appropriate safeguards against gas turbine fire hazards. See Data Sheet 9-7, *Property Conservation*, for general recommendations relating to developing property conservation policies and loss prevention programs.

2.1.1.2 Conduct recorded internal audits and provide management reporting channels to ensure loss prevention programs are implemented as intended.

2.2 Construction and Location

2.2.1 General

2.2.1.1 Locate gas turbines in buildings constructed of noncombustible or fire-resistant materials.

2.2.1.2 Where a new turbine unit is located inside or attached to a main building occupied for another purpose, such as manufacturing, offices or warehousing, provide 2-hour fire-rated cut-offs and direct access to the turbine from outside the main building.

2.2.1.3 Provide space separation, fire walls, curbing, and/or emergency drainage to prevent a fire in one unit from exposing adjacent equipment.

2.2.1.4 Install transformers that expose inlet air filters in accordance with Data Sheet 5-4, *Transformers*.

2.2.1.5 Provide ready access for hose streams to fight inlet air-filter fires.

2.2.2 Roof Materials (Turbine Buildings)

Provide a noncombustible roof or an FM Approved Class 1 steel deck roof, designed and installed per Data Sheet 1-29, *Roof Securement and Above-Deck Roof Components*, and the roof system's *Approval Guide* listing.

2.2.3 Protection of Structural Steel

Protect critical steel elements that can potentially be immersed in a liquid pool fire and/or three-dimensional spill fire, such as structural building columns and supports for equipment mezzanines, using one of the methods below. Determine the need for structural steel protection based on an Oil Fire Hazards Assessment (Section 2.6.4), including consideration of containment, drainage, and oil-release scenarios:

A. Provide fireproofing rated for two hours. Provide fireproofing that is rated for a hydrocarbon fire exposure for the full height of the column. (See Data Sheet 1-21, *Fire Resistance of Building Assemblies*)

B. Provide automatic (fusible link) sidewall sprinklers or water spray protection for the full height of the column, as shown in Figure 2.2.3.

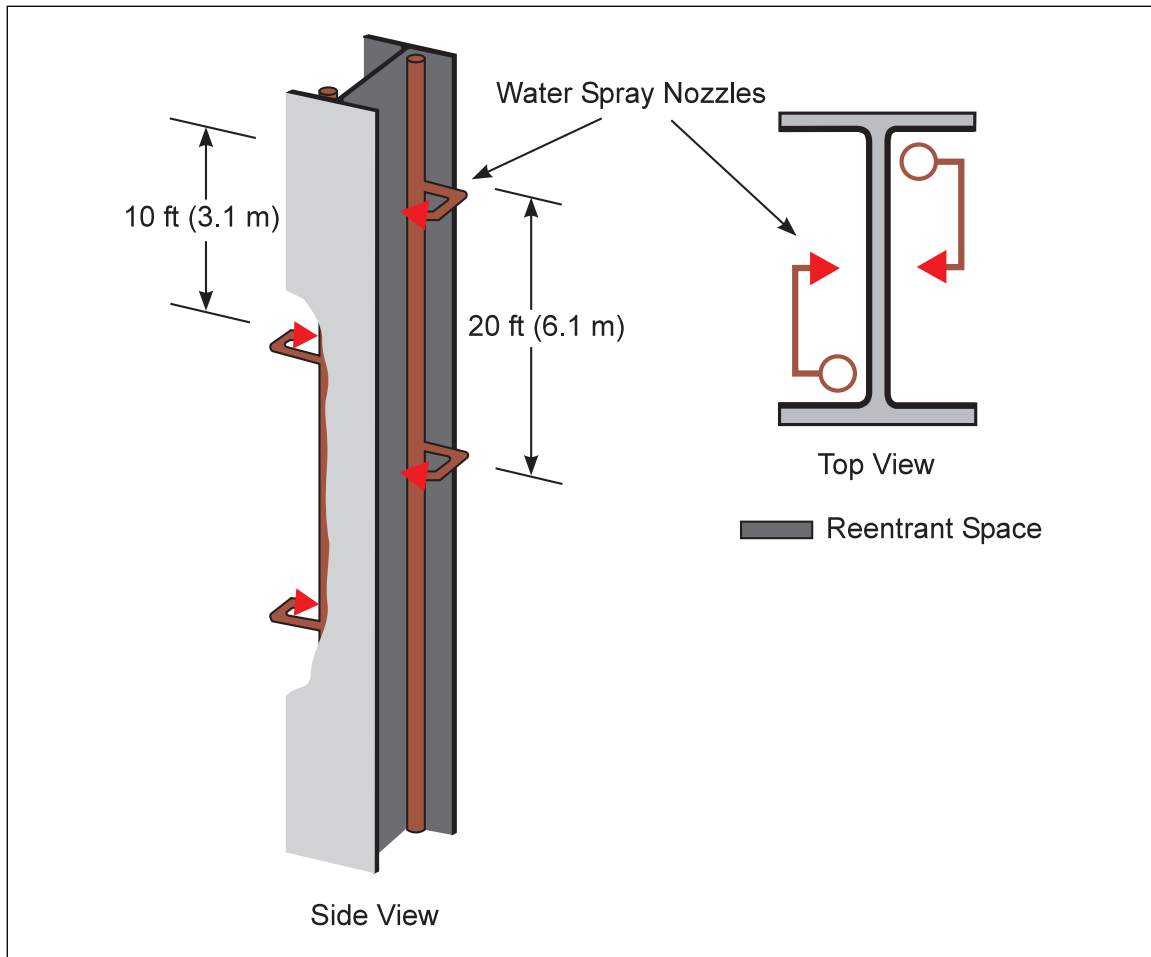

Fig. 2.2.3. Water spray protection for steel columns

Provide a minimum 0.3 gpm/ft² (12 mm/min) over the wetted area of the column (“wetted area” is the surface area on the three sides of the reentrant space formed by the column web and flanges). The wetted area protected by a sprinkler extends from the sprinkler down to the next sprinkler on the same side of the column.

Include flow from all nozzles on columns subject to simultaneous flame impingement in the design flow rate when determining total water demand. Use information from an Oil Fire Hazards Assessment to determine which columns could be subject to simultaneous flame impingement. Consider simultaneous operation of structural steel protection and turbine lube-oil fire protection to determine total water demand (refer to Section 2.4.4.1.1).

2.2.4 Containment and Emergency Drainage

2.2.4.1 Provide engineered emergency drainage and containment to limit fire areas and protect important turbine installations against fires involving releases of fuel or lubrication oil and hydraulic fluids that are not FM Approved. Provide one of the following three options.

- A. Provide containment and emergency drainage arranged to achieve the following objectives:
 1. Rapidly remove released liquids, including the oil flow rate and water from sprinkler discharge, to a safe location outside of the turbine compartment and the turbine building.
 2. Provide curbing and drains to a safe location for potential liquid releases from fuel, lubrication, seal, and hydraulic fluid reservoirs and pump enclosures.
 3. Use drains and curbs to prevent releases from flowing to and exposing adjacent equipment areas such as auxiliary equipment skids and compartments, cable trays and electrical switchgear, and subfloor spaces. Refer to Figure 2.2.4.1 for an example of an emergency drainage and containment system.
 4. Prevent fire from spreading to unsprinklered areas.

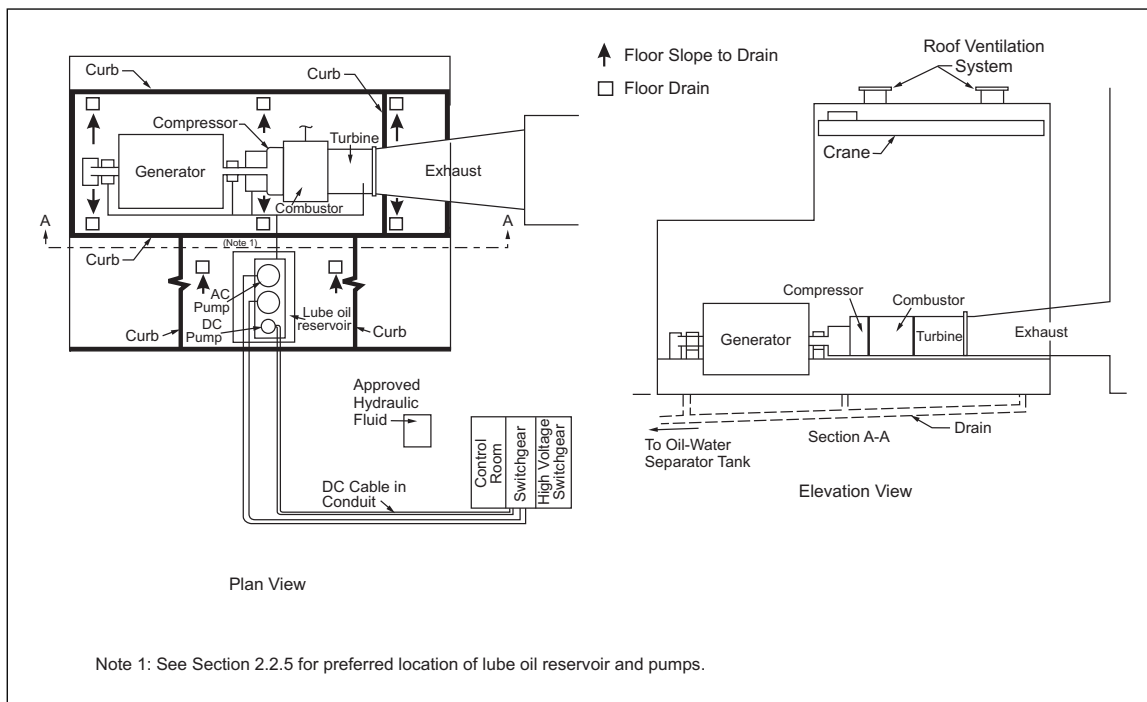

Fig. 2.2.4.1. Schematic example of emergency drainage and containment system for unenclosed combustion turbine installation

- B. Provide containment and an FM Approved foam-water sprinkler system or compressed air foam (CAF) system. Design the containment to keep the largest expected oil release plus foam/sprinkler discharge in the area of origin for 20 minutes. Regardless of the calculated curb height, always provide a minimum 3 in. (7.6 cm) of containment.

2.2.4.2 Design emergency drainage and containment systems in accordance Data Sheet 7-83, *Drainage Systems for Ignitable Liquids*.

2.2.5 Lubrication, Hydraulic, and Seal Oil Systems

Provide the following location and construction safeguards where mineral oil or other non-FM Approved fluids are used.

2.2.5.1 Locate lubrication and control-oil systems, including reservoirs, storage tanks, conditioning equipment (coolers, oil filtration, and centrifuge systems), and pumps in a separate fire area from the turbine. Provide at least 1-hour fire-rated construction.

2.2.5.2 Locate any indoor main lube-oil storage tanks in a separate cutoff room in accordance with Data Sheet 7-88, *Ignitable Liquid Storage Tanks*.

2.2.5.3 Where applicable, make the following provisions for power and control cables for critical functions such as lubrication of the turbine and power for hydrogen seal-oil pumps:

- A. Route the cables to minimize exposure to potential oil fires.
- B. Locate control and instrumentation cable for individual units to minimize the chance a fire will result in an extended outage to multiple units.
- C. Provide separate routing for cables for primary and backup lube-oil pumps (see Figure 2.2.5.3).
- D. Provide an FM Approved fire blanket for backup cables (DC) that cannot be routed separately, and for cables that enter within the same pool or spill-fire area, including cabling within conduit.
 1. Provide a blanket that has a fire protection rating equal to or greater than the maximum projected time for safe shutdown of the system plus 10 minutes.
 2. Document the fire rating and methodology in the emergency operating procedure.
 3. Ensure the fire blanket includes the flexible conduit used to route the cables from the pump to the junction box.
 4. Provide the fire blanket for 20 ft (6.1 m) beyond the fire area (see Figure 2.2.5.3). Verify the blanket will not result in cable de-rating.

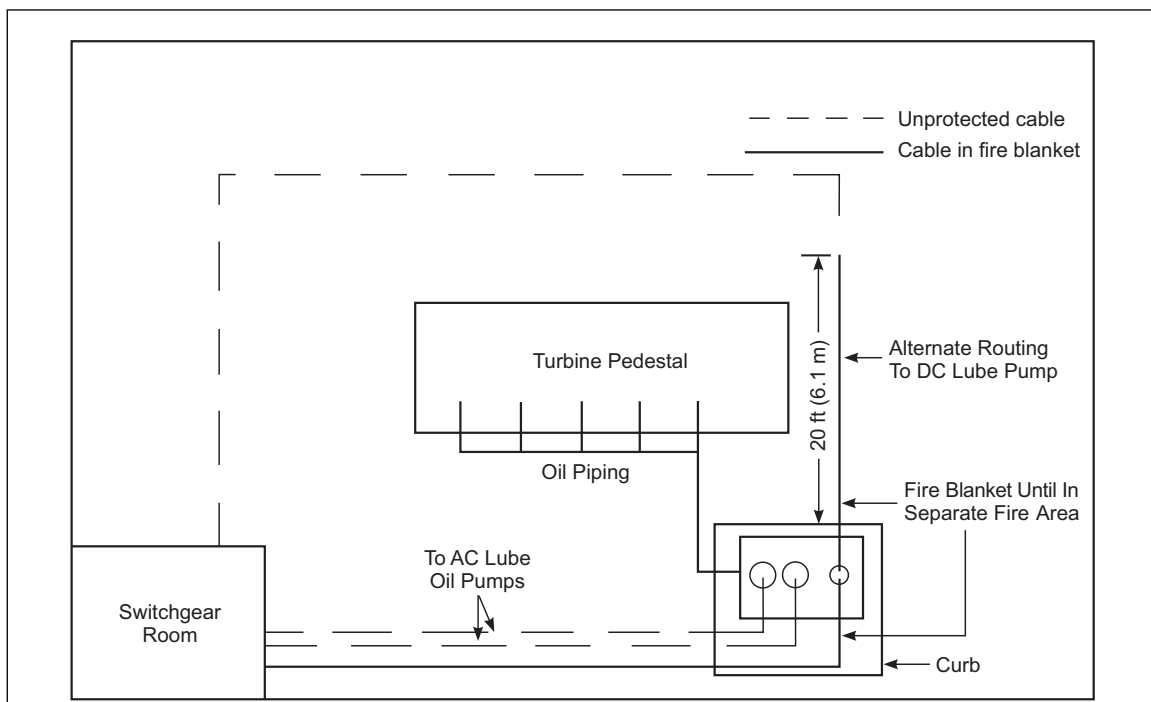

Fig. 2.2.5.3. Cable protection for dc lube oil pump

2.2.5.4 Oil Conditioning, Purifying, Cleaning or Varnishing Skids

2.2.5.4.1 Install skids used for oil conditioning within the protected fire area of the lube oil skid (see Figure 2.2.5.4.1).



Fig. 2.2.5.4.1. Lube oil purifying skid inside containment area

2.2.5.4.2 Install skid within the lube oil containment area, or provide separate containment for the skid. If separate containment is used, install an FM Approved leak detection system on the feed side to the polisher arranged to automatically shut down oil flow in the event of a leak.

2.2.5.4.3 If the skid is not located within the oil fire protected area, provide fire protection over the oil conditioning skid in accordance with the spray or pool fire recommendations as applicable.

2.2.5.4.4 Install FM Approved fire safe, fire-actuated valves for feed and discharge lines to and from the oil-conditioning skid. Locate these valves within the main lube oil tank containment area.

2.2.5.4.5 Provide flexible hose connectors in piping systems to prevent dangerous stresses due to vibration, settling, or thermal change. Provide the following material and installation features to ensure adequate hose strength/ durability and protection against physical damage:

- A. Construct flexible hose of high-strength, noncombustible materials that are resistant to decomposition or melting when exposed to fire, and compatible with the liquid in use.

1. Use all-metal construction consisting of materials such as steel, stainless steel, or an equivalent material.
2. Reinforced plastic or rubber hose, and a tight metal-braid covering is acceptable when needed to meet operational requirements. See Data Sheet 7-32, *Ignitable Liquid Operations*, for further information.
3. Do not use soft rubber, plastic, or other unreinforced or unprotected combustible tubing.

B. Protect the hose against mechanical damage.

C. Design hose joints to comply with all rigid pipe joint recommendations (see Data Sheet 7-32, *Ignitable Liquid Operations*). Do not use hose clamps.

D. Design hoses and fittings to have a bursting strength greater than the maximum expected working pressure with a safety factor of at least 4.

2.2.6 Fuel Supply

2.2.6.1 For information regarding emergency power generation systems, refer to Data Sheet 5-23, *Design and Protection for Emergency and Standby Power Systems*.

2.2.6.2 Locate and arrange primary liquid fuel storage and pumps in accordance with Data Sheet 7-88, *Ignitable Liquid Storage Tanks*, and Data Sheet 7-32, *Ignitable Liquid Operations*.

2.2.6.3 Where separate fuel pumps are located indoors, provide a 1-hour fire-rated cutoff room with appropriate emergency drainage and containment (see section 2.2.4) to remove fuel spills to a safe location outside the building and away from important equipment.

2.2.6.4 Locate storage tanks and vaporizers for liquefied petroleum gas fuel systems in accordance with Data Sheet 7-55, *Liquefied Petroleum Gas (LPG) in Stationary Installations*.

2.2.6.5 Where fuel is heated using an organic heat transfer fluid, locate and arrange the system in accordance with Data Sheet 7-99, *Heat Transfer Fluid Systems*.

2.2.6.6 Locate fuel gas compressor stations in open outdoor areas or in detached buildings of damage-limiting construction in accordance with Data Sheet 1-44, *Damage-Limiting Construction*, and Data Sheet 7-95, *Compressors*. Locate high-pressure gas piping aboveground and arrange it in accordance with American National Standard B31.1, *Power Piping*, B31.3, *Process Piping Guide*, or applicable international standards.

2.2.6.7 Arrange piping systems located in 500-year or less earthquake zones in accordance with Data Sheet 1-2, *Earthquakes*.

2.2.6.8 Provide emergency fuel shutoff valves where they will be readily accessible in the event of emergencies.

2.2.7 Lubrication, Control, and Seal-Oil Piping

2.2.7.1 Design and install oil piping to minimize chances of a break in a pipe or fitting in the event of turbine vibration.

A. Weld piping for lubricating and control-oil systems where possible.

B. Install supply piping inside drain or guard piping (Figure 2.2.7.1), inside steel welded enclosures, or in covered trenches designed to return oil leakage to a protected collection point.

C. Properly support and brace oil piping and protect instruments, controls and associated fittings against mechanical damage.

2.2.7.2 Rubber Expansion Joint (Bellows)

Rubber bellows have been installed on some lube-oil supply systems. They may be installed anywhere in supply-oil piping for alignment purposes or to reduce vibration. Failure of rubber bellows, either from external fire exposure or from wear, has resulted in significant releases of oil.

A. Replace rubber bellows with a metal expansion joint or stainless steel braided hose. Consult the turbine manufacturer for recommended equipment.

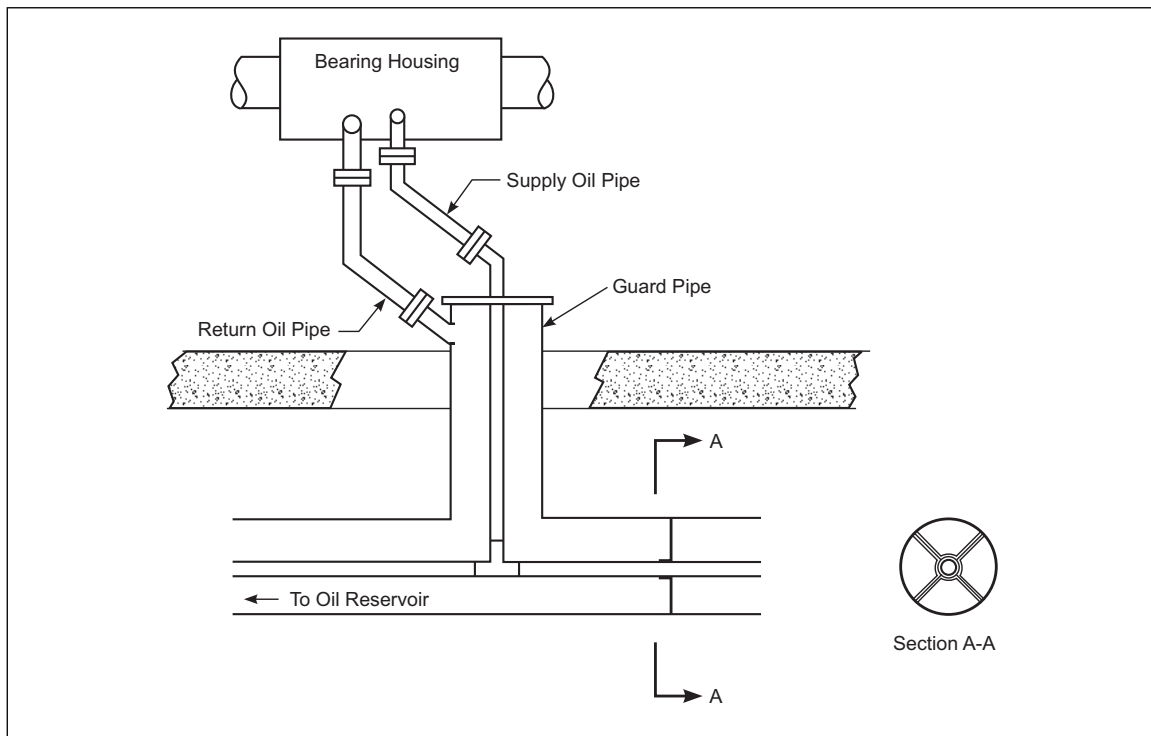

Fig. 2.2.7.1 Guard piping

B. Provide a containment device (sleeve) around the rubber bellows until the bellows can be replaced.

2.2.7.3 Provide unlatched hinged covers for oil tanks associated with hydrogen seal-oil equipment.

2.2.7.4 Earthquake

2.2.7.4.1 In areas exposed by earthquakes, do not install seismic shutoff switches for lube-oil systems. Refer to Data Sheet 1-11, *Fire Following Earthquake*, for further information regarding the omission of seismic shutoff valves.

2.2.7.4.2 Design oil piping systems to resist damage in the event of an earthquake as follows:

- A. Limit gross movement of the equipment to which the piping is connected.
- B. Provide flexibility to accommodate relatively small movement at equipment, or larger movement due to piping deflection.
- C. Ensure pipe movement does not result in loss of vertical supports.

2.2.8 Hydrogen Supply for Electric Generator Cooling

Where hydrogen-cooled generators are used, hydrogen gas may be supplied from standard portable cylinders, outdoor tanks or tube trailers, or from an onsite hydrogen gas generator. The following recommendations pertain to fire protection for the hydrogen supply.

2.2.8.1 Locate bulk hydrogen tanks and hydrogen tube trailers outdoors and arrange them in accordance with Data Sheet 7-91, *Hydrogen*.

2.2.8.2 Preferably, store portable cylinders outside under a fenced, access-controlled canopy. Alternatively, they may be stored in a secure, detached building in accordance with Data Sheet 7-50, *Compressed Gases in Portable Cylinders and Bulk Storage*.

2.2.8.3 If portable cylinders are to be stored inside an important building, provide a cutoff room with damage-limiting construction (DLC), continuous mechanical ventilation, gas detection, and sprinkler protection in accordance with Data Sheet 7-50, *Compressed Gases in Portable Cylinders and Bulk Storage*.

2.2.8.4 In 500-year or less earthquake zones, restrain hydrogen cylinders in accordance with Data Sheet 1-11, *Fire Following Earthquake*.

2.2.8.5 If dispensing manifolds for portable cylinders are located inside the main facility, arrange them in accordance with Data Sheet 7-91, *Hydrogen*. Ensure the cylinders are not exposed to lubricating-oil fires.

2.2.8.6 Provide human-element safeguards for hydrogen cylinders in accordance with Data Sheet 7-50, *Compressed Gases in Portable Cylinders and Bulk Storage*.

2.2.8.7 Where hydrogen gas for electric-generator cooling is being produced on site, locate the gas generators outdoors or, if located indoors, in accordance with Data Sheet 7-91, *Hydrogen*.

2.2.8.8 Install an emergency shutoff valve on the hydrogen supply line. Locate the emergency shutoff valve close to the supply manifold at a readily accessible location. Also provide for remote emergency operation of the shutoff valve from the control room.

2.2.8.9 In 500-year or less earthquake zones, do not install seismic gas shutoff valves for the hydrogen supply. Refer to Data Sheet 1-11, *Fire Following Earthquake*, for further information regarding seismic shutoff valves.

2.2.8.10 Design hydrogen piping systems to resist damage in the event of an earthquake in accordance with Section 2.2.7.4.2.

2.2.9 Fuel Piping

2.2.9.1 Design gas piping systems in accordance with Data Sheet 7-54, *Natural Gas and Gas Piping*.

2.2.9.2 Design liquid fuel piping systems in accordance with Data Sheet 7-32, *Ignitable Liquid Operations*.

2.2.10 Electrical Rooms and Transformers

2.2.10.1 Locate control, instrumentation, and switchgear equipment in 1-hour fire-rated enclosures outside of areas subject to fire involving turbine fuel oil or lubrication fluids.

2.2.10.2 Seal openings in floors, walls, and ceilings with an FM Approved fire-stop of 1-hour fire resistance.

2.2.10.3 Seal the walls and ceilings of exposed instrumentation and electrical rooms to prevent ingress of liquid spills and water from sprinkler/hose stream discharge.

2.2.10.4 Locate and arrange transformers in accordance with Data Sheet 5-4, *Transformers*.

2.2.11 Control Rooms and Associated Equipment

Design control rooms to minimize potential exposure damage, and to remain habitable during a fire to allow operators to secure the turbine(s).

2.2.11.1 Locate control and cable spreading rooms in separate areas of noncombustible construction, detached from turbine enclosures and turbine buildings.

2.2.11.2 When a control room must be sited inside or attached to turbine buildings, design the room as follows:

- A. Locate the control room so as to reduce exposure to potential lube-oil, fuel, or grouped cable fires.
- B. Isolate the room from the turbine building with 1-hour fire-rated walls, roof, and floor. Provide a 45-minute fire-rated window assembly, such as wired glass, rolling steel fire-rated shutters, or an automatic water spray protection system for any windows facing the interior of the turbine building.
- C. Provide smoke-tight sealing of windows and an independent air supply capable of pressurizing the room to maintain habitability during a fire.
- D. Seal the walls and ceilings of exposed control rooms inside turbine buildings to prevent ingress of facility water or other liquids in case of pipe breaks, spills, or water from sprinkler/hose stream discharge.
- E. Seal penetrations between the control, cable spreading, and relay rooms with a 1-hour fire-rated, FM Approved fire-stop system. Conduct recorded inspections to confirm penetrations are properly sealed.
- F. Ensure equipment needed to safely shut down the turbine(s) is arranged for remote operation from the control room.

2.2.11.3 The recommendations in Section 2.2.11.2 provide sufficient segregation and protection of the control room from a property protection standpoint. However, depending on the location and design of the control room, a facility may need to consider additional life safety issues, which are outside the scope of this data sheet. Where the control room is not designed to allow operators to remain and secure the turbines during a fire, arrange for emergency shutdown of the turbine and lube-oil pumps from a location that will be accessible.

2.2.11.4 Provide 1-hour fire-rated walls, floors, and ceilings for cable spreading and relay rooms.

2.3 Occupancy

2.3.1 Housekeeping

Maintain high standards of housekeeping in all areas.

2.3.1.1 Conduct periodic recorded housekeeping inspections.

2.3.1.2 Provide a management reporting channel for prompt correction of housekeeping deficiencies.

2.3.1.3 Store flammable gas cylinders in a detached, dedicated area in accordance with DS 7-50, *Compressed Gases in Portable Cylinders and Bulk Storage*.

2.3.1.4 Store drums of lubricating or hydraulic oils outside of the turbine enclosure and turbine building or in a cutoff room located and constructed in accordance with DS 7-29, *Ignitable Liquid Storage in Portable Containers*.

2.3.1.5 Provide FM Approved cabinets for small containers of ignitable liquids.

2.3.2 FM Approved Industrial Fluids

2.3.2.1 Use FM Approved hydraulic (industrial) fluid in the turbine control system, rather than mineral oil. Consult the original equipment manufacturer (OEM) in selecting a suitable FM Approved fluid.

2.3.2.2 Refer to Data Sheet 7-98, *Hydraulic Fluids*, for additional information regarding the conversion of equipment from mineral oil-based hydraulic fluids to FM Approved fluids.

2.3.3 Hydrogen Supply for Electric Generator Cooling

2.3.3.1 Provide a system of emergency venting and purging of hydrogen-cooled generators that will be accessible during a fire. Initiate venting and purging of the system with operation of the emergency shutoff valve.

2.3.3.2 Monitor hydrogen gas make-up flow rates and purity, and establish procedures to promptly respond to any unexpected changes.

2.3.4 Grouped Cables and Cable Spreading Rooms

2.3.4.1 Arrange grouped cables as follows:

A. Locate and arrange grouped cables in accordance with Data Sheet 5-31, *Cables and Bus Bars*. Provide a minimum vertical separation of 18 in. (46 cm) between stacked cable trays (see Data Sheet 5-31, *Cables and Bus Bars*).

B. Locate cable trays to avoid or reduce exposures from oil piping as far as practical. Where separation is not possible, locate trays above adjacent oil piping and away from potential three-dimensional spills so trays do not provide channels to spread burning oil.

C. Locate power cables above trays containing control and instrumentation cables.

D. Seal openings in floors, walls, and ceilings through which cables and piping pass from one fire area to another with an FM Approved fire-stop of 1-hour fire resistance. Pay special attention to penetrations into the control room, relay room, and cable spreading room.

E. Keep combustible material out of cable trays. Use covers to protect exposed cable trays, where accumulation of combustible material is possible.

F. Provide a fire-resistive barrier below the bottom tray where cable trays are exposed from oil fires below. This barrier, in addition to automatic sprinkler protection, will limit fire damage to cables.

2.3.5 Earthquake

2.3.5.1 In 500-year or less earthquake zones, anchor electrical cabinets and storage racks in accordance with Data Sheet 1-11, *Fire Following Earthquake*.

2.4 Protection

Provide the following fire protection for turbine compartments and turbine buildings where fire could result in significant property damage or loss of production.

2.4.1 Fuel Leak Detection

2.4.1.1 For turbines capable of running on gaseous fuels, install FM Approved gas detectors designed to initiate alarm signals and automatic emergency shutdown in case of fuel gas detection in the immediate surroundings of the turbine and the fuel gas skid. Adhere to the following recommendations:

- A. Interlock the leak-detection system to trip the turbine and shut off the gas supply by means of a fast-acting shutoff valve located outside of the turbine compartment or the turbine building.
- B. Establish alarm and trip "set points" below 25% of the lower explosive limit (LEL) of the fuel and at the lowest feasible gas concentration level to avoid spurious trips.
- C. Where the turbine is inside a room or compartment, also provide gas detection interlocks to operate dampers and fans to cause all exhaust to be discharged outdoors and away from any important equipment or building air intakes.
- D. Additional guidance is provided in Data Sheet 5-48, *Gas and Vapor Detectors and Analysis Systems*.

2.4.1.2 For units capable of running on liquid fuel, provide fuel leak detection at the turbine and fuel pump block. Adhere to the following recommendations:

- A. If the fuel temperature is above its flash point, provide vapor LEL detection in accordance with Section 2.4.1.1.
- B. If the fuel temperature is below its flash point, provide FM Approved hydrocarbon leak detector.
- C. Interlock the leak detection system to trip the unit and isolate the fuel supply by means of a fast-acting shutoff valve.
- D. Provide high-liquid-level alarms in fuel spill collection tanks.

2.4.1.3 Provide all liquid and gaseous leak-detection devices with electronic supervision and transmit all alarms to the control room or other constantly attended location.

2.4.1.4 Establish and document the frequency at which detectors are to be recalibrated and tested based on Data Sheet 5-49, *Gas and Vapor Detectors and Analysis Systems*, facility experience, and the detector manufacturer's recommendations.

2.4.1.5 Design and install leak-detection systems so the controls and all components and devices can be readily inspected, calibrated, and tested according to the manufacturer's recommended method and the frequency established per section 2.4.1.4.

2.4.2 Fire Detection for Turbine Compartments

2.4.2.1 Provide FM Approved flame and/or heat detectors arranged in accordance with Data Sheet 5-48, *Automatic Fire Detection*, and Data Sheet 5-40, *Fire Alarm Systems*, to ensure prompt detection of fire in all areas, including below the turbine and any other shielded areas where lube-oil or fuel-oil spills can accumulate.

2.4.2.2 Arrange fire detectors to automatically trip the turbine, shut off the fuel supply, shut off compartment ventilation, close dampers, activate automatic fire protection systems installed within the compartment, and transmit a fire alarm to the control room or other constantly attended location. Arrange these trips to occur sequentially according to the original equipment manufacturer's specifications.

2.4.2.3 Where more than one detector activation is required to trip the turbine, verify that sufficient coverage and redundant detectors are provided to ensure an emergency trip will be initiated while the fire is in the incipient stages of development.

2.4.2.4 Select heat detector settings to avoid spurious alarms in the upper range of expected operating temperatures in the compartment. Select the detector temperature ratings as specified in Data Sheet 5-48, *Automatic Fire Detection*.

2.4.2.5 Provide electronic supervision for fire detection system trouble conditions and annunciate trouble alarms in the control room.

2.4.3 Fire Protection for Turbine, Generator, and Auxiliary Compartments

2.4.3.1 Provide fixed automatic fire protection for the insides of turbine and generator compartments, as well as enclosures for auxiliary equipment such as fuel skids and lubrication-fluid pumping and conditioning equipment, load compartments, exciter compartments, and other enclosures containing oil fire hazards (see Figure 2.4.3.1).

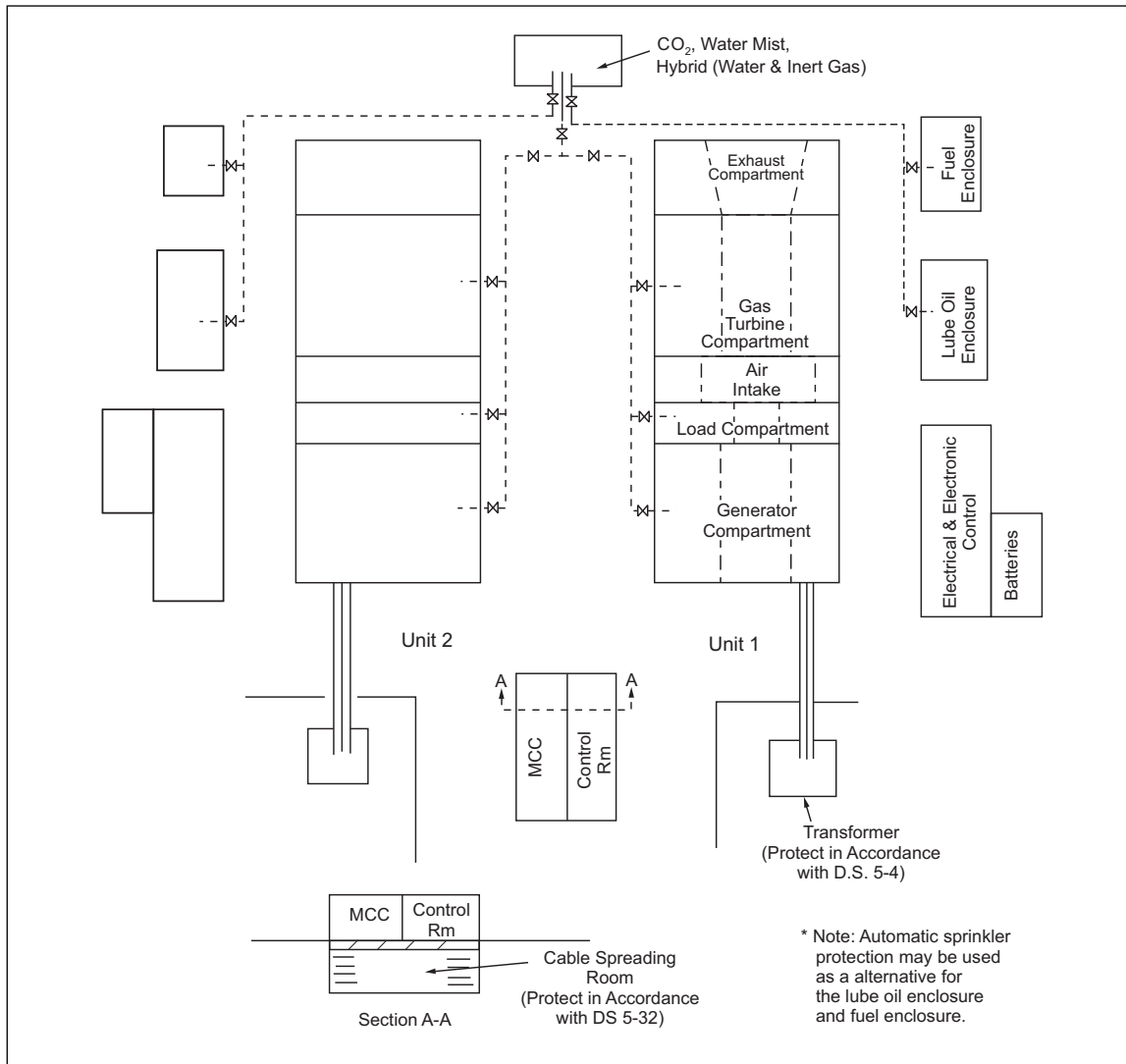

Fig. 2.4.3.1. Enclosed gas turbine protection system

2.4.3.2 Design the extinguishing system to maintain the required agent concentration or provide a discharge duration, as applicable, equal to the greater of:

- A. 20 minutes
- B. The maximum projected time needed to achieve a safe shutdown of the lube-oil system following emergency trip of the turbine, plus 10 minutes. Determine maximum safe shutdown time based on the emergency shutdown procedure (see section 2.6.2).
- C. The maximum projected time to allow exposed hot surfaces to cool below the autoignition temperature of the oil.

2.4.3.3 Activate automatic fire protection systems using the detection system described in Section 2.4.2. Ensure the detection system is compatible with the fire protection system.

2.4.3.4 Provide capability for remote manual activation of the fire protection systems by operators from the control room or other area that will be accessible during a fire emergency.

2.4.3.5 Provide one of the following FM Approved automatic fire protection systems for the insides of turbine and generator compartments, as well as enclosures for auxiliary equipment such as fuel skids and lubrication fluid pumping and conditioning equipment (see Figure 2.4.3.1):

- A. FM Approved inert gas or carbon dioxide (CO₂) system.
- B. Total flooding water mist system FM Approved for the protection of gas turbines or machinery in enclosures, as applicable.
- C. Hybrid (water and inert gas) system FM Approved for the protection of gas turbines or machinery in enclosures, as applicable.
- D. Where fuel, lubrication, and hydraulic oil tanks, pumps, or other equipment not subject to potential water damage are located inside a dedicated room or an enclosure, automatic sprinkler protection designed in accordance with Section 2.4.4 may be provided as an alternative to options A, B, and C above. Do not provide this option for gas turbine enclosures.

2.4.3.5.1 When a carbon dioxide (CO₂) system is provided to protect a turbine compartment, use the following design criteria:

- A. Install the system in accordance with its listing in the *Approval Guide*, the manufacturer's instructions, and Data Sheets 4-0, *Special Protection Systems*, and Data Sheet 4-11, *Carbon Dioxide Extinguishing Systems*.
- B. Provide sufficient agent to achieve an initial CO₂ design concentration of at least 34% by volume within one minute, and maintain a minimum of 30% for the remainder of the concentration hold time determined in Section 2.4.3.2, in either the largest single hazard zone or group of hazard zones protected by the system simultaneously.
- C. Locate and orient CO₂ discharge nozzles to avoid direct impingement by the discharge jet onto the gas turbine.

2.4.3.5.2 When an inert gas system is provided to protect a turbine compartment, use the following design criteria:

- A. Install the system in accordance with its listing in the *Approval Guide*, the manufacturer's instructions, and Data Sheets 4-0, *Special Protection Systems*, and Data Sheet 4-9, *Halocarbon and Inert Gas (Clean Agent) Fire Extinguishing Systems*.
- B. Provide sufficient agent to achieve and maintain a concentration in accordance with the manufacturer's recommendations and Data Sheet 4-9, *Halocarbon and Inert Gas (Clean Agent) Fire Extinguishing Systems*, for the concentration hold time determined in Section 2.4.3.2, in the largest single hazard zone or group of hazard zones protected by the system simultaneously.
- C. Locate and orient discharge nozzles to avoid direct impingement by the discharge jet onto the gas turbine.

2.4.3.5.3 When a water mist or hybrid (water and inert gas) system is provided to protect a turbine compartment, use the following design criteria:

- A. Install the system in accordance with its listing in the *Approval Guide*, the manufacturer's recommendations, and Data Sheets 4-0, *Special Protection Systems*, and Data Sheet 4-2, *Water Mist Systems*, as applicable.
- B. Ensure all system limitations, such as protected volume size, ventilation rate, and opening size, are met.
- C. Hydraulically design the water mist or hybrid system in accordance with the manufacturer's recommendations and the system's listing in the *Approval Guide*.
- D. Design the water mist or hybrid agent supply to provide discharge to the largest single hazard zone or group of hazard zones protected by the system simultaneously, for the time specified in Section 2.4.3.2.
- E. Locate and orient discharge nozzles in accordance with the manufacturer's instruction.

2.4.3.6 Conduct a full discharge acceptance test, in accordance with the system manufacturer's test protocol, to verify the proper operation of the protection system, including all of the following:

- A. Activation of the extinguishing system detectors initiates an automatic emergency trip of the turbine prior to discharge of the agent.
- B. Compartment ventilation shutdown and damper closings occur in the proper sequence prior to discharge of the agent.
- C. An alarm is transmitted to a constantly attended location.
- D. The settings for time delays and any selector valves are correct.
- E. Specified extinguishing concentrations are achieved and maintained for the entire duration of the concentration hold time.
- F. All discharge nozzles flow free and clear, and the discharge from nozzles relative to any obstructions in the compartment is in accordance with the manufacturer's guidelines.

2.4.3.6.1 To accept multiple "identical" units on the same site, conduct a full discharge acceptance test on each unit where fixed protection is needed.

2.4.3.6.2 Do not conduct a "full load" trip test with the turbine at operating temperature.

2.4.3.7 Document the acceptance test procedures and results. Maintain a copy of all documentation on site and ensure it will be available for future reference.

2.4.3.8 Conduct periodic documented visual inspections to verify compartment tightness and ensure the proper concentration of the agent can be achieved and maintained according to design.

2.4.3.9 Conduct periodic documented re-validation of installed fire protection systems through full discharge testing, or simulated discharge plus compartment pressurization testing, at maximum 5-year intervals.

2.4.3.10 Provide a water supply and hose connections for manual firefighting.

2.4.4 Fire Protection for Turbine Buildings

Where the gas turbine and generator is unenclosed, or the design of the compartment is such that burning oil can escape from the enclosure, provide fixed automatic fire protection in the building surrounding the turbine or turbine compartment. Provide protection in areas subject to oil fires that expose the turbine or other important equipment, as determined by an Oil Fire Hazards Assessment (see Section 2.6.4). Ensure water does not directly impinge on hot turbine parts. Refer to Figure 2.4.4 for an example.

Protect warehouses, offices, and other occupancies in accordance with the relevant data sheets.

2.4.4.1 General Automatic Sprinkler Design Considerations

2.4.4.1.1 Provide a reliable, dedicated fire protection water supply of minimum 2-hour duration for the maximum design sprinkler discharge flow rate, as determined in Sections 2.4.4.2 and/or 2.4.4.3, plus simultaneous discharge of any structural steel protection determined to be necessary (refer to Section 2.2.3) and 750 gpm (2840 L/min) for hose streams.

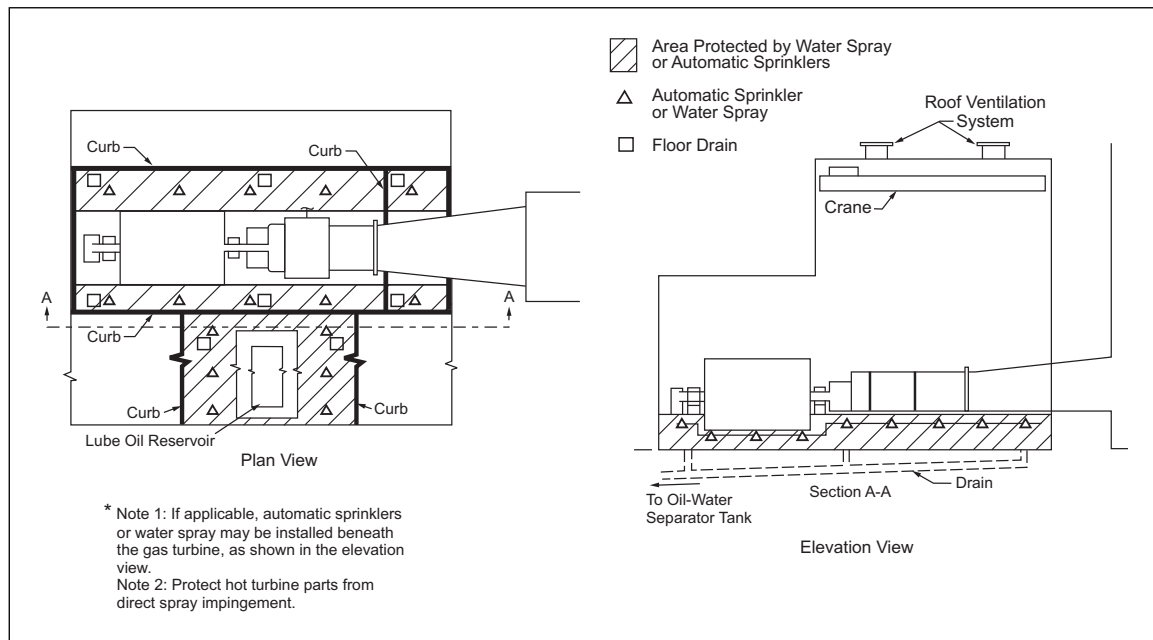

Fig. 2.4.4. Schematic of fire protection system for unenclosed gas turbine installation

2.4.4.1.2 Arrange and install automatic sprinkler systems in accordance with Data Sheet 2-0, *Installation Guidelines for Automatic Sprinklers*. Install automatic water spray systems in accordance with Data Sheet 4-1, *Fixed Water Spray Systems for Fire Protection*. Install foam-water sprinkler systems in accordance with Data Sheet 4-12, *Foam-Water Sprinkler Systems*.

2.4.4.1.3 Use a wet, preaction, or deluge system.

2.4.4.1.4 Provide standard response, high-temperature-rated automatic sprinklers if sprinklers are located under a solid mezzanine or ceiling. The temperature rating of automatic sprinklers located below grated mezzanines is not critical.

2.4.4.1.5 Where the distance between the floor and the sprinklers is less than 15 ft (4.5 m), use a minimum K-factor of 8.0 (115). Where this distance is greater than or equal to 15 ft (4.5 m), use a minimum K-factor of 11.2 (161).

2.4.4.1.6 Arrange sprinklers on a maximum 100 ft² (9 m²) spacing.

2.4.4.1.7 Arrange sprinklers with a maximum on-line spacing of 10 ft (3 m). A variation of ±1 ft (0.3 m) is acceptable on either dimension to avoid obstructions by structural elements.

2.4.4.1.8 Where K 25 EC (363 EC) pendent or upright sprinklers are used, install only at the maximum recommended spacing, as listed in Data Sheet 2-0, *Installation Guidelines for Automatic Sprinklers*. At this spacing, treat as a standard response sprinkler.

2.4.4.1.9 Provide FM Approved fire pumps, controllers, and drivers as applicable. Install the equipment in accordance with the recommendations in Data Sheet 3-7, *Fire Protection Pumps*. If electric motor-driven pumps are used, supply power from a source that will not be interrupted in the event of loss of main power to the facility.

2.4.4.1.10 Arrange fire protection equipment located in areas exposed by earthquakes in accordance with Data Sheet 2-8, *Earthquake Protection for Water-Based Fire Protection Systems*.

2.4.4.1.11 Locate automatic deluge and preaction valves and water spray control valves where they can be manually operated from a safe, easily accessible location during a fire.

2.4.4.1.12 Space detectors for interior deluge systems (either pilot sprinkler, electric, or pneumatic) as follows:

A. Install pilot sprinklers on the same spacing as sprinklers.

B. Install electric or pneumatic devices under smooth ceilings using the spacing requirements listed in the *Approval Guide* for the particular model, or as recommended in data sheets that cover the specific occupancy.

2.4.4.1.13 Space detectors for preaction systems (pilot sprinkler, electric, or pneumatic) as follows:

A. Install electric or pneumatic detectors at a spacing of one-half the listed linear detector spacing, or the full sprinkler spacing, whichever is greater (e.g., if a detector is FM Approved for 30 ft by 30 ft [9.1 m by 9.1 m] and allowable sprinkler spacing is 100 ft² [9 m²], then maximum allowable linear detector spacing is 15 ft by 15 ft [4.6 m by 4.6 m]). For design purposes, treat preaction systems with this detector spacing the same as wet systems.

1. If a preaction system has a detector spacing greater than the above spacing, consider it a deluge system for design purposes. Refer to the *Approval Guide* for the maximum allowable spacing.

B. Install pilot sprinklers on the same spacing as the sprinklers. For design purposes, treat preaction sprinkler systems that use pilot sprinklers the same as dry systems, regardless of detector spacing.

2.4.4.1.14 Transmit fire alarm, water flow alarms, and pump supervisory signals to an alarm panel in the control room.

2.4.4.1.15 Provide portable extinguishing equipment as follows:

A. Standpipes in basement, ground floor, and operating floor areas so all areas can be reached by at least one hose stream.

B. Wheeled dry-chemical and carbon dioxide extinguishers on the operating floor for small fires at bearings.

2.4.4.2 Sprinkler Protection for Pool Fires

2.4.4.2.1 Provide the following sprinkler design over all areas to which burning oil can flow, such as containment areas surrounding the turbine or turbine compartment, around fuel and lube-oil skids, and areas outside of protected compartments if exposed by oil releases.

2.4.4.2.2 Install automatic sprinkler protection at the roof (Figure 2.4.4.2.2(A)) or locally over the fire hazard (Figure 2.4.4.2.2(B)). Based on the height (H in Figures 2.4.4.2.2(A) and (B)) of the sprinklers above the pool fire hazard, provide the sprinkler density specified in Table 1). Extend the protection at least 20 ft (6 m) in all directions beyond the pool fire hazard.

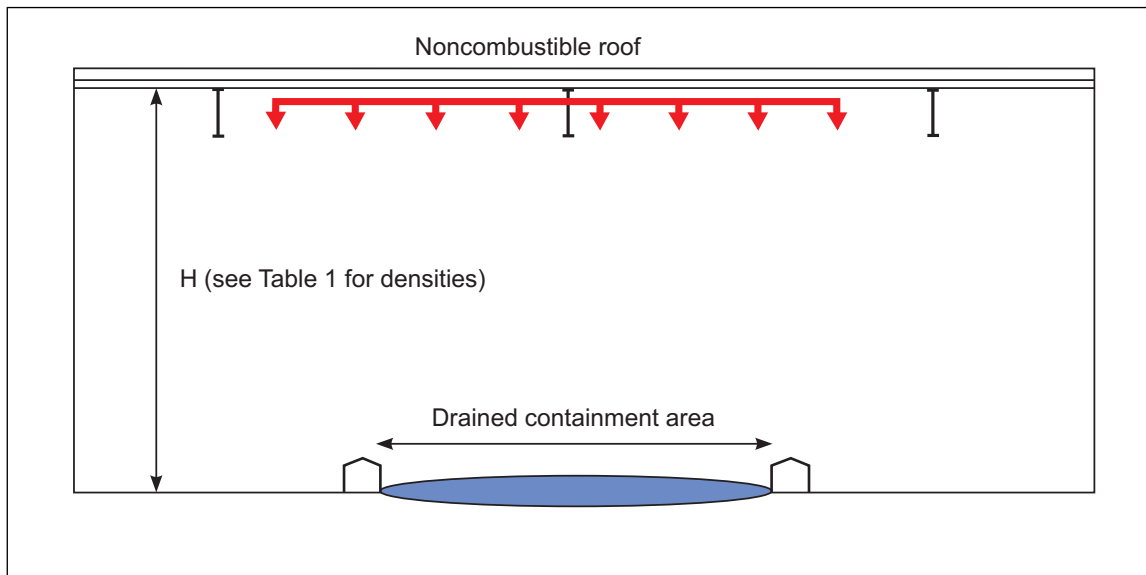

Fig. 2.4.4.2.2(A). Roof level sprinkler option

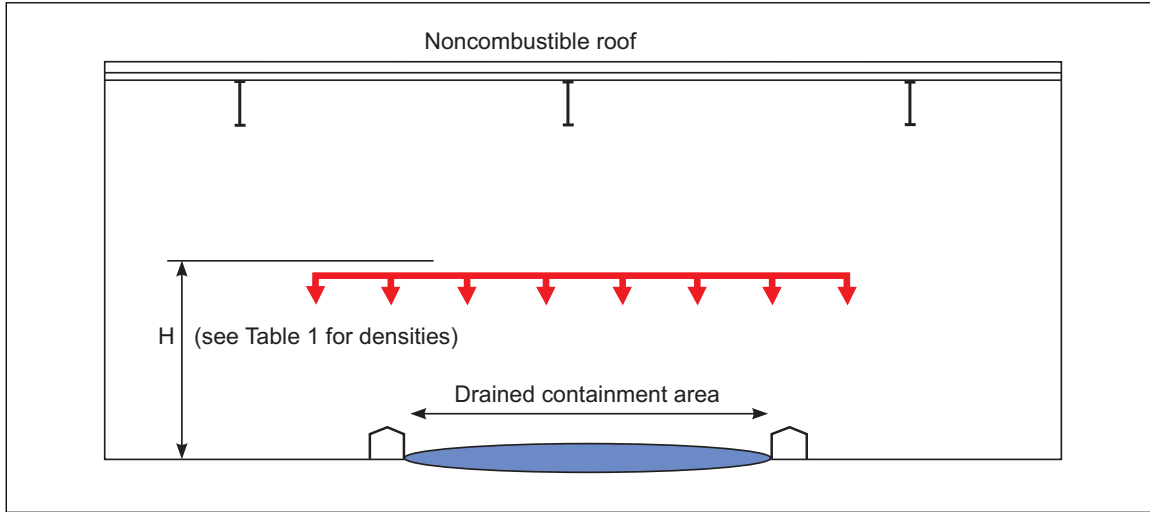

Fig. 2.4.4.2.2(B). Local sprinkler option

Table 1. Sprinkler Densities for Roof-Level and Local Protection Options

Height (H) of Sprinklers Above Pool ¹ ft (m)	Water Density gpm/ft ² (mm/min)
H = 15 (4.6)	0.3 (12)
15 (4.6) < H ≤ 30 (9.2)	0.4 (16)
30 (9.1) < H ≤ 40 (12.0)	0.7 (29)
40 (12.0) < H ≤ 45 (13.8)	0.8 (33)
45 (13.8) < H ≤ 60 (18.5)	1.6 (64)

¹ For "H" see Figures 2.4.4.2.2(A) and (B).

2.4.4.2.3 Design roof-level sprinklers for a demand area of 5,000 ft² (465 m²). Design local sprinklers for a demand area of 5000 ft² (465 m²) or the limits of the containment, whichever is less.

2.4.4.2.4 Where foam-water sprinklers or compressed air foam (CAF) are used, use the following design criteria:

- A. Install the system in accordance with the manufacturer's recommendations, the FM Approval listing, and Data Sheet 4-12, *Foam-Water Sprinkler Systems*.
- B. Where a foam-water sprinkler system is installed, hydraulically design the system in accordance with Table 1 of this data sheet or the FM Approval listing density, whichever is larger, over the full demand area.
- C. Where a CAF system is installed, design the system in accordance with the manufacturer's recommendations and its listing in the *Approval Guide*, and design the sprinkler system in accordance with the recommended sprinkler density in this data sheet.
- D. Design the foam concentrate supply and air supply, if applicable, to provide the full sprinkler discharge (use actual discharge based on water supply) plus any hose streams also arranged to provide foam discharge for the greater of:
 1. 20 minutes.
 2. The maximum projected time needed to achieve a safe shutdown of the lube-oil system following emergency trip of the turbine, plus 10 minutes. Determine maximum safe shutdown time based on the emergency shutdown procedure (see Section 2.6.2).
- E. Include an exterior hose stream allowance of 750 gpm (2,840 L/min).
- F. Provide containment as recommended in this data sheet.

2.4.4.3 Sprinkler Protection for Oil Spray Fires

Provide one of the following protection methods over oil pumps and conditioning equipment where pressurized releases could result in spray fires that expose the turbine building roof, equipment mezzanines, building support columns, gas turbines, or other critical targets:

- A. Provide a room or enclosure around the equipment and spray source in accordance with Section 2.2.5.2. Protect the interior of the enclosure in accordance with Section 2.4.3.
- B. Provide a combination of barriers and sprinklers, designed as follows:
 1. Install a heavy gauge metal (e.g., 12 gauge [2 mm]) spray hood or barrier above the spray fire source. Provide additional barriers where sprays can expose important equipment (see item 1 in Figure 2.4.4.2.2(A)). Support the barrier on the unexposed side.
 2. Provide a wet or deluge sprinkler system under the barrier on a maximum 10 x 10 ft (3 x 3 m) spacing. Do not support the sprinkler piping from the hood.
 3. Use a K-factor of 8.0 (115), and design the sprinklers to provide a minimum end pressure of 50 psig (3.4 barg).
 4. Extend the protection at least 5 ft (1.5 m) beyond each spray source.
- C. Provide closely spaced sprinklers above the spray source, designed as follows:
 1. Install a deluge sprinkler system over each leak point.
 2. Install pendent sprinklers with a K-factor of 8.0 (115), and provide a minimum end pressure of 50 psig (3.4 barg).
 3. Locate sprinklers with approximately 6 ft (1.8 m) vertical clearance above the potential oil spray source.
 4. Provide a minimum of nine sprinklers on 5 x 5 ft (1.5 x 1.5 m) spacing. Extend the protection at least 5 ft (1.5 m) beyond each spray source.
 5. Activate deluge systems automatically using either an FM Approved flame detection system or FM Approved line-type heat detection, with the line-type detection installed around sprinkler piping to ensure a spray fire will activate the system.
- D. Use FM Approved spray fire shields on flanges of piping containing pressurized mineral oil or industrial fluids that are not FM Approved. The use of an FM Approved spray fire shield does not eliminate the need for fire protection, but reduces the fire hazard from a spray fire to a localized pool and spill fire that can be protected according to Section 2.4.4.2.

2.4.5 Water Mist Systems for Oil Fire Hazards in Unenclosed Areas

2.4.5.1 An FM Approved local application water mist system is acceptable as an alternative to local application water spray systems or sprinkler systems over specific oil fire hazard areas, including spray fire, pool fire, and combination spray/pool fire hazards as defined by the oil fire hazard assessment. Local application water mist systems are not applicable to 3D spill fire hazard scenarios.

2.4.5.2 Install the local-application water mist system in accordance with Data Sheet 4-2, *Water Mist Systems*, and the manufacturer's FM Approved Design, Installation, Operation, and Maintenance (DIOM) manual.

2.4.5.2.1 Arrange the water mist nozzles to surround the expected oil pool fire hazard footprint or spray fire source in accordance with the manufacturer's FM Approved layout. Figure 2.4.5.2.1 shows a typical layout.

2.4.5.3 Use water mist systems FM Approved for the "Combination 2D Ignitable Liquid Pool Fire & Spray Fire Protection" application type from the Local Application Protection category. It is expected that areas with potential spray fires will also have pool fire potential. Water mist systems need to be laid out to address both hazards.

2.4.5.3.1 Surround the oil containment area with water mist nozzles in accordance with the manufacturer's FM Approved DIOM manual.

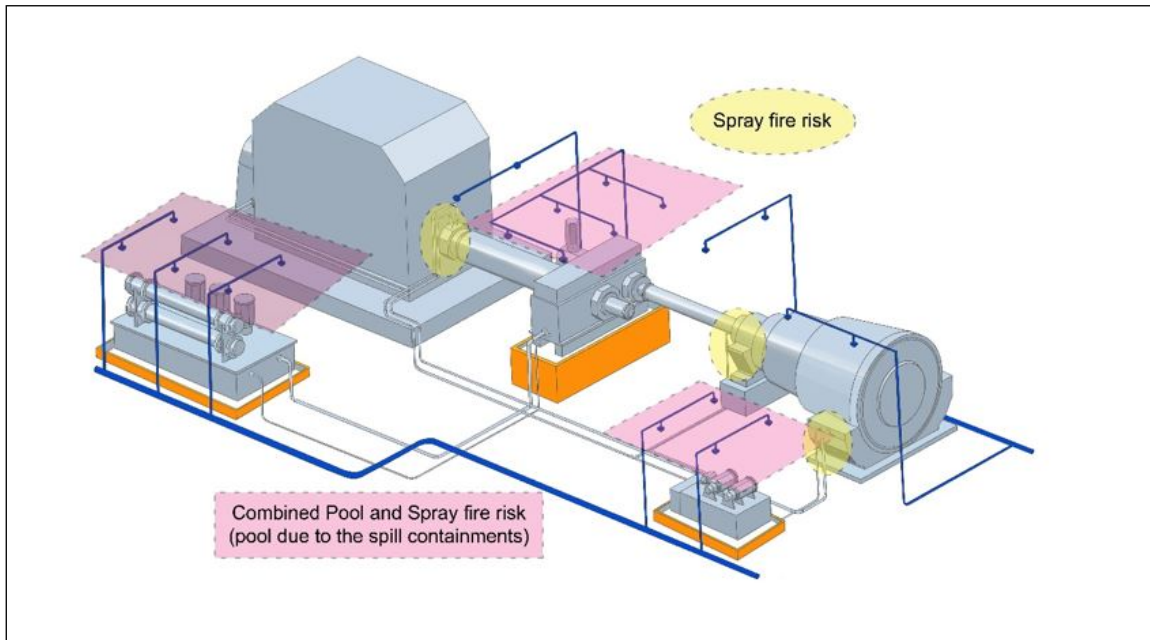

Fig. 2.4.5.2.1. Typical layout of water mist system for local application over oil fire hazards. [NOTE: Shaded areas are not solid barriers, but areas of operation.]

2.4.5.4 It is acceptable to use a water mist system FM Approved for “Spray Fire - Point Protection” where there is a spray fire hazard as long as the system is supplemented by water mist protection to protect the pool fire hazard.

2.4.5.4.1 Direct water mist nozzles at the spray fire release point in accordance with the manufacturer’s FM Approved DIOM manual.

2.4.5.5 It is acceptable to use a water mist system FM Approved for “2D Ignitable Liquids Channel Protection” for drainage channels provided it covers the entire length of the channel.

2.4.5.5.1 If oil is directed through drainage channels to a secondary containment area, surround the release and containment areas with water mist nozzles in accordance with the manufacturer’s FM Approved DIOM manual.

2.4.5.6 Provide drainage and containment in accordance with 2.2.4. Applications in which the oil flow path is not controlled, such as flow below the level of the oil release point or where there are numerous leak points (i.e., flanged piping connections spread out in a large volume), are not suitable to being protected by these systems.

2.4.5.7 Provide a water supply capable of supplying the full design flow of the water mist system for the duration of the oil release event, but not less than 1 hour.

2.4.5.8 Provide a water supply capable of supplying a 500 gpm (1,900 L/min) hose stream allowance for the duration of the oil release event but not less than 1 hour. It is acceptable to source the hose stream allowance from a water supply separate from the water mist system’s.

2.4.5.9 Provide a fire detection system (i.e., heat detector, flame detector, or video detector) arranged to ensure prompt detection of a fire and installed in accordance with Data Sheet 5-48, *Automatic Fire Detection*, and in accordance with the applicable Approval listing.

2.4.5.9.1 For ceiling heights up to 60 ft (18 m), install ordinary temperature spot or linear heat detectors in accordance with the following:

A. Space heat detectors located below solid barriers or ceilings up to 30 ft (9 m) above the fire hazard in accordance with the manufacturer’s FM Approved spacing.

B. Space heat detectors located below solid barriers or ceilings between 30 ft (9 m) and 60 ft (18 m) above the fire hazard at not more than 10 ft x 10 ft spacing (3 m x 3 m).

2.4.5.9.2 For ceiling heights greater than 60 ft (18 m) or where the ceiling is obstructed by piping or equipment, provide local area heat detection or flame/video detectors in accordance with the following:

- A. Provide intermediate heat detector(s) within 10 ft (3 m) above the fire hazard. Place the detectors near potential leak points. Provide at least two detectors near each potential leak point with a linear horizontal spacing between detectors of no more than 4 ft (1.2 m).
- B. Locate flame or video detectors in positions that provide a clear line of sight to the fire hazard. Ensure flame or video detectors are FM Approved for use with the fuels expected to be involved in the fire.

2.4.6 Combustible Roof Protection

Provide one of the following protection methods for buildings with combustible roof construction, including Class 2 steel deck:

- A. Replace the combustible roof with a noncombustible roof.
- B. Install automatic sprinkler protection at roof level. Provide water demand for ceiling protection in accordance with the criteria in Table 2.

Table 2. Ceiling Sprinkler Design Criteria for Turbine Buildings with Combustible Roof Construction

Type of Sprinkler System	Sprinkler Temperature Rating	Density gpm/ft ² (mm/min)	Area of Demand ft ² (m ²)
Wet	High	0.2 (8)	5000 (465)
Dry			8000 (740)
Hose stream demand: 750 gpm (2840 L/min). Duration: 60 min (water supply duration may need to be increased when conditions exist that could delay manual firefighting efforts.)			

2.4.7 Relay and Cable Spreading Rooms and Transformers

- 2.4.7.1 Protect cable rooms and cable trays in accordance with DS 5-31, *Cables and Bus Bars*.
- 2.4.7.2 Protect transformers in accordance with Data Sheet 5-4, *Transformers*.

2.4.8 Control Rooms and Distributed Control System (DCS) Rooms

- 2.4.8.1 Provide detection and automatic sprinkler protection in control rooms and DCS rooms according to Data Sheet 5-32, *Data Centers and Related Facilities*.
- 2.4.8.2 Protect subfloors in accordance with the recommendations in Data Sheet 5-32, *Electronic Data Processing Systems*.

2.5 Equipment and Processes

2.5.1 Fuel Protective Systems

Provide gas turbines with alarms and trips in accordance with Data Sheet 13-17, *Gas Turbines*.

2.5.2 Fuel Supply and Proof-of-Flame

2.5.2.1 Gaseous Fuels

- 2.5.2.1.1 Provide two fail-closed, automatic shutoff valves in series in the fuel supply line, with proof of closure. Provide an automatic vent valve (with position indication in the control room) between the two valves (double block and vent as shown in Figure 2.5.2.1.1). Additionally, provide a pressure or flow transmitter downstream of the fuel gas control valve to monitor the proper flow of fuel through the control valve.
- 2.5.2.1.2 For a unit to qualify for gas turbine purge credit, provide three fail-closed, automatic shutoff valves in series in the fuel supply line, with proof of closure (with position indication in the control room). Provide automatic vent valves between these valves (triple block and double vent). Two acceptable configurations are shown in Figures 2.5.2.1.2(A) and (B).

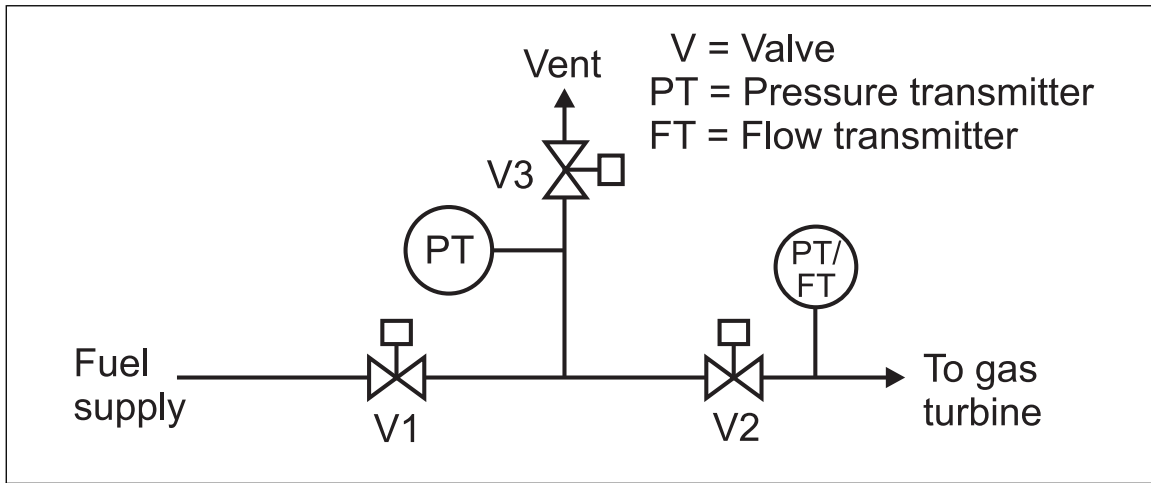

Fig. 2.5.2.1.1. Typical gaseous fuel system (double block and vent)

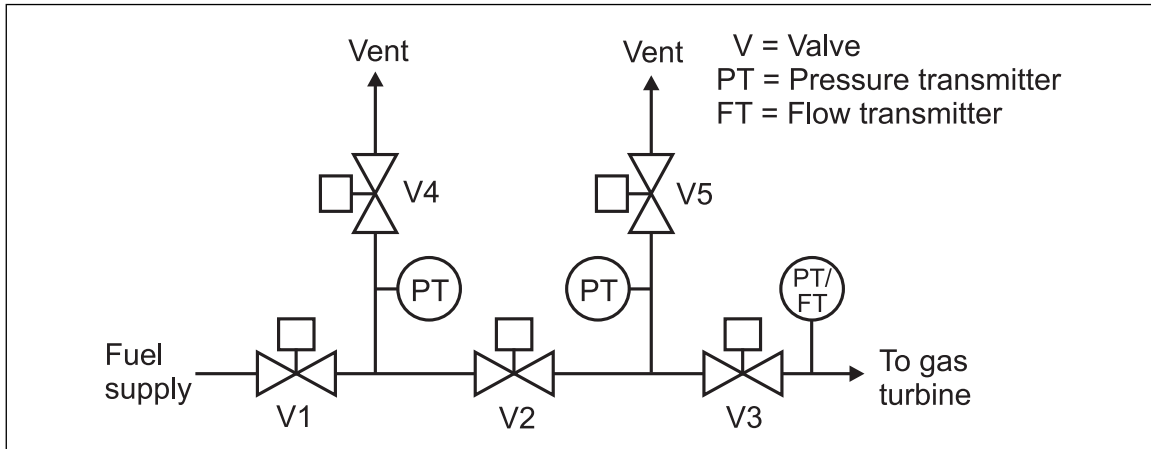

Fig. 2.5.2.1.2(A). Gaseous fuels (triple block and double vent)

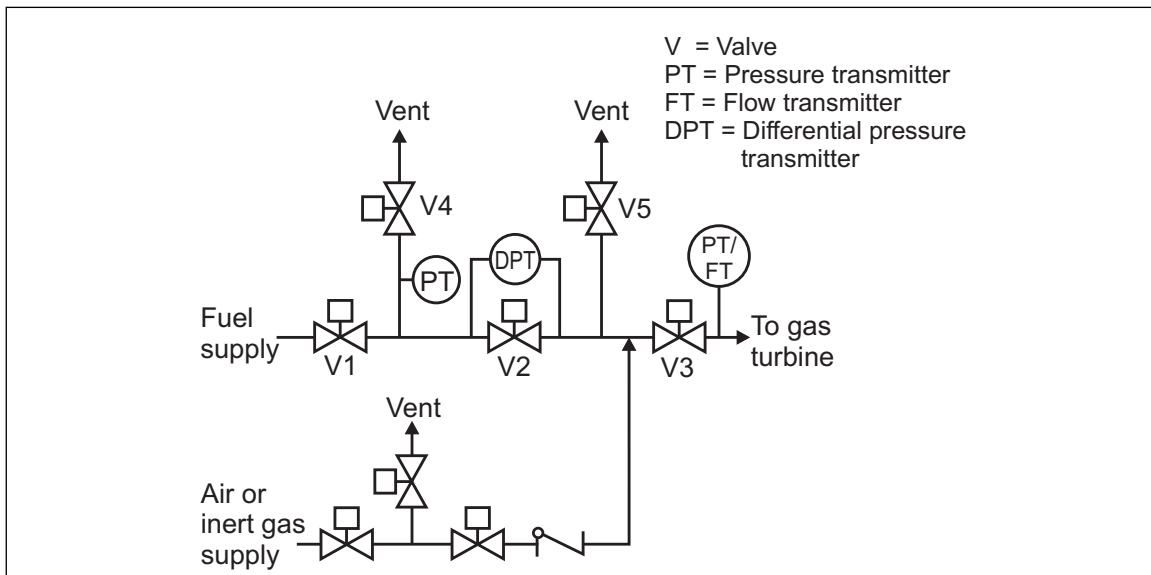

Fig. 2.5.2.1.2(B). Gaseous fuels (triple block, double vent, and pressurized pipe section)

2.5.2.1.3 Use shutoff valves that meet the gas turbine original equipment manufacturer's (OEM's) requirements for closing time and leakage.

2.5.2.1.4 Locate an automatic shutoff valve in a safe location outside the gas turbine enclosure to automatically isolate the fuel supply in case of a dangerous condition.

2.5.2.2 Fuel Gas System Leakage into Balance-of-Plant Equipment

2.5.2.2.1 Provide safeguards that prevent fuel gas from entering balance-of-plant equipment. Fuel gas leakage into balance-of-plant equipment during gas turbine operation or unit shutdown can lead to an explosion with the potential for severe equipment damage.

2.5.2.2.2 Where fuel gas is preheated using steam or feedwater from the balance-of-plant (e.g., in combined cycle plants), provide a method to detect fuel gas in the water or condensate line, or water in the fuel line during operation, as applicable. The specific type of leak detection will depend on the design of the heating system and system parameters such as fuel and water pressure.

2.5.2.2.3 Develop a shutdown procedure to be used to prevent gas migration through the balance of plant in the event a leak is detected prior to shutting the plant down for maintenance. If leak detection is not installed per Section 2.5.2.2.2, follow this shutdown procedure for all maintenance shutdowns (i.e., assume a leak is present whenever a shutdown occurs for the purposes of maintenance activities).

2.5.2.2.4 Prior to performing maintenance on a component(s) that may have had fuel gas collect in it due to leakage, test the atmosphere inside the component(s) for the presence of fuel gas. Use an FM Approved flammable vapor indicator to determine if flammable vapors are present, and purge the equipment of vapors before repairs are made. Route displaced flammable vapors to a safe location. Refer to Data Sheet 7-59, *Inerting and Purging Vessels and Equipment*, for additional information.

2.5.2.3 Liquid Fuels

2.5.2.3.1 Provide two fail-closed, automatic shutoff valves in series in each fuel supply line, with proof of closure. Provide a means to prevent or relieve excess pressure between the two stop valves (e.g., double block and drain as shown in Figure 2.5.2.3.1).

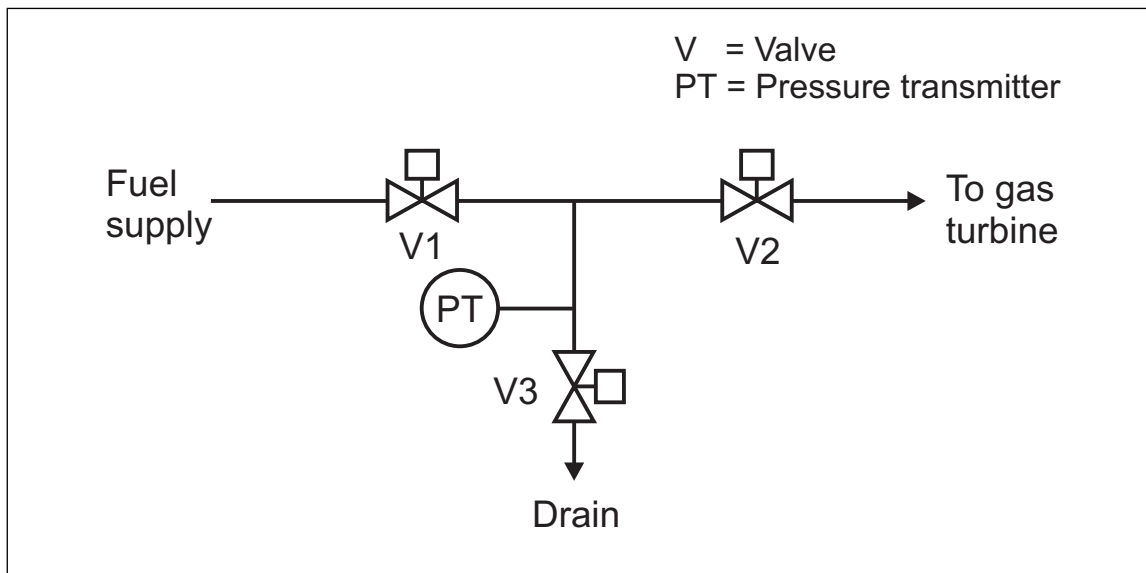

Fig. 2.5.2.3.1. Typical liquid fuel system (double block and drain)

2.5.2.3.2 Use shutoff valves that meet the gas turbine OEM's requirements for closing time and leakage.

2.5.2.3.3 Locate an automatic shutoff valve outside the gas turbine enclosure to automatically isolate the fuel supply in case of a dangerous condition.

2.5.2.3.4 Install automatic drains (false start drains) in the lower combustor casings and/or exhaust casing of the gas turbine.

2.5.2.4 Proof-of-Flame

2.5.2.4.1 Provide a flame monitoring system interlocked to close the fuel shutoff valves and trip the gas turbine in the event of a failure-to-ignite or flameout during operation.

2.6 Operation and Maintenance

Refer to Data Sheet 9-0, *Maintenance and Inspection*, for general recommendations regarding the establishing of maintenance and inspection programs for facilities equipment and systems.

2.6.1. Fire Prevention

2.6.1.1 Identify operation and maintenance activities where errors could result in the accidental release of oil, such as on-line maintenance work on lubrication-oil and hydraulic-oil systems. Include fire prevention warnings and precautions in the procedures for these activities.

2.6.1.2 Ensure equipment and devices that represent potential fuel or lubrication/hydraulic oil-release sources are regularly maintained, inspected, and tested.

2.6.2 Emergency Shutdown Procedures

2.6.2.1 Provide a system that will allow for an emergency trip of the turbine and for lubrication-oil systems to be shut down promptly and safely in emergency situations.

2.6.2.2 Ensure equipment needed for emergency shutdown of the turbine, such as emergency turbine trip and controls for the AC and DC lube-oil pumps, is arranged for remote operation from the control room.

2.6.2.3 Label all emergency activation devices to assist operators during emergency response.

2.6.2.4 Develop a documented emergency shutdown procedure to help limit the extent of property damage and downtime in case of fire.

2.6.2.5 Establish a procedure, including shutdown of lubrication oil systems, if shutdown is necessary, for each of the following scenarios:

A. A fire that is controlled by fixed fire protection systems and/or the emergency response team (such as a minor leak or insulation blanket fire). In this case, the unit will be tripped and the fuel will be shut off upon operation of the fire protection system. However, based on an assessment of the fire event, shutdown of lubrication-oil systems may not be necessary.

B. A single point release of oil and subsequent fire that is not controlled by either fixed protection or the emergency response team, resulting in the need to shut down all equipment, including oil systems.

C. Mechanical damage to turbine generator equipment severe enough to stop the rotating element, with a subsequent fire.

2.6.2.6 With the assistance of the turbine manufacturer or a qualified equipment expert, document the proper sequencing and critical actions required to be taken by operators following an emergency trip of the turbine. Ensure onsite personnel having documented authorization to implement the emergency shutdown procedure are available on all shifts.

2.6.3 Spray Fire Shield Inspection and Maintenance

Inspect and maintain all spray hoods, barriers, and spray fire shields as follows:

A. Itemize, tag, and inspect the equipment on a monthly, recorded basis.

B. Establish a supervision program and documentation system to ensure proper replacement of all spray hoods, barriers, and spray fire shields removed for maintenance activities. Use supervision methods similar to or included in the facility's lock-out tag-out program.

C. Provide periodic refresher training for maintenance and operations personnel on the intent and proper maintenance of spray hoods, barriers, and spray fire shields.

2.6.4 Oil Fire Hazards Assessment (OFHA)

An Oil Fire Hazards Assessment (OFHA) is a detailed, fire-focused engineering review of oil systems, potential release and fire scenarios, and the adequacy of the provided safeguards.

2.6.4.1 Conduct a team-based OFHA. Involve key facility personnel in the review and evaluation of the fire protection safeguards.

2.6.4.2 Conduct an OFHA for each lubrication, seal, or hydraulic control system that uses mineral oil or other fluids that are not FM Approved. See Section 3.1.5 for a description of the methodology and procedures for conducting these reviews.

2.6.4.3 Describe and document the following items by means of narrative and schematics:

- A. Oil system arrangement and operating details (pump capacities, pressure, and reservoir size)
- B. Emergency drainage and containment provisions
- C. Fixed fire protection system design criteria
- D. Emergency response plan
 - 1. Emergency shutdown procedure for oil systems
 - 2. Pre-planning with the public fire service

2.6.4.4 Determine oil-release and fire scenarios based on the compiled equipment and building information.

2.6.4.5 Based on the scenarios, evaluate the adequacy of the provided safeguards and set up action items to make improvements where needed.

2.6.5 Fuel Supply

2.6.5.1 During the startup sequence, purge the unit in accordance with applicable procedures for the jurisdiction of installation.

2.6.5.2 For gaseous fuel systems designed according to Figure 9 (double block and vent), perform a leakage test on the two shutoff valves as follows:

- A. During the shutdown sequence, verify the first shutoff valve (V1) meets the OEM's leakage criteria. If leakage exceeds the OEM's criteria, do not restart the unit until the valve is replaced or refurbished.
- B. During the startup sequence, with airflow passing through the gas turbine, verify that the most downstream shutoff valve (V2) meets the OEM's leakage criteria. If leakage exceeds the OEM's criteria, abort the start.

2.6.5.3 Following a gas turbine normal shutdown, purge credit is allowed for the subsequent start provided the gas turbine is fired with gaseous fuel and one of the fuel system configurations described in Section 2.6.5.3.1 or Section 2.6.5.3.2 is incorporated.

2.6.5.3.1 Triple Block and Double Vent Configuration

- A. Provide the following for a gaseous fuel-fired unit to qualify for purge credit using a triple block and double vent configuration (Figure 2.5.2.1.2(A)):
 - 1. During the shutdown sequence, verify the second shutoff valve (V2) meets the OEM's leakage criteria.
 - 2. While the unit is shut down, continuously monitor both vent line valves to ensure they are open, and the three shutoff valves to ensure they are closed. If continuous monitoring is lost or any valve deviates from its assigned position, purge credit is lost and a subsequent start of the gas turbine requires a unit purge of the gas turbine and downstream components prior to light-off.
 - 3. Continuously monitor pressures in the spaces between the shutoff valves to prove these spaces are not pressurized. If continuous monitoring is lost or either pressure indicates leakage, purge credit is lost and a subsequent start of the gas turbine requires a unit purge prior to light-off.
 - 4. During the startup sequence, with airflow passing through the gas turbine, prove the most downstream shutoff valve (V3) meets the OEM's leakage criteria. If leakage exceeds the OEM's criteria, abort the start.

B. With this configuration, the maximum gas turbine purge credit period allowed is eight days (192 hours). If a unit purge is performed during the eight-day period, the purge credit is reinitiated for an eight-day period. Unit purges can be performed as needed to continue to extend the purge credit period provided the conditions in Section 2.6.5.3.1(A) are satisfied.

2.6.5.3.2 Triple Block, Double Vent, and Pressurized Pipe Configuration

A. Provide the following for a gaseous fuel-fired unit to qualify for purge credit using a triple block, double vent, and pressurized pipe configuration (Figure 2.5.2.1.2(B)):

1. During the shutdown sequence, prior to pressurizing the piping between valves V2 and V3, verify the second shutoff valve (V2) meets the OEM's leakage criteria.
2. Introduce air or inert gas to create and maintain a pressurized pipe section between the middle and most downstream shutoff valves (V2 and V3).
3. Continuously monitor fuel gas shutoff and vent valve positions. If continuous monitoring is lost or any valve deviates from its assigned position, purge credit is lost and a subsequent start of the gas turbine requires a unit purge prior to light-off.
4. Continuously monitor pressures in the two double block and vent pipe sections. If the continuous monitoring is lost, or the pressure downstream of the middle shutoff valve falls to within 3 psi (0.2 bar) of the pressure upstream of this valve, purge credit is lost and subsequent start of the gas turbine requires a unit purge.
5. During the startup sequence, with airflow passing through the gas turbine, prove the most downstream shutoff valve (V3) meets the OEM's leakage criteria. If leakage exceeds the OEM's criteria, abort the start.

B. The purge credit period is maintained as long as the conditions in Part A above, Items 2, 3, and 4, are met. The purge credit period is not limited to eight days.

C. Ensure fuel cannot enter the air or inert gas supply line at any time.

2.6.5.4 Inspect the fuel system in accordance with the OEM's recommendations. At a minimum, inspect the fuel system during scheduled dismantle inspections (refer to Data Sheet 13-17, *Gas Turbines*, for additional information). As part of this inspection, test fuel shutoff valves for leak tightness.

2.6.5.5. Test automatic drains in the lower combustor casings and/or exhaust casing of the gas turbine annually to ensure they operate properly.

2.7 Training

2.7.1 Employee Training

2.7.1.1 Provide periodic refresher fire awareness and prevention training to operators and maintenance personnel.

2.7.1.2 Conduct regular training for all personnel designated to perform emergency shutdown functions. For example, the following training methods can be used:

- A. Simulator training
- B. Unannounced drills, where a fire scenario is given to the operators and they are asked to respond according to the emergency shutdown plan. Operators are asked to describe appropriate actions according to the emergency plan without actually taking action such as pushing a button. Flaws may become apparent using this training method that would not show up in a written test.
- C. A written and/or oral exercise in which a problem is described and questions are asked regarding proper actions to take.

2.7.2 Contractor Training

2.7.2.1 Ensure contractors with access to turbine and fuel-handling areas are trained in fire prevention methods, including facility hot work policy and procedures.

2.7.2.2 Train contractors to follow in-plant notification procedures for emergency situations.

2.8 Human Factor

Refer to Data Sheet 10-0, *The Human Factors of Property Conservation*, for general recommendations and guidance.

2.8.1 Supervision of Programs

2.8.1.1 Designate qualified facility personnel with responsibility for implementing the loss prevention programs and activities associated with gas turbines and generators.

2.8.1.2 Provide the designated personnel with appropriate training, resources, and a management reporting procedure.

2.8.2 Supervision of Contractors

2.8.1.1 Establish a policy and programs to supervise outside contractors while at the facility.

2.8.1.2 Refer to Data Sheet 10-4, *Contractor Management*, for guidance on developing an effective program to manage contractors.

2.8.3 Plant Inspections

2.8.3.1 Conduct regular recorded inspections of all oil systems to detect and repair leakage.

2.8.3.2 Periodically inspect all fire protection equipment in accordance with Data Sheet 2-81, *Fire Protection System Inspection, Testing and Maintenance*.

2.8.4 Emergency Response and Pre-Incident Planning

Design the facility's emergency response plan to address potential fire scenarios as established in the Oil Fire Hazards Assessment (see Section 2.6.4). Refer to Data Sheet 10-1, *Pre-Incident Planning*, for general guidelines on establishing and maintaining an emergency response plan.

2.8.4.1 Arrange and prepare documented procedures to expedite safe entry and emergency response to situations such as fires and explosions in turbine areas, including the following:

- A. Manual emergency trip of the turbine
- B. Notification of facility management and the emergency response team (include names and up-to-date contact information)
- C. Organizational responsibility for managing emergency response
- D. Shutting off pump(s) supplying oil to the control-oil system if mineral oil is used
- E. Information on when to shut off AC and DC lube-oil pumps without significant damage to the shaft, as well as guidelines and timing for shutting off AC and DC lube-oil pumps as a last resort in fire situations
- F. A procedure for switching from AC lube-oil pumps to the DC lube-oil pump if this will result in a reduction in pressure and flow rate from a leak while also supplying an adequate amount of oil to bearings to prevent damage
- G. Emergency procedures for driven generators or compressors
- H. A means of venting hydrogen from and purging the generator
- I. Steps needed to isolate electrical equipment in the fire area

2.8.4.2 Provide a method of communication (e.g., cellular phones or radios) for control room operators in the event normal communication methods are interrupted during a fire. Ensure emergency calls will go to the public fire service nearest the facility.

2.8.4.3 Prepare schematics to guide responders and indicate the location, contents, emergency access route, and emergency remote controls for shutting down equipment.

2.8.4.4 Train and authorize designated personnel to be liaisons with the public fire service.

2.8.4.5 Provide the local fire service with sufficient knowledge of turbine fire hazards and response procedures to aid them in conducting firefighting operations. Document this information in the pre-incident plan with the local fire service.

2.8.4.6 Where applicable, account for earthquake perils in the emergency response plan according to Data Sheet 10-1, Pre-Incident Planning.

2.8.5 Audits and Management of Change

2.8.5.1 Conduct periodic self-audits of the loss prevention and property conservation programs related to turbine fires.

2.8.5.2 Establish documented procedures to manage the hazards of changes relating to turbine fire hazards, such as modifications to existing processes, installation of new equipment and processes, and changes in personnel.

2.9 Ignition Source Control

2.9.1 Hot Work

2.9.1.1 Establish a hot work permit and supervision program in accordance with Data Sheet 10-3, *Hot Work Management*.

2.9.1.2 Require contractors to adhere to the rules of the facility's hot work permit and supervision policy.

2.9.2 Other Ignition Sources

2.9.2.1 Insulate and shield hot surfaces above the autoignition temperature of fuel and mineral oil to prevent deposits or sprays from igniting.

2.9.2.2 Where hot surfaces must be kept uninsulated, remove any combustible accumulations on a daily to weekly frequency, depending upon the rate of accumulation.

2.9.3 Inlet Air Filters and Evaporative Coolers

2.9.3.1 Provide strict control of ignition sources where combustible media are present in air inlet filters and evaporative coolers.

2.9.3.2 Restrict entry and access to authorized personnel using a work permit system.

2.9.3.3 Install any temporary wiring that may be necessary during repairs in accordance with Article 305 of the National Electrical Code, NFPA 70, or applicable local electrical codes. (2.5.3 Data Sheet 1.6, *Cooling Towers*)

2.9.3.4 Do not use high-temperature fixtures such as halogen types.

2.9.3.5 Mark the accesses and exterior walls of the filter house and evaporative cooler with prominent warning signs indicating that access, hot work, and smoking are restricted due to fire hazards.

3.0 SUPPORT FOR RECOMMENDATIONS

3.1 General

Despite a relatively high flash point, mineral oil used in turbine lubrication and control systems presents a severe hazard due to the potential for a large quantity of oil to escape and ignite an uncontrolled, high heat-release fire. A mineral oil release and fire inside a turbine building or compartment can create significant exposures to critical equipment, production, and the building itself. Fire scenarios can include a spray fire, a spill fire, a pool fire, or combinations of these events. The most effective means of limiting damage from oil fires is to quickly shut down the affected oil system. Control-oil systems can usually be shut down quickly, but lubricating-oil shutdown while the turbine is running will likely cause additional equipment damage. Fire protection efforts recommended in this data sheet include the following:

- A. A comprehensive program to prevent accidental oil releases.
- B. An effective emergency shutdown procedure.

C. A combination of active and passive protection features that include construction, curbing, emergency drainage, automatic fire protection, structural steel protection, spray hoods, barriers, and spray fire shields.

The key goals of any fire protection scheme are to shut down the fuel supply as quickly as possible, control where the released oil flows, and use automatic sprinkler protection to provide cooling and possible extinguishment of burning pools of oil. This combination of protection elements is used to limit the extent of damage. Turbine buildings contain high values per unit of floor area. Loss of generating capability can result in substantial loss of business income.

3.1.1 Release Sources

Oil could be released at flanges, filters, gauges, threaded joints and fittings, sight glasses, oil coolers, bearings, rubber expansion joints (bellows), and hoses, typically due to equipment failure or human error. The initiating event may be, for example, a mechanical breakdown that severs a lube-oil supply or return line at the bearing connection, releasing a large quantity of oil (Figure 3.1.1), which subsequently ignites. This type of extreme incident is generally assumed to be of relatively low likelihood, but nonetheless is credible and foreseeable based on actual loss history. Oil leakage rates have ranged from 6.5 to 125 gpm (24.6 to 474 L/min). The safeguards recommended in this data sheet are intended to protect against the fire exposures created by the escaping burning oil in this type of release and fire scenario.

Failure of welded pipe is not considered a likely release source.

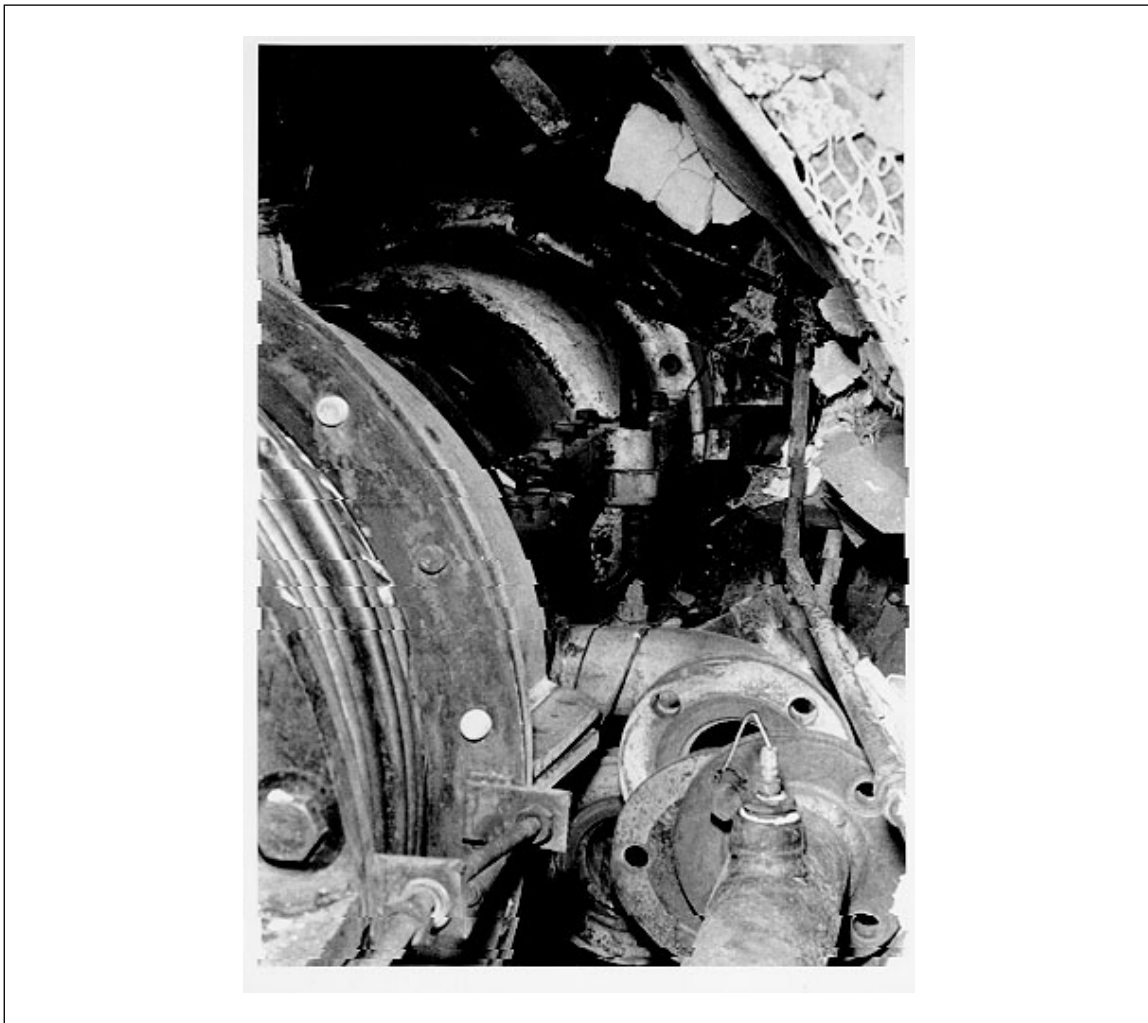

Fig. 3.1.1. Lube-oil release source: broken supply line

3.1.2 Ignition Sources

Following the release of oil, several ignition sources exist that could cause a significant fire within the turbine compartment or building, or in auxiliary compartments. Some common potential ignition sources include:

- A. Electrical equipment
- B. Static charge
- C. Hot surfaces associated with the equipment (e.g., bearings, combustors, etc.)
- D. Smoking
- E. Maintenance operations

The majority of ignition sources are associated with the turbine, due to the presence of high-speed, rotating equipment. However, both ignitable liquid and ignition sources are present in other areas as well, including auxiliary fuel and oil compartments. Additionally, the liquid may be pumped at high pressures and flow rates, resulting in the potential for the release of an atomized spray (see Section 3.1.3). A spray of finely atomized droplets may impact the ignition of an ignitable liquid in comparison to a pool or spill. Therefore, while it is important to consider equipment surface temperatures relative to the auto ignition temperature of an ignitable liquid, the other ignition sources listed above should not be disregarded.

Where important equipment is exposed by an ignitable liquid such as fuel or lube oil and a potential ignition source, it is critical to provide fire protection as recommended in this data sheet. Without this protection, even a small fire could lead to significant equipment damage and business interruption.

3.1.3 Oil Fire Hazards

When mineral oil is released under pressure, the resulting atomized spray or mist of oil droplets can extend up to 40 ft (12 m) from the break. The oil spray can be ignited readily by exhaust ducts, electric heaters, open flames, welding arcs, or other hot objects. The resulting fire is torch-like, with a very high rate of heat release (Figure 3.1.3).

Automatic sprinkler discharge may help limit damage to the building structure and prevent involvement of other combustibles, but the spray fire will not be extinguished and may open an excessive number of sprinklers unless the oil discharge is cut off promptly.

By fitting FM Approved spray fire shields over oil piping flanges, the spray fire hazard at the flange can be reduced to a localized spill and pool fire that can be controlled by local automatic sprinkler protection, curbing, and emergency drainage for the area of the release. FM Approved spray fire shields are subjected to a 45-minute hydrocarbon fire, during which they have demonstrated the ability to maintain their structural integrity and limit the release of oil to within a 5 ft (1.5 m) radius from the centerline of the shield.

3.1.4 Approved Industrial Fluids

Electro-hydraulic control (EHC) systems operate at very high pressures (thousands of psi, hundreds of bar) and therefore present potential severe spray fire hazards when the control system is pressurized by mineral oil or other hydrocarbon-based fluid. Some turbine manufacturers use mineral oil from the main lubrication oil reservoir as the EHC fluid, while others use a separate, smaller reservoir containing EHC fluid that may be hydrocarbon-based.

Mineral oil and other hydrocarbon-based lubricating and hydraulic fluids have relatively high flash points but can be readily ignited by strong ignition sources. Once released and ignited, these fluids will burn with a very high heat release that is typical of all hydrocarbons, regardless of flash point.

Some so-called "fire-resistant fluids" will burn very intensely when released and ignited as a spray or aerosol. FM Approved industrial fluids, which are listed in the *Approval Guide*, are tested to demonstrate a limited heat release rate and inability to stabilize a spray flame, and therefore do not in and of themselves require fire protection measures.



Fig. 3.1.3. Mineral oil spray fire (90 psig [6 barg]) demonstration test performed by FM

3.1.5 Oil Fire Hazards Assessment (OFHA)

Loss experience shows that fires resulting in significant property damage and lost generating capacity have resulted from release and ignition of mineral oil in situations where fire protection was not adequate. Where fire protection was not adequate, emergency shutdown and effective fire response were major factors in limiting damage and downtime.

Effective design for fire prevention and damage mitigation requires a thorough understanding of the specific fire hazards created by the use of mineral oil in the turbine lubricating, electro-hydraulic control, and seal-oil systems of turbines and generators. An OFHA is a site-specific, fire-focused engineering analysis of these oil systems, their hazards, and the provided safeguards. An OFHA can be used during the initial design of new facilities as well as for the evaluation of existing fire protection. The OFHA also can play an important role in enhancing fire protection over the life of the facility through the implementation of human element programs, especially oil-fire awareness training using the fire scenarios and drawings that are prepared as part of the assessment.

Involving facility personnel in a team-based approach to the OFHA will help to further their understanding of the hazards and the critical role operators play in oil-fire protection. Equally important, these personnel can provide detailed knowledge of oil systems, main equipment layouts, and building features that will help develop realistic fire scenarios.

There is no single prescribed format or method for conducting a hazards assessment. The following is an outline of one possible approach to an OFHA, where the end-product of the assessment is a document that

includes a narrative describing the oil system; schematics, drawings, and pictures describing the oil system; design-basis fire scenarios; and safeguards that are or will be in effect.

A. Basic Design Documentation

1. Compile a description of each mineral-oil system, including (a) oil quantity or reservoir capacity, (b) pump flow and pressure, (c) piping diagrams, and (d) piping schematics and drawings.
2. Describe the design details of existing or proposed emergency drainage and containment features for controlling oil releases. Supplement this description with architectural, civil, structural, and equipment arrangement drawings of the facility as needed to support the development of spill scenarios that include the likely flow path(s) of the released oil.
3. Extract design information from these drawings and prepare working schematics to facilitate the analysis and discussion of the fire hazards associated with the oil systems.
4. For existing installations, prepare a set of current photographs of the equipment and oil piping in a "walk-down" format. For both proposed and existing installations, computer-generated isometric views of the power plant in relation to the oil systems also can be prepared to facilitate visualization of the scenarios. The existing design drawings may provide this information.
5. Describe the normal and emergency shutdown procedure for each oil system in a narrative format, including the timing and sequencing of the shutdown. List the designated personnel who can authorize and execute the shutdown. Include a description of the design measures that would allow the operators to remain in the control room to respond during fire emergencies (separate building, room under positive pressure, etc.).
6. Describe the design details for fixed fire protection systems, such as automatic sprinklers, gaseous extinguishing agents, foam, water mist, and hybrid systems.
7. Describe fire protection for high-value, critical equipment and areas (e.g., control rooms, cable spreading and instrumentation rooms, cable trays, switchgear, etc.) that may be directly impacted by an oil fire or exposed to nonthermal damage.

B. Determine Oil-Release Scenarios

1. Using the compiled information and the prepared schematics, conduct a table-top review of each oil system, identifying the potential oil-release sources. Mechanical breakdown and on-line maintenance of oil systems may lead to the release of oil.
2. Consider alternative release points for each mineral oil system.
3. For each release source, obtain the pressure and flow rate and determine the type of fire (e.g., pool fire, spray fire).
4. Loss experience indicates the size of the release is difficult to predict. Estimate the potential release size and resulting fire duration based on the reservoir capacity and inherent limits on oil release (approximately $\frac{2}{3}$ to $\frac{3}{4}$ of tank capacity).
5. Determine the likely flow path(s), starting from the source and ending at the drains, a curbed area within or outside of the turbine compartment, or other low points.
6. Conduct a physical walk-down and revise the release scenario as needed.
7. Document the release scenarios and identify the credible worst cases in terms of size, flow rate, and flow path taken by the released oil.
8. Estimate the release duration based on the emergency shutdown plan and in the event emergency shutdown procedures are not followed (due to unforeseen difficulties that may occur in any fire situation).

C. Determine Oil-Fire Scenarios

1. Assuming ignition will occur, assess the potential fire damage to critical equipment and the building based on the release mode, duration, quantity, and flow path of the oil. Take into account the mitigating effects of fixed fire protection systems, drainage, and containment.
2. Conduct a walk-down of the fire area and revise the fire scenario as needed.

3. Document the fire scenarios and identify worst case scenarios (see Figure 3.1.5 for suggested format).

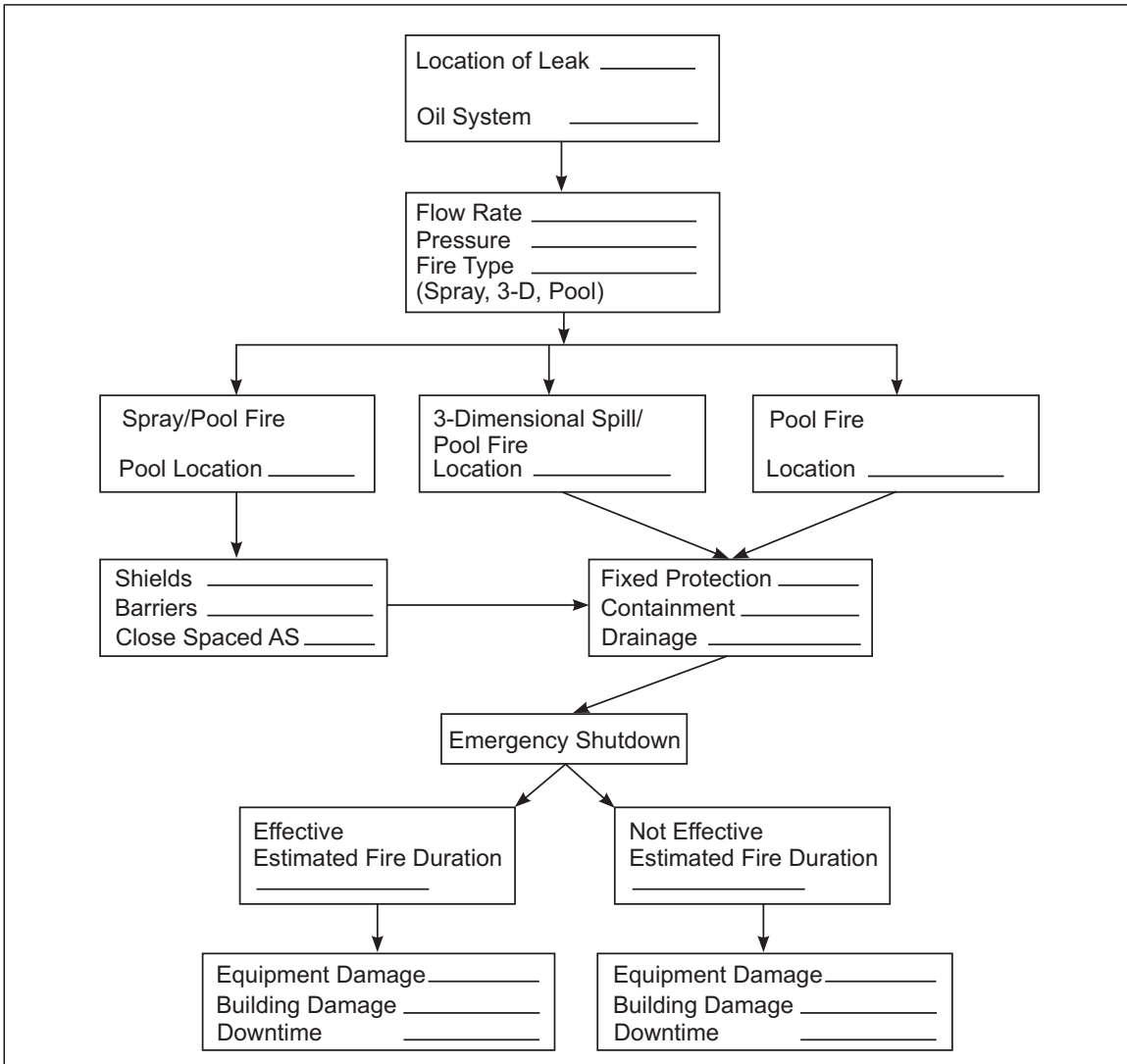

Fig. 3.1.5. Oil-release and fire scenario checklist

D. Evaluate Adequacy of Fire Protection, Including Prevention

1. Assess the impact of the fire scenarios in terms of potential property damage and business interruption for the worst-case scenarios.
2. Determine where it is feasible to prevent or reduce fire damage and downtime through physical protection, such as drainage, containment, spray fire shields, and fire protection.
3. Determine if improvements are needed in emergency shutdown plans and fire awareness/prevention training programs. Ensure the emergency response plan incorporates appropriate measures to limit the size and duration of an oil fire.

E. Implement Action Items

Assign follow-up responsibility for improvements in prevention and mitigation of oil fires.

F. Training and Loss Prevention Programs

1. Use the images, schematics, and findings of the OFHA to train operators and maintenance personnel in the hazards of oil fires, as well as emergency response procedures.
2. Ensure oil-fire awareness training is conducted on an ongoing basis for all employees and reflects the hazard as determined by the OFHA.
3. Incorporate findings into operating and maintenance procedures where appropriate to reduce errors that could result in oil release.

G. Audits and Management of Change

Implement a management of change process for oil systems and safeguards to be certain no changes occur that could increase the severity or consequence of an oil fire.

3.2 Location and Construction Safeguards

Location and construction safeguards are key to limiting the extent of damage in the event of a turbine fire. These measures provide a passive layer of protection that must typically be planned in the early design phase of a new installation.

3.2.1 Site Layout and Equipment Arrangements

Site layout and equipment arrangements can protect against oil-fire exposures by virtue of hazard isolation features such as separation distance between adjacent units, and between the turbines and their lubrication-oil equipment. For new, large gas turbine facilities, isolation of the lubrication-oil storage, pumping, and conditioning equipment in a separate fire area from the gas turbine is a key design goal that can significantly reduce overall fire risk.

3.2.2 Structural Steel Protection

Steel columns supporting the building or critical equipment mezzanines can be protected by:

- A. FM Approved fire-rated cementitious (spray-on or trowel-applied) coatings rated for hydrocarbon fires, or
- B. Directional water spray.

Fire-resistant coatings can be applied with a spray gun by a contractor licensed by the coating manufacturer. There normally are two coatings applied: a prime coat and an ablative intumescent coating.

When water spray is used for the protection of steel columns, it is important to have a continuous film of water over the protected area. Fusible link actuated sprinklers may be used if equipped with shields to prevent cold soldering.

3.2.3 Spill Containment and Emergency Drainage

The key objectives of spill containment and emergency drainage are to:

- A. Limit oil pool size.
- B. Shorten the path and time for oil to flow to the drains.
- C. Confine oil and drain it to areas protected by water spray or sprinklers.
- D. Effectively direct the combined oil and fire water discharge from the turbine building to an acceptable location.

Properly engineered containment and emergency drainage is vital to limit the extent of damage that could result from oil fires inside turbine buildings.

3.3 Automatic Fire Protection

In addition to construction and location safeguards, automatic fire protection is necessary to help control the extent of the fire damage.

3.3.1. Fuel Leak Detection

The hazard is a potentially significant fuel release from a broken or leaking pipe connection at high delivery pressures, followed by ignition as a burning liquid fire or possibly the deflagration of a vapor cloud inside a compartment or turbine building.

3.3.1.1 Fuel Gas Leaks

The overall goal of detection is to:

- A. Reliably and promptly identify leaks.
- B. Initiate shutdown of the turbine and fuel supply prior to ignition of a fire or a flammable cloud capable of deflagration.

A reliable gas detection system must also be designed to avoid spurious trips due to detector malfunctions, software errors, and operational upsets of a non-emergency nature. Settings and locations of detectors will be dependent on the specifics of the compartment and the turbine. Set points must also be selected taking into account the high ventilation rates present in many compartments during turbine operation, which may mask a relatively large leak if the alarm and trip levels are set at more than 25% of LEL.

3.3.1.2 Liquid Fuel Leaks

Fires and deflagrations have been associated with leaks of liquid fuel inside turbine enclosures. Typically, these events occur during commissioning or fuel change-over.

3.3.2 Special Extinguishing Systems

Special extinguishing systems are typically installed to provide automatic fire protection for turbine compartments. Where large, high-value units are being protected, reliability of the fire protection system is critical. There are many potential causes of special extinguishing system failures or ineffectiveness, including inadequate design and/or installation; out-of-service systems (impaired protection); loss of power; manual actuation only (inaccessible or delayed actuation); fire spread outside the protected area/equipment; and inadequate inspection, testing, and maintenance.

3.3.2.1 Acceptance Test Protocol

Two key acceptance criteria for a special extinguishing system are:

- A. Installing an FM Approved system, and
- B. Conducting a successful full discharge test with fully documented test protocol and results demonstrating the system meets the appropriate design criteria.

Special protection systems are more complex than conventional sprinkler systems and consequently subject to more electrical, mechanical, and software failure modes. Therefore, a full discharge concentration test simulating activation under actual turbine operating conditions is necessary to ensure these systems will perform as intended.

Where multiple units of identical design are present on a site, conduct a full discharge test is preferred for each unit, for the following reasons:

- A. Problems might not be identified without a full discharge test.
- B. Even "identical units" will frequently have "as-built" variations that could affect the performance of the special extinguishing system.

To ensure reliability, the acceptance test must be carefully designed to prove and verify the functionality, timing, and sequencing of all critical devices and software needed to achieve and maintain the design concentration following a turbine trip under actual operating conditions. The directions of the turbine manufacturer must be followed so discharge testing will simulate operating conditions as closely as possible without increased risk to the unit. Prior to testing, all activities, critical devices, and acceptance criteria are documented in a check-list format that will help ensure the test is conducted properly and the results are preserved for future reference.

3.3.2.2 Inspection, Testing, and Record Keeping

Subsequent to a successful acceptance test, the reliability of special protection equipment is dependent on implementation of a rigorous, ongoing inspection and testing program that remains in effect over the life of the equipment (refer to Data Sheet 4-0, *Special Protection Systems*). An onsite central file and record-keeping system is an essential part of the protection maintenance and inspection program, but, surprisingly, many locations have few or no records of the acceptance test results.

3.3.2.3 Field Example

Many field examples are available demonstrating the necessity of testing all functions and conducting a full discharge test on all new special protection systems. In one case, a CO₂ system with a central storage tank was installed to protect four 50 MW turbine compartments. The CO₂ system was arranged with a selector valve so the supply would discharge into the enclosure where the fire was detected. A full discharge acceptance test was conducted on Unit 4 by activating a heat detector, which was supposed to shut off the fuel supply and the exhaust system. When the detector was activated, the CO₂ system discharged into the Unit 4 enclosure, but the interlocks for fuel supply and exhaust air were improperly wired and caused a shutdown of Unit 3. Unit 4 fuel supply and exhaust continued to operate and the discharged CO₂ was exhausted from the enclosure. After the system was properly aligned, another test was conducted and it was found that CO₂ concentrations could not be maintained for the design duration due to inadequate sealing of the compartment walls and penetrations.

3.3.2.4 Determination of Extinguishing Period

The time during which an extinguishing system will continue to discharge or maintain a specific gas concentration inside the turbine compartment is a key design parameter for special extinguishing systems due to the potential for reignition when the system has stopped operating or the agent concentration has been diluted below effective levels. The extinguishing period duration is specific to the turbine design, varying as needed to allow for both of the following:

- A. Time to shut off the pumps supplying oil to the fire area
- B. Time to allow exposed hot surfaces to cool below the autoignition temperature of the oil

The duration of oil flow in an actual fire is an uncertain parameter that can only be estimated using the design-basis fire scenarios and the emergency shutdown procedure for the unit. Setting the extinguishing period equal to the maximum expected duration of oil flow (per the emergency shutdown procedure), plus at least 10 minutes as a safety factor, will help ensure a sufficient supply of extinguishing agent for the initial phase of the fire to give manual responders time to apply hose streams to control any subsequent reignition. If time for cooling metal surfaces below the autoignition temperature of the fluid is not known and not available from the turbine manufacturer, surface temperatures can be measured by thermocouples and infrared scanning devices.

3.3.3 Automatic Sprinkler Systems

3.3.3.1 Large-scale testing of oil fires indicates increasing density is needed to achieve control of pool fires as the clearance of the sprinklers above the pool increases.

3.3.3.2 Testing also shows that oil-spray and three-dimensional spill fires cannot be extinguished by sprinkler discharge. For these fires, an emergency shutdown plan and proper construction features are key to limiting the extent of damage.

3.4 Emergency Shutdown Procedure

The objective of the emergency shutdown procedure is to promptly trip the turbine generator, shut off the fuel supply, and in some cases shut off the oil supply to the unit. The length of time of lube-oil pump operation is a major factor in the amount of damage to the turbine generator and how long a unit is out of service. For a large modern gas turbine, thousands of gallons of mineral oil are present in the lubrication system, and circulating at very high flow rates.

The length of time lube-oil pumps run will be an operator decision. Further damage has been limited where operators were able to rapidly shut off lubricating oil after they recognized the gas turbine was at a standstill due to severe equipment damage. Where a mechanical event has stopped turbine rotation, continued oil

flow is not expected to reduce internal equipment damage, and shutdown of lube-oil pumps is recommended. A fire chief may order lube-oil pumps shut off to prevent severe structural damage or reduce life safety concerns.

Operators need emergency procedures that will allow proper action in the event a rapid shutdown is necessary. Consult the turbine manufacturer to determine the speed below which oil pumps can be shut off without causing significant damage to the equipment. In the interim, the heat release rate may be reduced by switching from AC lube-oil pumps to the lower pressure and flow of the DC lube-oil pump.

Providing operators with an emergency response procedure and training them in its implementation is essential. The action an operator takes in the early stages of a fire is critical. Operators also need a safe area in which to perform their necessary actions. In many fires operators have been forced out of the control room by smoke and heat within minutes after the start of the fire. A room outside the turbine building is best. If the control room is in the turbine building it should be of fire-resistant construction, with penetrations sealed and an independent air supply available to pressurize the room and prevent smoke entry.

Finally, consider the difficulty in tracking the progress of the fire due to smoke limiting visibility. Operators may not know if the fire is controlled. Consider the use of thermal imaging cameras.

3.5 Fuel Supply System

3.5.1 Fuel Shutoff Valve Leakage

Fuel shutoff valves are typically fail-safe (i.e., fail-closed) valves and may also control fuel flow or pressure. Excessive leakage through fuel shutoff valves can lead to fires or explosions in the gas turbine exhaust system. Causes of excessive leakage include, but are not limited to, the following:

- A. Fouling of valve seats with contaminated fuel
- B. Out-of-calibration servo control cards
- C. Faulted or out-of-calibration instrumentation
- D. Worn components including position sensors
- E. Contaminated hydraulic fluid
- F. Assembly errors after valve maintenance

3.5.2 Fuel Shutoff Valve Leakage Testing

The following are examples of methods that can be used to ensure the shutoff valves in gaseous fuel systems meet the original equipment manufacturer's (OEM's) operational leakage limit criteria. For each application, the time duration and allowable pressure rise or pressure decay need to be determined by the OEM as a function of fuel pressure and pipe section volume. The values in the following examples are illustrative and are included to clarify the approach.

3.5.2.1 The following is an example of how to leak test the gaseous fuel system shutoff valves in a double block and vent configuration (refer to Figure 2.5.2.1.1):

- A. Valve V1 leakage test (test sequence during shutdown to prevent excessive leakage of gas to atmosphere through vent):
 1. When the fuel system control logic shuts off the fuel, vent valve (V3) is opened, and the two fuel shutoff valves (V1 and V2) are closed.
 2. To test V1, close the vent valve (V3).
 3. Monitor the pipe section between the shutoff valves (V1 and V2) for a pressure increase. The allowable pressure increase should be within OEM's acceptance criteria. Typically, a pressure increase of more than 10 psi (0.7 bar) in 30 seconds is considered excessive.
 4. Failure of this test indicates a failure or leak in the shutoff valve V1.
- B. Valve V2 leakage test (test sequence during startup):
 1. Prior to any startup sequence, the vent valve (V3) should be open, and the fuel shutoff valves (V1 and V2) are closed.

2. To test V2 during the startup sequence, close the vent valve (V3) and open V1.
3. Close V1.
4. Monitor the pipe section between the shutoff valves (V1 and V2) for a pressure decrease. The allowable pressure decrease should be within the OEM's acceptance criteria. Typically, a pressure decrease of more than 10 psi (0.7 bar) in 30 seconds is considered excessive.
5. Since valve V1 was proved leak-tight during the preceding shutdown, failure of this test indicates that a failure or leak in downstream shutoff valve V2 may have occurred. Leakage could also have been through vent valve V3.

3.5.2.2 The following is an example of a valve-proving system for a gas turbine with gaseous fuel systems as shown in Figure 2.5.2.1.2(A) and (B):

A. Valve V2 leakage test (test sequence during shutdown):

1. Gas vent valves (V4 and V5) are opened, and the three fuel shutoff valves (V1, V2, and V3) are closed when the fuel system control logic shuts off the fuel.
2. To test V2, close both vent valves (V4 and V5) and open V1.
3. Monitor the pipe section between the middle and most downstream shutoff valves (V2 and V3) for a pressure increase. The allowable pressure decrease should be within the OEM's acceptance criteria. Typically, a pressure increase of more than 10 psi (0.7 bar) in 30 seconds is considered excessive.
4. Failure of this test indicates that a failure or leak in the middle shutoff valve (V2) has occurred.

B. Valve V3 leakage test (test sequence during startup):

1. Prior to any startup sequence, both gas vent valves (V4 and V5) are open, and the three fuel shutoff valves (V1, V2, and V3) are closed.
2. To test V3 during the startup sequence, close both vent valves (V4 and V5) and open V1 and V2.
3. Close V1 and V2 and open V4.
4. Monitor the pipe section between the middle and most downstream shutoff valves (V2 and V3) for a pressure decrease. The allowable pressure decrease should be within the OEM's acceptance criteria. Typically, a pressure decrease of more than 10 psi (0.7 bar) in 30 seconds is considered excessive.
5. Failure of this test indicates that a failure or leak in the most downstream shutoff valve (V3) may have occurred. Leakage could also have been through vent valve V5.

4.0 REFERENCES

4.1 FM

Data Sheet 1-11, *Fire Following Earthquake*
Data Sheet 1-21, *Fire Resistance of Building Assemblies*
Data Sheet 1-29, *Roof Securement and Above Deck Roof Components*
Data Sheet 1-44, *Damage Limiting Construction*
Data Sheet 2-0, *Installation Guidelines for Automatic Sprinklers*
Data Sheet 2-81 *Fire Protection System Inspection, Testing, and Maintenance*
Data Sheet 3-7, *Fire Protection Pumps*
Data Sheet 4-0, *Special Protection Systems*
Data Sheet 4-1, *Fixed Water Spray Systems for Fire Protection*
Data Sheet 4-2, *Water Mist Systems*
Data Sheet 4-9, *Halocarbon and Inert Gas (Clean Agent) Fire Extinguishing Systems*
Data Sheet 4-11, *Carbon Dioxide Extinguishing Systems*
Data Sheet 4-12, *Foam-Water Sprinkler Systems*
Data Sheet 5-4, *Transformers*
Data Sheet 5-23, *Design and Protection for Emergency and Standby Power Systems*
Data Sheet 5-31, *Cables and Bus Bars*
Data Sheet 5-32, *Data Centers and Related Facilities*

Data Sheet 5-40, *Fire Alarm Systems*
Data Sheet 5-48, *Automatic Fire Detection*
Data Sheet 5-49, *Gas and Vapor Detectors and Analysis Systems*
Data Sheet 7-29, *Ignitable Liquid Storage in Portable Containers*
Data Sheet 7-32, *Ignitable Liquid Operations*
Data Sheet 7-50, *Compressed Gases in Portable Cylinders and Bulk Storage*
Data Sheet 7-54, *Natural Gas and Gas Piping*
Data Sheet 7-55, *Liquefied Petroleum Gas (LPG) in Stationary Installations*
Data Sheet 7-59, *Inerting and Purging Vessels and Equipment*
Data Sheet 7-83, *Drainage Systems for Ignitable Liquids*
Data Sheet 7-88, *Ignitable Liquid Storage Tanks*
Data Sheet 7-95, *Compressors*
Data Sheet 7-98, *Hydraulic Fluids*
Data Sheet 7-99, *Heat Transfer Fluid Systems*
Data Sheet 7-101, *Fire Protection for Steam Turbines and Electric Generators*
Data Sheet 13-17, *Gas Turbines*
Data Sheet 9-0, *Maintenance and Inspection*
Data Sheet 9-7, *Property Conservation*
Data Sheet 10-0, *The Human Factor of Property Conservation*
Data Sheet 10-1, *Pre-incident Planning*
Data Sheet 10-3, *Hot Work Management*
Data Sheet 10-4, *Contractor Management*

4.2 Other

American Society of Mechanical Engineers (ASME). *Power Piping*. ASME B31.1.

American Society of Mechanical Engineers (ASME). *Process Piping Guide*. ASME B31.3.

APPENDIX A GLOSSARY OF TERMS

Aeroderivative Gas Turbine: A unit derived from an aircraft jet or fanjet engine. Typically the gas generator section will be derived from an aircraft engine and the balance of the turbine designed for power (drive) applications.

Compressed Air Foam (CAF) System: A CAF system consists of a piping system separate from the sprinkler system, an air supply, a foam concentrate supply, a water supply, a mixing system, a detection system and a control panel. When installed for ignitable liquid fire protection, they use the same concentrate as a foam-water sprinkler system. A major advantage to this type of system is that it uses significantly less foam concentrate to produce very high-quality foam. Testing has shown that the delivered foam is very resistant to sprinkler discharge breaking up the blanket. These systems are a supplement to an automatic sprinkler system.

Enclosed installation: A gas turbine installation in which all major components and systems (except the driven machine) are housed in an enclosure. For larger units there could be several enclosures, one enclosure for each of the major systems. It is sometimes referred to as a package installation, because it is arranged on a structural skid for transportation as a unit.

External Fire or Explosion: A fire occurring outside the gas turbine. In most cases damage is to piping, cable or external surfaces of the turbine. The enclosure housing the turbine may also be damaged. Fires involve leaks of oil at bearing housings or insulation blanket fires are usually high value fires. Fires involving leaks or breaks in lube-oil or fuel lines are usually high value fires. Gas line leaks or breaks generally result in an explosion followed by a fire.

Flameout: General loss of flame in a gas turbine combustor, possibly because of restriction in the fuel lines to the combustor section or a control malfunction that reduces fuel flow below the lower limit of combustion.

FM Approved: References to "FM Approved" in this data sheet mean the products and services have satisfied the criteria for FM Approval. Refer to the *Approval Guide*, an online resource of FM Approvals, for a complete listing of products and services that are FM Approved.

FM Approved Industrial Fluid: A lubricant or hydraulic fluid that has demonstrated a limited heat release rate and an inability to stabilize a spray flame when tested according to FM Approvals Standard 6930,

Approval Standard for Flammability Classification of Industrial Fluids. FM Approved industrial fluids do not in and of themselves require fire protection measures.

Foam-Water Sprinkler System: A foam-water sprinkler system consists of a closed or open head sprinkler system that is connected to a low-expansion foam concentrate proportioning system designed to deliver a fixed foam concentration. The major advantage to installing a foam system is that it can be added to an existing sprinkler system. Closed and open head foam-water sprinkler systems are described in Data Sheet 4-12, *Foam-Water Sprinkler Systems*.

Gas turbine installation: The arrangement of a gas turbine and its driven machine (usually an electric generator or compressor) in a facility. The installation is usually understood to include a lubrication system for the machinery bearings, a hydraulic system for certain control and protective functions, liquid fuel and gaseous fuel conditioning and delivery systems, a fire protection system, switchgear and a control room. The air intake and filter, including silencer and air cooling system, and the exhaust duct and silencer, are part of the installation.

Hybrid (Water and Inert Gas) System: A special protection system that delivers a combination of water and an inert gas (consisting of one or more of the gases helium, neon, argon, nitrogen, and carbon dioxide) through a distribution system. Both the water and the inert gas are critical factors in fire extinguishment, for the purposes of cooling and inerting.

Ignitable Liquid: Any liquid or liquid mixture that will burn. A liquid will burn if it has a measurable fire point. Ignitable liquids include flammable liquids, combustible liquids, inflammable liquids, or any other term for a liquid that will burn.

Industrial (frame) Gas Turbine: Any gas turbine manufactured solely for use in industry. The larger machines are referred to as "heavy-duty gas turbines" and the smaller units as "packaged gas turbines."

Inert gas: An extinguishing agent constituted of the inert gases argon, nitrogen, helium or neon. A blended agent may also include carbon dioxide.

Internal Fire or Explosion: A fire occurring inside one of the major components of the turbine usually due to fuel accumulations. Fuel may accumulate due to fuel leakage past shutoff valves, delay in shutdown following loss of flame, failure of a casing drain, or an inadequate purge. The fire or explosion occurs within the turbine, compressor or exhaust system.

Lagging: The term "lagging" refers to a covering or enclosure of some kind designed to shield the hot section of a gas turbine from external factors, such as other equipment, water discharge, or simply the environment, and to keep personnel from accidental contact with the hot section while the turbine is operating. Lagging consists of insulating blankets around the casing. The insulation is usually metal covered.

Proof of Closure Switch: A device that provides feedback that a piece of equipment is in the closed position.

Purge Credit: A condition that is established by maintaining a set of parameters following a gas turbine normal shutdown that allows the gas turbine to restart without going through a unit purge.

Rundown Time: Following a trip of the turbine, the period during which the unit is coasting down from its operating speed to a shutdown condition (typically, once the equipment has been placed on turning gear). Lubrication oil may continue to be supplied to the equipment during this period.

Safe Shutdown: Following the emergency response team's assessment of the fire event, a decision to initiate a prompt shutdown of the equipment. Rotating equipment is considered "shut down" when it has reached a speed where the lubrication oil system can be turned off without damaging the equipment. Typically, this is achieved once the equipment has been placed on turning gear. Safe shutdown must be accomplished based on an evaluation of the site specific oil system design, the turbine manufacturer's emergency shutdown system, and emergency response procedures.

Skid: A structural steel base on which a gas turbine and/or its auxiliary components are mounted. It may be enclosed or unenclosed.

Spray Barrier: A metal barrier located between a spray source and critical equipment serving to deflect a horizontal spray.

Spray Fire Shield: A device placed around the flanges of pressurized piping systems, used to prevent highly pressurized jets of fluid. The shield is designed to prevent a spray fire from developing by converting a highly pressurized spray into a low pressure, low momentum flow of liquid which can be controlled by a properly designed sprinkler system.

Spray Fire Source: Any unguarded flange, fitting, or control device that provides containment for pressurized combustible oil at a high pressure and is connected to a reservoir. Length of the jet flame is determined by pump capacity and assumed pressure and orifice size for the leak.

Spray Hood: A horizontally mounted barrier located above a spray source serving to deflect a vertical spray.

Total Flooding System: A fire extinguishing system that relies on filling an enclosure with an extinguishing agent, and maintaining the extinguishing concentration within the enclosure until the fire is extinguished and conditions will not permit reignition. Inert gas and carbon dioxide extinguishing systems are total flooding systems.

Unenclosed installation: A gas turbine installation, usually in a large building and possibly part of a multiple installation, without individual enclosures for any of its auxiliaries or components.

Unit Purge: A flow of air through the gas turbine and its exhaust system at a rate and duration for a sufficient number of volume changes to occur to remove any flammable vapors and replace them with the air.

Water Mist: A special protection system in which a distribution system is connected to a water supply that is capable of delivering atomized water spray with droplets that are less than 1,000 microns in size. The smaller droplets vaporize and extract heat more rapidly from flames, and are able to extinguish spray fires.

APPENDIX B DOCUMENT REVISION HISTORY

The purpose of this appendix is to capture the changes that were made to this document each time it was published. Please note that section numbers refer specifically to those in the version published on the date shown (i.e., the section numbers are not always the same from version to version).

April 2026. Interim revision. Minor editorial changes were made.

July 2025. Interim revision. Minor editorial changes were made.

July 2022. Interim revision. The following significant changes were made:

- A. Added recommendations for designing water mist systems that have been FM Approved for local application over oil pool and 2D spray fire areas.
- B. Updated cable fire protection to associate fire protection rating to safe shutdown time.
- C. Added recommendations for oil conditioning skids.

January 2018. Interim revision. Minor editorial changes were made.

January 2018. Minor editorial changes were made.

July 2013. The following major changes have been made.

- A. The title of the document has been changed from *Fire Protection for Combustion Turbine Installations* to *Fire Protection for Gas Turbines and Electric Generators*.
- B. References to “combustion turbine” have been replaced with “gas turbine” throughout the document.
- C. References to “flammable” and “combustible” liquids have been replaced with “ignitable liquids” throughout the document.
- D. The document has been reorganized where necessary to provide a format that is consistent with other data sheets.
- E. Recommendations for structural steel protection, including where protection is necessary, have been clarified.
- F. Recommendations for containment and emergency drainage have been clarified.

G. An option to provide containment of mineral oil without the need for emergency drainage has been added. This option is contingent on several other factors, such as the design of the containment and automatic fire protection features.

H. The intent of cable protection guidance has been clarified. The use of FM Approved cable coatings as a protection method has been removed.

I. Recommendations related to electric generators have been added.

J. The necessary discharge duration for special extinguishing systems has been clarified.

K. Hybrid (water and inert gas) fire extinguishing systems have been added as options for the protection of gas turbine compartments.

L. Automatic sprinklers and water spray have been removed as options for the protection of gas turbine compartments.

M. Information on acceptance testing of special extinguishing systems has been added.

N. The fire protection recommendations for unenclosed turbines have been modified.

O. Additional general information on the design of sprinkler systems has been added, including guidance on spacing and sprinkler system types.

P. Compressed air foam (CAF) systems have been added as an alternative to emergency drainage and for supplemental protection of the turbine building.

Q. The intent of an Oil Fire Hazards Assessment has been clarified.

R. A discussion of ignition sources and information regarding which compartments need fire protection has been added to Section 3, Support for Recommendations.

S. Recommendations for gas turbine fuel train arrangements and combustion safeguards have been added.

T. Recommendations on how to address hydrogen, ignitable liquid, fuel gas, and sprinkler piping systems in areas exposed to earthquakes have been added.

U. Recommendations for hose streams to be included in the capacity of drains and containment have been removed.

September 2010. Minor editorial changes were made for this revision.

May 2010. Minor editorial changes were done for this revision.

January 2008. The following changes have been made:

Design criteria for turbine building sprinkler systems have been revised.

Emergency drainage and containment design criteria have been revised to account for potential fire scenarios where more than 10 minutes of sprinkler and hose stream discharge is expected.

A recommendation has been added to provide FM Approved flange shields and deflectors to help mitigate exposures from oil spray fires.

The design extinguishing period for special extinguishing systems protecting turbine compartments has been revised. Refer to sections 2.4.3.2 and 3.3.2.3.

May 2000. The following changes were made:

1. The recommendation for excess flow valves as an alternate form of protection to fixed fire protection has been removed. Excess flow valves function if the flow exceeds 110% of the rated flow. There have been large losses in which oil or fuel leakage from a flange or a fitting has been substantially less than the rated flow. Excess flow valves may be of benefit in installations such as engine test cells where the frequency of a catastrophic event is substantially higher than in production machines.

2. A requirement for a full discharge trip test has been included for gaseous agent extinguishing systems. In addition an inspection program for doors and damper intended to seal openings is recommended. The causes of previous extinguishing system failures are reported. Also the results of a recent survey of loss prevention engineers specializing in fire protection for utilities indicate that the reliability of these systems is

substantially improved when full discharge trip tests are conducted.

3. Protection of one set of control and power cable for ac and dc lube oil pumps is recommended.
4. Fixed fire protection system agent supply should be 10 min or the rundown time of the turbine for enclosed turbines whichever is greater. Local application system agent supply should be 20 min or the rundown time of the turbine whichever is greater.
5. Automatic sprinkler or water spray protection is recommended as an alternate form of protection providing the system is arranged to prevent water discharging onto the turbine casing.
6. An annual test frequency is recommended for automatic drains in combustor casings.
7. Descriptions of tests and losses involving automatic sprinkler protection have been revised and examples of the need to functionally test gaseous agent systems have been added.

The September 1998 revision recommended:

- The use of excess flow check valves in lubrication, hydraulic and liquid-fuel systems.
- Fine-water spray (FWS) extinguishing systems
- The use of less flammable lubricants and hydraulic fluids
- Direct fire protection of the main structural members of turbine halls.