

FIRE PROTECTION FOR STEAM TURBINES AND ELECTRIC GENERATORS

Table of Contents

	Page
1.0 SCOPE	4
1.1 Changes	4
2.0 LOSS PREVENTION RECOMMENDATIONS	4
2.1 Introduction	4
2.2 Construction and Location	4
2.2.1 General	4
2.2.2 Protection of Structural Steel	4
2.2.3 Containment and Emergency Drainage	6
2.2.4 Lubrication-Oil, Hydraulic-Oil, and Seal-Oil Systems	7
2.2.5 Lubrication, Control, and Seal-oil Piping	10
2.2.6 Hydrogen Supply for Electric Generator Cooling	11
2.2.7 Electrical Rooms and Transformers	11
2.2.8 Control Rooms and Associated Equipment	12
2.3 Occupancy	13
2.3.1 Housekeeping	13
2.3.2 FM Approved Industrial Fluids	14
2.3.3 Hydrogen Supply for Electric Generator Cooling	14
2.3.4 Protective Equipment	14
2.3.5 Grouped Cables and Cable Spreading Rooms	14
2.3.6 Earthquake	14
2.4 Protection	15
2.4.1 General	15
2.4.2 Fire Protection for Oil Spray Fires	16
2.4.3 Fire Protection from Pool and Three-Dimensional Spill Fires	17
2.4.4 Protection on Operating Floors	24
2.4.5 Enclosed Steam Turbines or Generators	26
2.4.6 Water Mist Systems for Oil Fire Hazards in Unenclosed Areas	26
2.4.7 Combustible Roof Protection	28
2.4.8 Outdoor Units	28
2.4.9 Boiler Feed Pumps, Turbine and Electric Drivers, and Variable Speed Couplings	28
2.4.10 Relay and Cable Spreading Rooms and Transformers	28
2.4.11 Control Rooms and Distributed Control System (DCS) Rooms	28
2.5 Operation and Maintenance	29
2.5.1 Fire Prevention	29
2.5.2 Emergency Shutdown Procedure	29
2.5.3 Spray Fire Shield Inspection and Maintenance	29
2.5.4 Oil Fire Hazards Assessment (OFHA)	29
2.6 Training	30
2.6.1 Employee Training	30
2.6.2 Contractor Training	30
2.7 Human Factor	30
2.7.1 Supervision of Programs	30
2.7.2 Supervision of Contractors	30
2.7.3 Plant Inspections	31
2.7.4 Emergency Response and Pre-Incident Planning	31
2.7.5 Audits and Management of Change	31



2.8 Ignition Source Control	32
2.8.1 Hot Work	32
2.8.2 Other Ignition Sources	32
3.0 SUPPORT FOR RECOMMENDATIONS	32
3.1 General	32
3.1.1 Release Sources	32
3.1.2 Ignition Sources	32
3.1.3 Oil Fire Hazards	33
3.1.4 FM Approved Industrial Fluids	34
3.1.5 Oil Fire Hazards Assessment (OFHA)	35
3.2 Location and Construction Safeguards	38
3.2.1 Site Layout and Equipment Arrangements	38
3.2.2 Structural Steel Protection	38
3.2.3 Spill Containment and Emergency Drainage	38
3.3 Automatic Fire Protection	39
3.3.1 Special Extinguishing Systems	39
3.3.2 Automatic Sprinkler Systems	39
3.3.3 Emergency Shutdown Procedure	39
3.4 Loss History	39
4.0 REFERENCES	40
4.1 FM	40
4.2 Others	40
APPENDIX A GLOSSARY OF TERMS	40
APPENDIX B DOCUMENT REVISION HISTORY	41
APPENDIX C TURBINE OIL SYSTEMS	43
C.1 Lube-Oil Systems	43
C.1.1 Mineral Oil	43
C.1.2 "Fire-Resistant" Lubricants	44
C.1.3 Control-Oil Systems	44
C.1.4 Seal-Oil Systems	45
C.2 Generators	45
C.3 Isolated Phase Bus	45

List of Figures

Fig. 1a. Elevated lube oil reservoir shows protection of exposed steel.	5
Fig. 1b. Water spray protection for steel columns	6
Fig. 2. Fire protection and drainage for island type turbine-generator	7
Fig. 3. Cable protection for dc lube oil pump	8
Fig. 4. Lube oil purifying skid inside containment area	9
Fig. 5. Guard piping	10
Fig. 6. Protection of electrical equipment from mineral oil fire exposure	12
Fig. 7. Control room protection and protection of cable for remote turbine shutdown	13
Fig. 8. Protection for medium size turbine generator with floor openings near mineral oil systems needing spray fire protection	17
Fig. 9a. Protection for turbine buildings with solid operating floors	18
Fig. 9b. Optional protection for turbine buildings with solid operating floors higher than 30 ft (9.1 m)	18
Fig. 9c. Protection for turbine buildings with solid operating floor and grated mezzanines below	20
Fig. 9d. Protection for turbine buildings with solid operating floor and solid floor mezzanines	21
Fig. 9e. Local protection for island type turbine buildings	22
Fig. 9f. Protection for island-type turbine buildings with roof height within Table 1 or less	22
Fig. 9g. Local protection for solid pedestal designs	23
Fig. 9h. Protection for solid pedestal designs with roof height within Table 1 or less	24
Fig. 10. Protection for bearing housing and areas under turbine skirts	25
Fig. 2.4.6.2.1. Typical layout of a water mist system for local application over oil fire hazards (NOTE: Shaded areas are not solid barriers, but areas of operation.)	27
Fig. 11. Mineral oil spray fire (90 psig [6 barg]) demonstration test	34
Fig. 12. Walk-down of oil system showing release and flow path	36

Fig. 13. Suggested outline for development of oil release and fire scenarios 37

List of Tables

Table 1. Sprinkler Densities for Pool Oil Fires 19

Table 2. Ceiling Sprinkler Design Criteria for Turbine Buildings with Combustible Roof Construction 28

1.0 SCOPE

This data sheet includes fire protection and prevention recommendations for fire hazards related to steam turbines and electric generators. Recommendations for turbine monitoring devices, maintenance and testing, and other equipment safeguards are provided in Data Sheet 13-3, *Steam Turbines*. For information regarding driven equipment other than electric generators, use this data sheet in conjunction with other applicable data sheets (e.g., refer to Data Sheet 7-95, *Compressors*, for information on compressors).

1.1 Changes

April 2026. Interim revision. Minor editorial changes were made.

2.0 LOSS PREVENTION RECOMMENDATIONS

2.1 Introduction

Severe fires involving steam turbines and electric generators occur as a result of the accidental release and ignition of mineral oil from lubrication-, control-, or seal-oil systems, and the release of hydrogen from the generator.

Experience has shown that severe damage can occur to the turbine, generator, and turbine building unless they are adequately protected. The safeguards recommended in this data sheet address oil fire hazards by using a layered approach consisting of prevention programs, fixed protection, and an emergency shutdown procedure. Actual implementation will depend on site-specific conditions. The major safeguards to consider are the following:

- A. Local and under-floor area automatic sprinkler protection where oil could spray or leak.
- B. Containment and drainage to limit the area involved.
- C. An effective emergency shutdown plan and adequate operator training to secure the unit so lube-oil pumps can be shut off as quickly and safely as possible in the event of a fire.
- D. Location of control rooms outside the turbine building when possible. Protection of control rooms located in turbine buildings to provide operators the opportunity to take action during a fire.
- E. Protection of power and control cables for the DC lube-oil pump to minimize the possibility of uncontrolled loss of lubrication systems.
- F. Use of an FM Approved industrial fluid for control- and seal-oil systems. This will eliminate the need for fixed fire protection systems for the oil hazard associated with these two systems. In most cases fire protection will be limited to that needed to protect grouped cables and exposure from mineral oil-based lube-oil systems.

Use FM Approved equipment, materials, and services whenever they are applicable. For a list of products and services that are FM Approved, see the Approval Guide, an online resource of FM Approvals.

2.2 Construction and Location

2.2.1 General

2.2.1.1 Construct turbine buildings of noncombustible or fire-resistant materials.

2.2.1.2 Construct a noncombustible roof or an FM Approved Class 1 steel deck roof, designed and installed per Data Sheet 1-29, *Roof Securement and Above-Deck Roof Components*, and the roof system's *Approval Guide* listing.

2.2.2 Protection of Structural Steel

2.2.2.1 Protect critical steel elements that can potentially be immersed in a liquid pool and/or three dimensional spill fire (e.g., structural building columns, supports for turbine pedestals and elevated lube-oil reservoirs, supports for equipment mezzanines, and overhead crane rails) using one of the methods below. Determine the need for structural steel protection based on an Oil Fire Hazards Assessment (OFHA), including consideration of containment, drainage, and oil-release scenarios.

A. Provide fireproofing rated for two hours. Provide fireproofing that is rated for a hydrocarbon fire exposure for the full height of the column. (See Data Sheet 1-21, *Fire Resistance of Building Assemblies*.) general, the fire rating of a structural element provided with an ordinary fire-resistive covering will be the stated fire rating (h) minus 1 hour (h-1 = fire resistance of a steel column exposed to a hydrocarbon pool fire).

B. Provide automatic (fusible link) sidewall sprinklers or water spray protection for the full height of the column, as shown in Figures 1a and 1b.

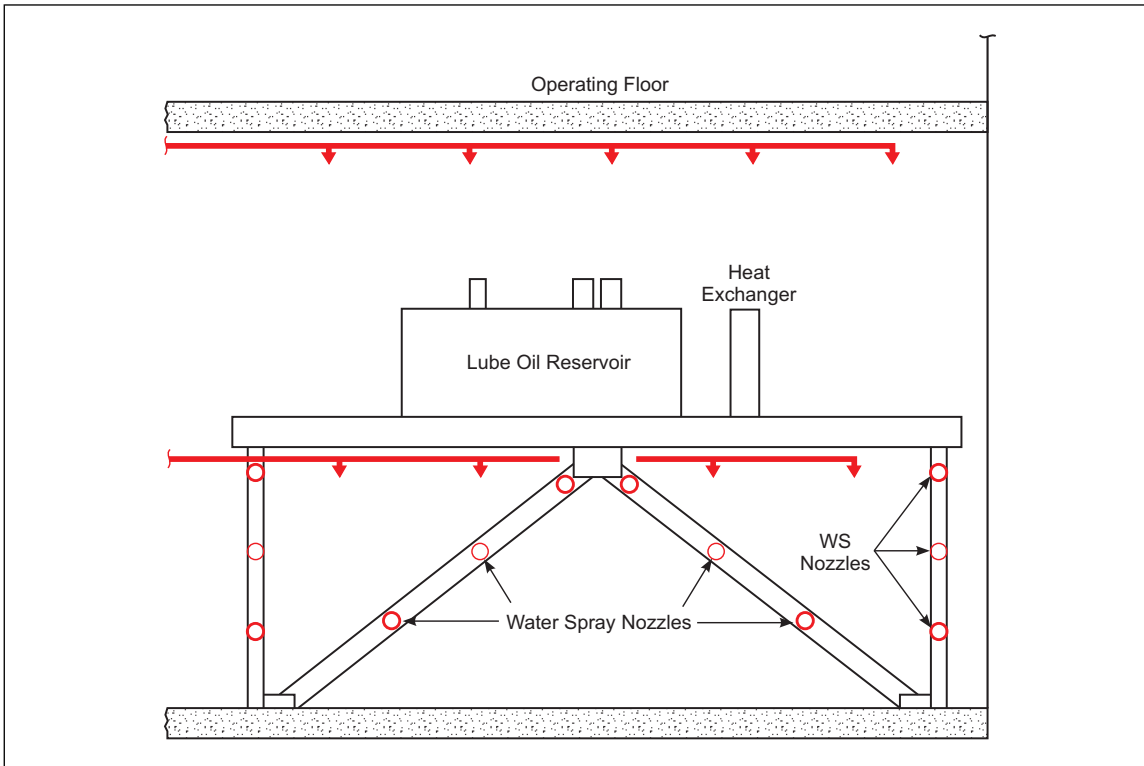

Fig. 1a. Elevated lube oil reservoir shows protection of exposed steel.

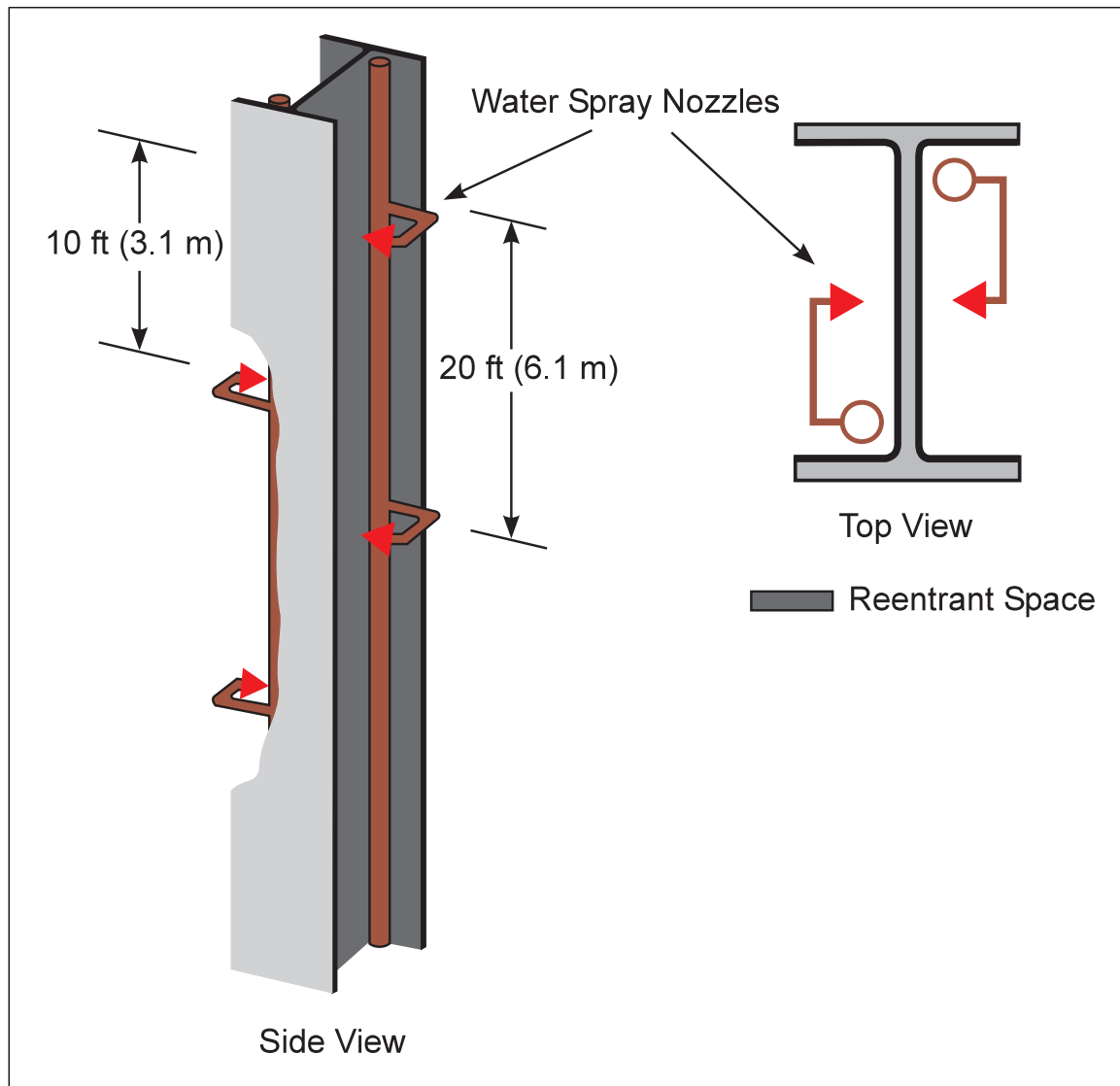

Fig. 1b. Water spray protection for steel columns

Provide a minimum 0.3 gpm/ft^2 (12 mm/min) over the wetted area of the columns ("wetted area" is the surface area on the three sides of the reentrant space formed by the column web and flanges). The wetted area protected by a sprinkler extends from the sprinkler down to the next sprinkler on the same side of the column.

Include flow from all nozzles on columns subject to simultaneous flame impingement in the design flow rate when determining total water demand. Use information from an OFHA to determine which columns could be subject to simultaneous flame impingement. Consider simultaneous operation of structural steel protection and turbine lube-oil fire protection to determine total water demand (refer to Section 2.4.1.1).

2.2.3 Containment and Emergency Drainage

2.2.3.1 Provide emergency drainage and containment in order to limit fire areas and protect important turbine installations from fire involving the release of lubrication oil and hydraulic fluid that are not FM Approved. Provide one of the following options:

- A. Provide containment and emergency drainage to achieve the following objectives:

1. Rapidly remove released liquids, including the oil flow rate and water from sprinkler discharge, to a safe location.
2. Provide curbing and drains to a safe location for potential liquid releases from lubrication-, seal-, and control-oil reservoirs, and pump and equipment enclosures.
3. Use drains and curbs to prevent releases from flowing to and exposing adjacent equipment areas such as auxiliary equipment skids and compartments, cable trays and electrical switchgear, and subfloor spaces. Refer to Figure 2 for an example of an emergency drainage and containment system for an island-type turbine generator.
4. Provide drains and curbs to prevent released fluids from overflowing and spilling onto floors and mezzanines below the origin of the release.
5. Prevent fires from spreading to unsprinklered areas.

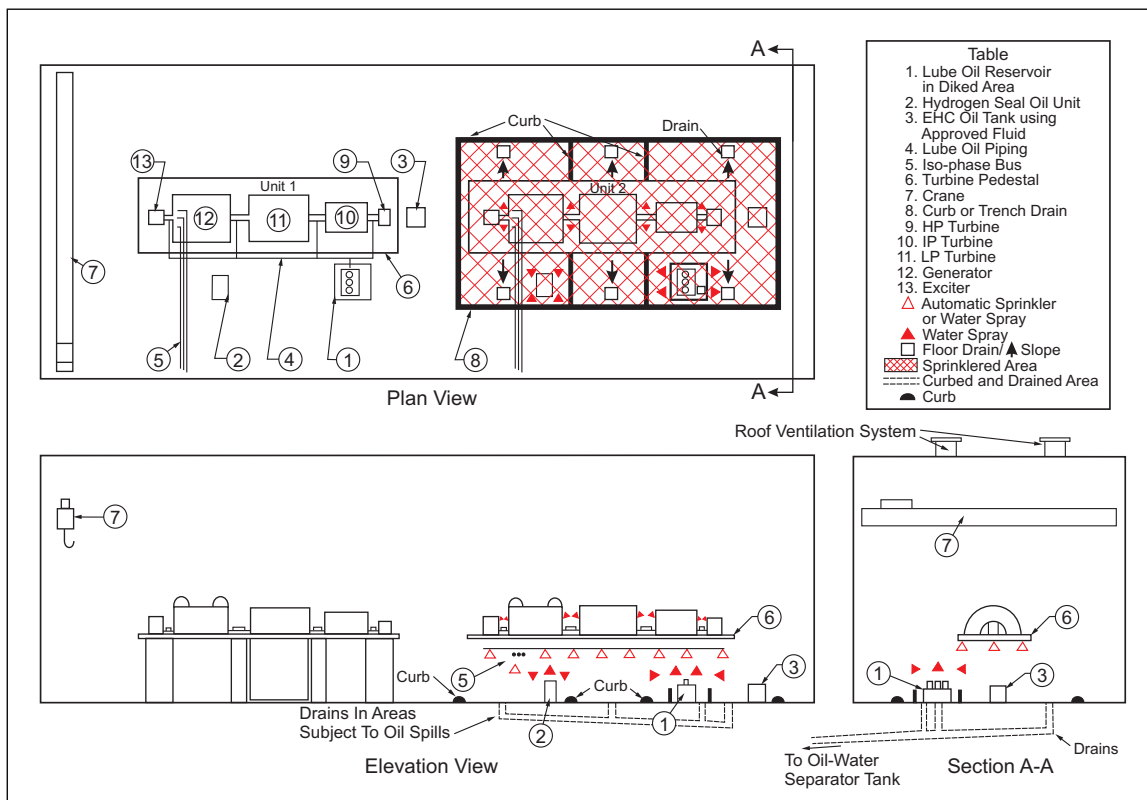

Fig. 2. Fire protection and drainage for island type turbine-generator

B. Provide containment and an FM Approved foam-water sprinkler system or compressed air foam (CAF) system. Design the containment to keep the largest expected oil release plus foam/sprinkler discharge in the area of origin for 20 minutes. Regardless of the calculated curb height, always provide a minimum 3 in. (7.6 cm) of containment.

2.2.3.2 Design emergency drainage and containment systems in accordance with Data Sheet 7-83, *Drainage and Containment Systems for Ignitable Liquids*.

2.2.4 Lubrication-Oil, Hydraulic-Oil, and Seal-Oil Systems

Provide the following location and construction safeguards where mineral oil or other non-FM Approved fluids are used.

2.2.4.1 Locate oil systems, including reservoirs, storage tanks, pumps, conditioning equipment (coolers, oil filtration, and centrifuge systems) in a separate fire area from the turbine, preferably outside the turbine building.

2.2.4.2 If oil reservoirs, conditioning equipment, and pumps cannot be located outside the turbine building, provide a cutoff room of at least 1-hour fire-rated construction, with emergency drainage and containment, along an outside wall and with direct access from outside the turbine building.

2.2.4.3 Locate any indoor main lube-oil storage tanks in a separate cutoff room in accordance with Data Sheet 7-32, *Ignitable Liquid Operations*.

2.2.4.4 Where applicable, provide the following for power and control cables for critical functions, such as lubrication of the turbine and power for hydrogen seal-oil pumps:

- A. Route the cables to minimize exposure to potential oil fires.
- B. Locate control and instrumentation cables for individual units so as to minimize the chance a fire will result in an extended outage to multiple units.
- C. Provide separate routing of cables for primary (AC) and backup (DC) lube-oil pumps (see Figure 3).
- D. Provide an FM Approved fire blanket for backup cables (DC) that cannot be routed separately, and for cables that enter within the same pool or spill-fire area, including cabling within conduit.
 1. Provide a blanket having a fire protection rating equal to or greater than the maximum projected time for safe shutdown of the system plus 10 minutes.
 2. Document the fire rating and methodology in the emergency operating procedure.
 3. Ensure the fire blanket includes the flexible conduit used to route the cables from the pump to the junction box.
 4. Provide the fire blanket for 20 ft (6.1) beyond the fire area (see Figure 3). Verify the blanket will not result in cable de-rating.

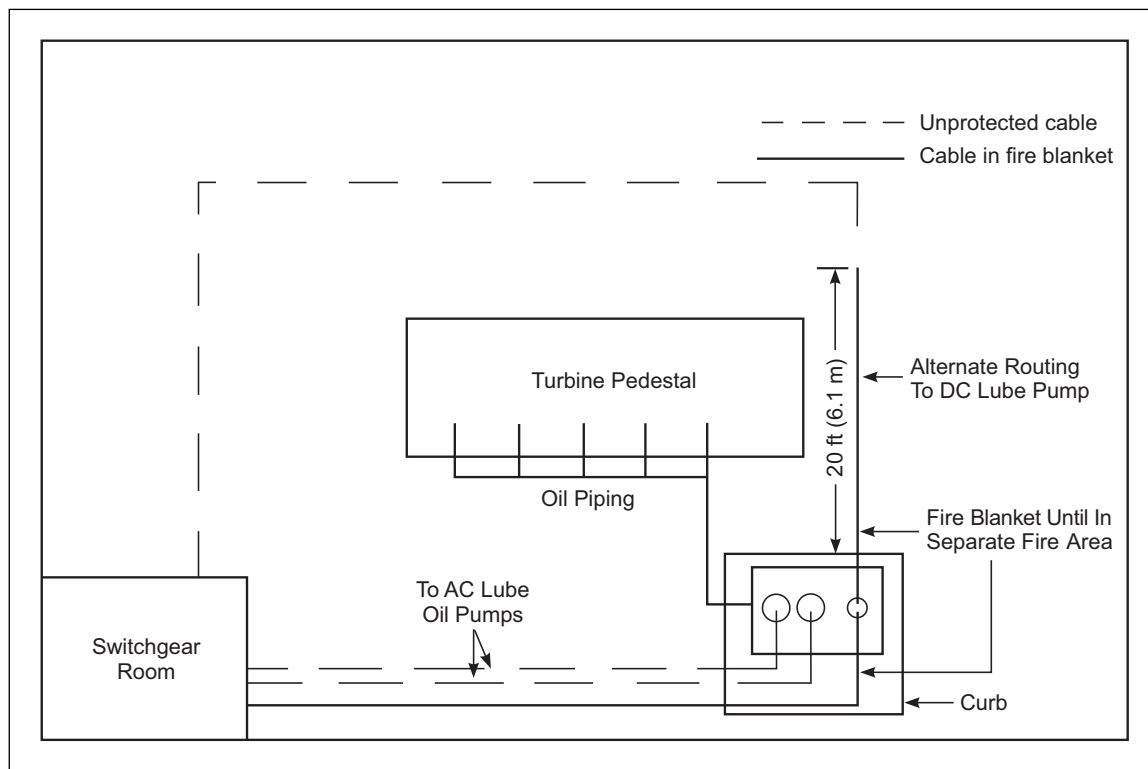

Fig. 3. Cable protection for dc lube oil pump

2.2.4.5 Oil Conditioning, Purifying, Cleaning, or Varnishing Skids

2.2.4.5.1 Install skids used for oil conditioning within the containment area, or within the protected fire area of the lube oil skid (see Figure 4).



Fig. 4. Lube oil purifying skid inside containment area

2.2.4.5.2 If the skid cannot be located within the lube oil containment area, provide separate containment for the skid. Where separate containment is used, install an FM Approved leak detection system on the feed side to the polisher arranged to automatically shut down oil flow in the event of a leak.

2.2.4.5.3 Where the skid is not located within the oil fire protected area, provide fire protection over the oil conditioning skid in accordance with the spray or pool fire recommendations as applicable.

2.2.4.5.4 Install FM Approved fire-safe, fire-actuated valves for feed and discharge lines to and from the oil conditioning skid. Locate these valves within the main lube oil tank containment area.

2.2.4.5.5 Provide flexible hose connectors in piping systems to prevent dangerous stresses due to vibration, settling, or thermal change. Provide the following material and installation features to ensure adequate hose strength/durability and protection against physical damage:

A. Construct flexible hose of high-strength, noncombustible materials that are resistant to decomposition or melting when exposed to fire, and compatible with the liquid in use.

1. Use all-metal construction consisting of materials such as steel, stainless steel, or an equivalent material.
2. Reinforced plastic or rubber hose, and a tight metal-braid covering is acceptable when needed to meet operational requirements. See Data Sheet 7-32, *Ignitable Liquid Operations*, for further information.
3. Do not use soft rubber, plastic, or other unreinforced or unprotected combustible tubing.

B. Protect the hose against mechanical damage.

C. Design hose joints to comply with all rigid pipe joint recommendations (see Data Sheet 7-32). Do not use hose clamps.

D. Design hoses and fittings to have a bursting strength greater than the maximum expected working pressure, with a safety factor of at least 4.

2.2.5 Lubrication, Control, and Seal-oil Piping

2.2.5.1 Design and install oil piping to minimize chances of a break in a pipe or fitting in the event of turbine vibration.

- A. Weld piping for lubricating, seal, and control-oil systems where possible.
- B. Install supply piping inside drain or guard piping (Figure 5), inside steel-welded enclosures, or in covered trenches designed to return leaked oil to a protected collection point.
- C. Locate oil piping on the opposite side of the unit from steam lines and other ignition sources. If piping must be on the same side, locate oil lines below steam lines.
- D. Cover insulation on adjacent steam piping or hot metal parts with sheet metal or replace with a type impervious to oil.
- E. Properly support and brace oil piping and protect instruments, controls and associated fittings against mechanical damage.

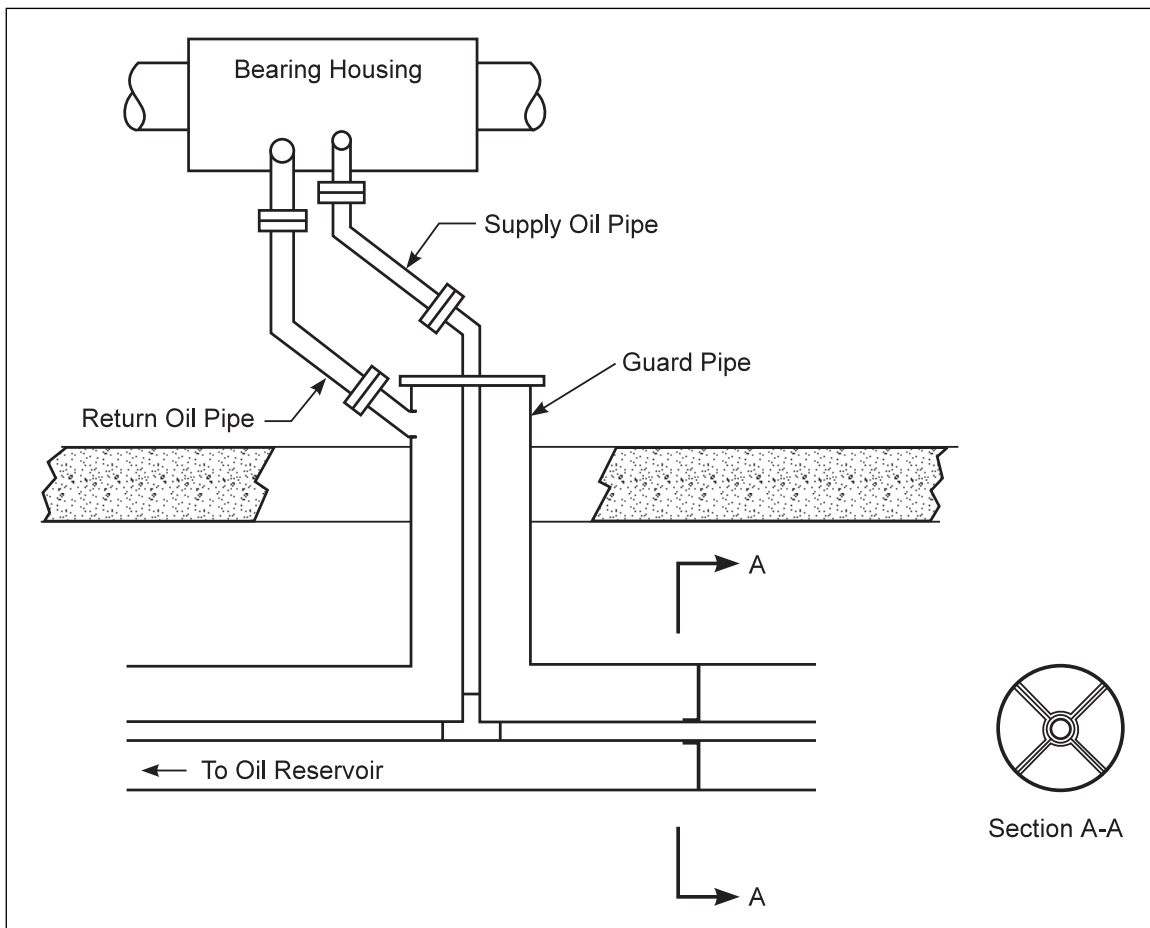

Fig. 5. Guard piping

2.2.5.2 Rubber Expansion Joint (Bellows)

Rubber bellows have been installed on some lube-oil supply systems. They may be installed anywhere in supply oil piping for alignment purposes or to reduce vibration. Failure of a rubber bellows, either from external fire exposure or from wear, has resulted in significant releases of oil.

- A. Replace rubber bellows with a metal expansion joint or stainless steel braided hose. Consult the turbine manufacturer for recommended equipment.

B. Provide a containment device (sleeve) around the rubber bellows until the bellows can be replaced.

2.2.5.3 Provide unlatched hinged covers for oil tanks associated with hydrogen seal-oil equipment.

2.2.5.4 Earthquake

2.2.5.4.1 In areas exposed by earthquakes, do not install seismic shutoff switches for lube-oil systems. Refer to Data Sheet 1-11, *Fire Following Earthquake*, for further information regarding the omission of seismic shutoff valves.

2.2.5.4.2 Design oil piping systems to resist damage in the event of an earthquake, as follows:

A. Limit gross movement of the equipment to which the piping is connected.

B. Provide flexibility to accommodate relatively small movement at equipment, or larger movement due to piping deflection.

C. Ensure pipe movement does not result in loss of vertical supports.

2.2.6 Hydrogen Supply for Electric Generator Cooling

Where hydrogen-cooled generators are used, hydrogen gas may be supplied from standard portable cylinders, outdoor tanks or tube trailers, or from an onsite hydrogen gas generator. The following recommendations pertain to fire protection for the hydrogen supply.

2.2.6.1 Locate bulk hydrogen tanks and hydrogen tube trailers outdoors and arrange them in accordance with Data Sheet 7-91, *Hydrogen*.

2.2.6.2 Preferably, store portable cylinders outside under a fenced, access-controlled canopy. Alternatively, they may be stored in a secure, detached building in accordance with Data Sheet 7-50, *Compressed Gases in Portable Cylinders and Bulk Storage*.

2.2.6.3 If portable cylinders are to be stored inside an important building, provide a cutoff room with damage-limiting construction (DLC), continuous mechanical ventilation, gas detection, and sprinkler protection in accordance with Data Sheet 7-50, *Compressed Gases in Portable Cylinders and Bulk Storage*.

2.2.6.4 In 500-year or less frequent earthquake zones, restrain hydrogen cylinders in accordance with Data Sheet 1-11, *Fire Following Earthquake*.

2.2.6.5 If dispensing manifolds for portable cylinders are located inside the main facility, arrange them in accordance with Data Sheet 7-91, *Hydrogen*. Ensure the cylinders are not exposed to lubricating-oil fires.

2.2.6.6 Provide human-element safeguards for hydrogen cylinders in accordance with Data Sheet 7-50, *Compressed Gases in Portable Cylinders and Bulk Storage*.

2.2.6.7 Where hydrogen gas for electric-generator cooling is being generated on site, locate the gas generators outdoors or, if located indoors, in accordance with Data Sheet 7-91, *Hydrogen*.

2.2.6.8 Install an emergency shutoff valve on the hydrogen supply line. Locate the emergency shutoff valve close to the supply manifold at a readily accessible location. Also provide for remote emergency operation of the shutoff valve from the control room.

2.2.6.9 In 500-year or less frequent earthquake zones, do not install seismic gas shutoff valves for the hydrogen supply. Refer to Data Sheet 1-11, *Fire Following Earthquake*, for further information regarding the omission of seismic shutoff valves.

2.2.6.10 Design hydrogen piping systems to resist damage in the event of an earthquake in accordance with Section 2.2.5.4.2.

2.2.7 Electrical Rooms and Transformers

2.2.7.1 Locate control, instrumentation, and switchgear equipment in 1-hour fire-rated enclosures outside areas subject to fire involving turbine lubrication fluids (see Figure 6).

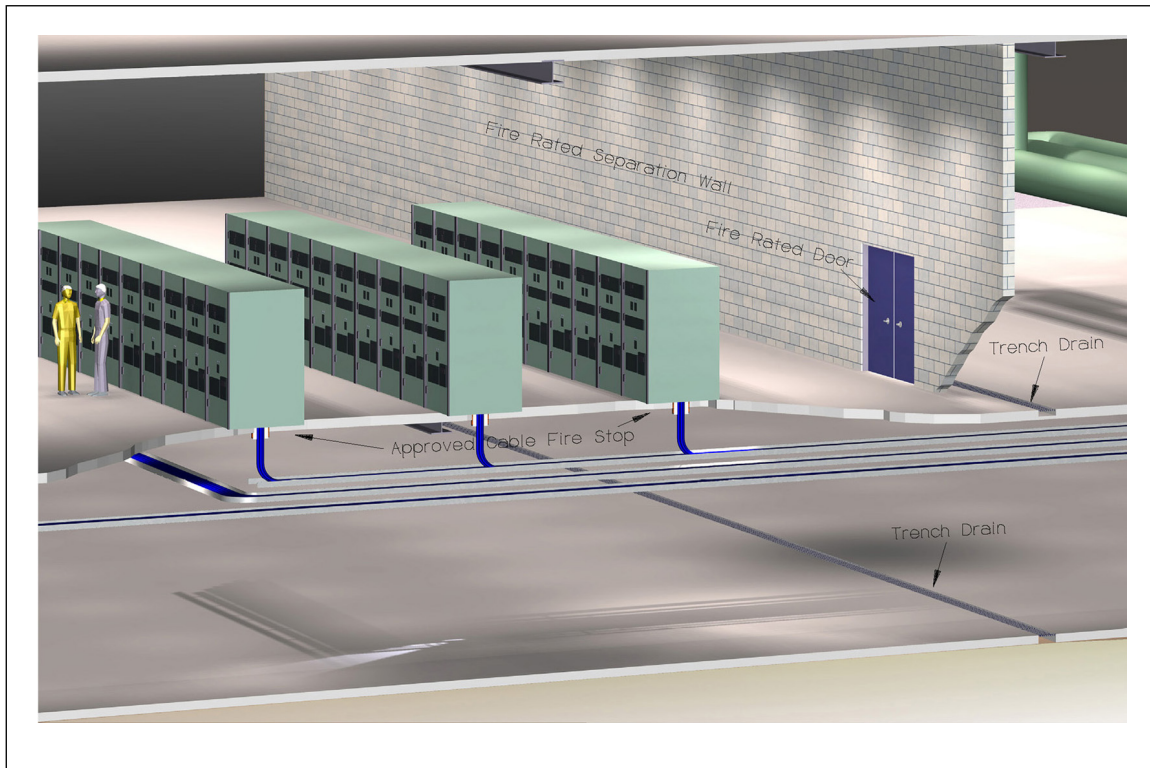

Fig. 6. Protection of electrical equipment from mineral oil fire exposure

2.2.7.2 Seal openings in floors, walls, and ceilings with an FM Approved fire-stop of 1-hour fire resistance.

2.2.7.3 Seal the walls and ceilings of exposed instrumentation and electrical rooms to prevent ingress of liquid spills and water from sprinkler/hose stream discharge.

2.2.7.4 Locate and arrange transformers in accordance with Data Sheet 5-4, *Transformers*.

2.2.8 Control Rooms and Associated Equipment

Design control rooms to minimize potential exposure damage, and to remain habitable during a fire to allow operators to take the necessary action to secure the damaged unit and adjacent units.

2.2.8.1 Locate control and cable spreading rooms in separate areas of noncombustible construction, outside the turbine building.

2.2.8.2 When a control room must be located in the turbine building, design the room as follows:

- A. Locate the control room to reduce exposure to potential lube-oil or grouped cable fires. In particular, avoid locating the control room over, under, or adjacent to lube-oil or control-oil equipment or areas where three-dimensional spill or pool fires could form.
- B. Isolate the room from the turbine building with 1-hour fire-rated walls, roof, and floor. Provide a 45-minute fire-rated window assembly, such as wired glass, rolling steel fire-rated shutters, or an automatic water spray protection system for any windows facing the interior of the turbine building (see Figure 7).
- C. Provide smoke tight sealing of windows and an independent air supply capable of pressurizing the room to maintain habitability during a fire.
- D. Seal the walls and ceilings of exposed control rooms inside turbine buildings to prevent ingress of facility water or other liquids in case of pipe breaks, spills, or water from sprinkler/hose stream discharge.
- E. Seal penetrations between the control, cable spreading, and relay rooms with a 1-hour fire-rated, FM Approved fire-stop system. Conduct recorded inspections to confirm penetrations are properly sealed.

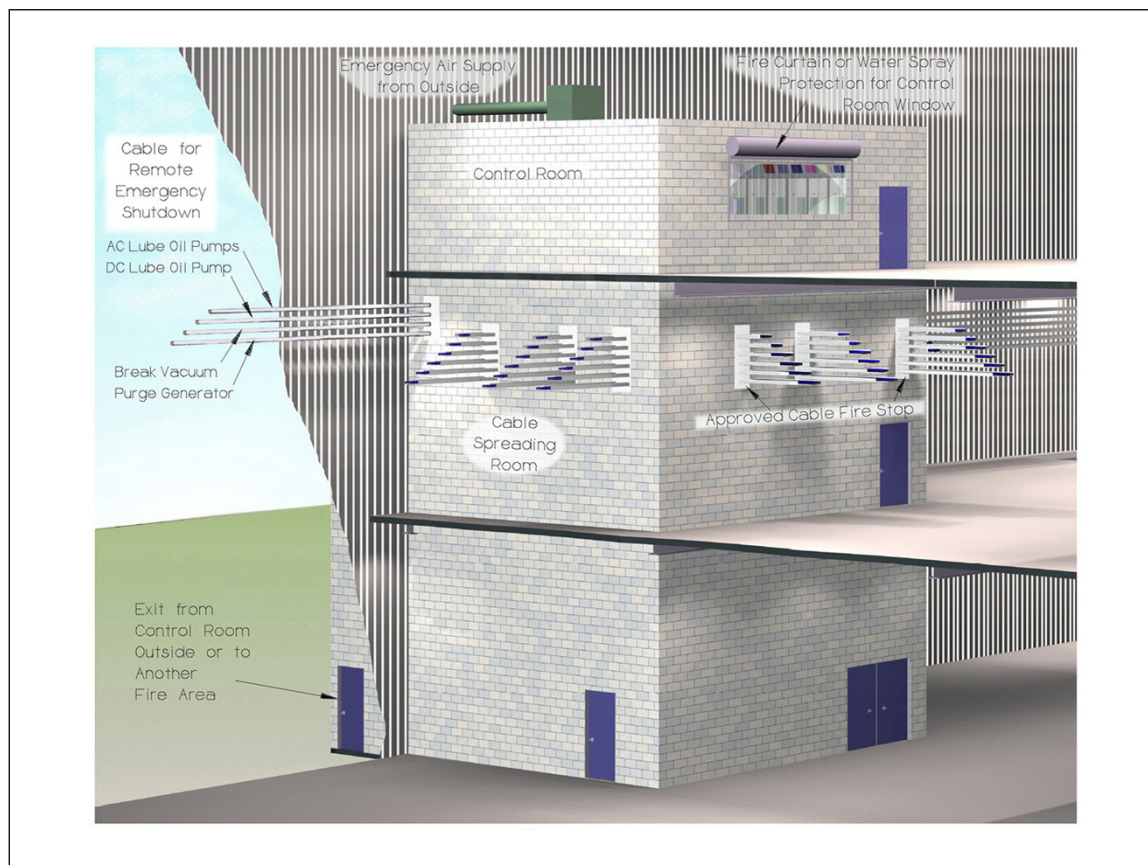

Fig. 7. Control room protection and protection of cable for remote turbine shutdown

F. Ensure equipment needed to safely shut down the turbine, such as solenoid valves to break vacuum and shutdown controls for the AC and DC lube-oil pumps, are arranged for remote operation from the control room.

2.2.8.3 The recommendations in Section 2.2.8.2 provide sufficient segregation and protection of the control room from a property protection standpoint. However, depending on the location and design of the control room, a facility may need to consider life safety issues, which are outside the scope of this data sheet. Where the control room is not designed to allow operators to remain and secure the turbines during a fire, arrange for emergency shutdown of the turbine and lube-oil pumps from a location that will be accessible.

2.2.8.4 Provide 1-hour fire-rated walls, floors, and ceilings for cable spreading and relay rooms.

2.3 Occupancy

2.3.1 Housekeeping

Maintain high standards of housekeeping in all areas.

2.3.1.1 Conduct periodic, recorded housekeeping inspections.

2.3.1.2 Provide a management reporting channel for prompt correction of housekeeping deficiencies.

2.3.1.3 Store flammable gas cylinders in a detached, dedicated area in accordance with Data Sheet 7-50, *Compressed Gases in Portable Cylinders and Bulk Storage*.

2.3.1.4 Store drums of lubricating or hydraulic oils outside the turbine enclosure and turbine building, or in a cutoff room located and constructed in accordance with Data Sheet 7-29, *Ignitable Liquid Storage in Portable Containers*.

2.3.1.5 Provide FM Approved cabinets for small containers of ignitable liquids.

2.3.2 FM Approved Industrial Fluids

2.3.2.1 Use FM Approved hydraulic (industrial) fluid, rather than mineral oil, in the turbine control system. Consult the original equipment manufacturer (OEM) in selecting a suitable FM Approved fluid.

2.3.2.2 Refer to Data Sheet 7-98, *Hydraulic Fluids*, for additional information regarding the conversion of equipment from a mineral oil-based hydraulic fluid to an FM Approved fluids.

2.3.3 Hydrogen Supply for Electric Generator Cooling

2.3.3.1 Provide a system of emergency venting and purging of hydrogen-cooled generators that will be accessible during a fire. Initiate venting and purging of the system with operation of the emergency shutoff valve.

2.3.3.2 Monitor hydrogen gas make-up flow rates and purity, and establish procedures to promptly respond to any unexpected changes.

2.3.4 Protective Equipment

2.3.4.1 Provide a condenser vacuum break system capable of being operated from the control room during a fire. To prevent damage to the turbine, ensure the unit is tripped before the vacuum break system is used.

2.3.4.2 Provide appropriate breather vents and emergency vents for clean and dirty oil tanks in accordance with Data Sheet 7-88, *Ignitable Liquid Storage Tanks*.

2.3.4.3 Provide vapor extractors in accordance with the original equipment manufacturer's (OEM) specifications for steam turbine oil reservoirs and hydrogen seal-oil reservoirs to remove non-condensable vapors.

2.3.4.4 Vent the lube-oil reservoir, vapor extractors, generator hydrogen-dump valve, and hydrogen detrainment tanks to outdoors.

2.3.4.5 Provide the capability to shut down the isolated phase bus ventilation system in the event of a fire involving a main or auxiliary transformer exposing the bus duct. This may be accomplished remotely from the control room, or from an area that would be accessible in the event of fire on the transformer.

2.3.5 Grouped Cables and Cable Spreading Rooms

Arrange cable trays as follows:

A. Locate and arrange grouped cables in accordance with Data Sheet 5-31, *Cables and Bus Bars*. Provide a minimum vertical separation of 18 in. (46 cm) between stacked cable trays.

B. Locate cable trays so as to avoid or reduce exposures from oil piping as far as practical. Where separation is not possible, locate trays above adjacent oil piping and away from potential three-dimensional spill fires so trays do not provide channels to spread burning oil.

C. Locate power cables above trays containing control and instrumentation cables.

D. Seal openings in floors, walls, and ceilings through which cables and piping pass from one fire area to another with an FM Approved fire-stop of 1-hour fire resistance. Pay special attention to penetrations into the control room, relay room, and cable spreading room.

E. Keep combustible material out of cable trays. Use covers to protect exposed cable trays where accumulation of combustible material is possible.

F. Provide a fire-resistive barrier below the bottom tray where cable trays are exposed from oil fires below. This barrier, in addition to automatic sprinkler protection, will limit fire damage to cables.

2.3.6 Earthquake

In 500-year or less frequent earthquake zones, anchor electrical cabinets and storage racks in accordance with Data Sheet 1-11, *Fire Following Earthquake*.

2.4 Protection

2.4.1 General

2.4.1.1 Provide a reliable, dedicated fire protection water supply of minimum 2-hour duration for the maximum design sprinkler discharge flow rate, as determined in Sections 2.4.2, 2.4.3, and/or 2.4.4, plus simultaneous discharge of any structural steel protection determined to be necessary (refer to Section 2.2.2) and 750 gpm (2,840 L/min) for hose streams.

2.4.1.2 Design systems to provide the recommended density over the most hydraulically remote demand area as described in Sections 2.4.2 and 2.4.3, and Figures 8a to 8h.

2.4.1.3 Install automatic sprinklers in accordance with Data Sheet 2-0, *Installation Guidelines for Automatic Sprinklers*. Install automatic water-spray systems in accordance with Data Sheet 4-1N, *Water Spray Fixed Systems, for Fire Protection*. Install foam-water sprinkler systems in accordance with Data Sheet 4-12, *Foam-Water Sprinkler Systems*. Install water mist systems in accordance with Data Sheet 4-2, *Water Mist Systems*.

2.4.1.4 Use a wet, preaction, or deluge system.

2.4.1.5 Provide standard response, high-temperature-rated automatic sprinklers if sprinklers are located under a solid deck or ceiling. The temperature rating of automatic sprinklers below grated floors and mezzanines is not critical.

2.4.1.6 Where the distance between the floor and the sprinklers is less than 15 ft (4.5 m), use a minimum K-factor of 8.0 (115). Where this distance is greater than or equal to 15 ft (4.5 m), use a minimum K-factor of 11.2 (161).

2.4.1.7 Arrange sprinklers on a maximum 100 ft² (9 m²) spacing.

2.4.1.8 Arrange sprinklers with a maximum on-line spacing of 10 ft (3.0 m). A variation of ±1 ft (0.3 m) is acceptable on either dimension to avoid obstructions by structural elements.

2.4.1.9 Where K 25 EC (363 EC) pendent or upright sprinklers are used, install only at the maximum approved spacing, as listed in Data Sheet 2-0, *Installation Guidelines for Automatic Sprinklers*. At this spacing, treat as a standard response sprinkler.

2.4.1.10 Provide FM Approved fire pumps, controllers and drivers as applicable. Install the equipment in accordance with recommendations in Data Sheet 3-7, *Fire Protection Pumps*. If electric motor-driven pumps are used, have power supplied from a source that will not be interrupted in the event of loss of power to the facility.

2.4.1.11 Arrange fire protection equipment located in areas exposed by earthquakes in accordance with Data Sheet 2-8, *Earthquake Protection for Water-Based Fire Protection Systems*.

2.4.1.12 Prevent water from impinging on emergency stop valves, combined reheat intercept valves, and governor (control) valves by either of the following methods:

- A. Properly locate and orient automatic sprinkler or water spray nozzles.
- B. Provide shields to prevent water impingement

2.4.1.13 Locate automatic deluge and preaction valves and water spray control valves where they can be manually operated from a safe, easily accessible location during a fire.

2.4.1.14 Space detectors for interior deluge systems (either pilot sprinkler, electric, or pneumatic) as follows:

- A. Install pilot sprinklers on the same spacing as sprinklers.
- B. Install electric or pneumatic devices under smooth ceilings using the spacing requirements listed in the *Approval Guide* for the particular model, or as recommended in data sheets that cover the specific occupancy.

2.4.1.15 Space detectors for preaction systems (pilot sprinkler, electric, or pneumatic) as follows:

- A. Install electric or pneumatic detectors at a spacing of one-half the listed linear detector spacing, or the full sprinkler spacing, whichever is greater (e.g., if a detector is FM Approved for 30 ft by 30 ft [9.1 m by 9.1 m] and allowable sprinkler spacing is 100 ft² [9 m²], then maximum allowable linear detector

spacing is 15 ft by 15 ft [4.6 m by 4.6 m]). For design purposes, treat preaction systems with this detector spacing the same as wet systems.

1. If a preaction system has a detector spacing greater than the above spacing, consider it a deluge system for design purposes. Refer to the *Approval Guide* for the maximum allowable spacing.

B. Install pilot sprinklers on the same spacing as the sprinklers. For design purposes, treat preaction sprinkler systems that use pilot sprinklers the same as dry systems, regardless of detector spacing.

2.4.1.16 Transmit fire alarm, water flow alarms, and pump supervisory signals to an alarm panel in the control room.

2.4.1.17 Provide portable extinguishing equipment as follows:

A. Standpipes in basement, ground floor, and operating floor areas such that all areas can be reached by at least one hose stream.

B. Wheeled, dry chemical and carbon dioxide extinguishers on the operating floor for small fires at bearings.

2.4.2 Fire Protection for Oil Spray Fires

2.4.2.1 Provide one of the following protection methods over oil pumps and conditioning equipment where pressurized releases could result in spray fires that could expose the roof, operating floor, turbine, generator, or other critical targets:

A. Provide a room or enclosure around the equipment and spray source in accordance with Section 2.2.4.2. Protect the interior of the enclosure in accordance with Section 2.4.5.

B. Provide a combination of barriers and sprinklers, designed as follows:

1. Install a heavy gauge metal (e.g., 12 gauge [2 mm]) spray hood or barrier above the spray fire source. Provide additional barriers where sprays can expose important equipment (see item 1 in Figure 8). Support the barrier on the unexposed side.

2. Provide a wet or deluge sprinkler system under the barrier on a maximum 10 x 10 ft (3.0 x 3.0 m) spacing. Do not support the sprinkler piping from the hood.

3. Use a K-factor of 8.0 (115), and design the sprinklers to provide a minimum end pressure of 50 psig (3.4 barg).

4. Extend the protection at least 5 ft (1.5 m) beyond each spray source.

C. Provide closely spaced sprinklers above the spray source, designed as follows:

1. Install a deluge sprinkler system over each leak point (see item 2 in Figure 8).

2. Install pendent sprinklers with a K-factor of 8.0 (115), and provide a minimum end pressure of 50 psig (3.4 barg).

3. Locate sprinklers with approximately 6 ft (1.8 m) vertical clearance above the potential oil spray source.

4. Provide a minimum of nine sprinklers on 5 x 5 ft (1.5 x 1.5 m) spacing. Extend the protection at least 5 ft (1.5 m) beyond each spray source.

5. Activate deluge systems automatically using either an FM Approved flame detection system or an FM Approved line-type heat detection, with the line-type detection installed around sprinkler piping to ensure that a spray fire will activate the system.

D. Use FM Approved spray fire shields on flanges of piping containing pressurized mineral oil or industrial fluids that are not FM Approved. The use of an FM Approved spray fire shield does not eliminate the need for fire protection, but reduces the fire hazard from a spray fire to a localized pool and spill fire that can be protected in accordance with Section 2.4.3.

E. Provide water mist systems FM Approved for "Spray Fire – Point Protection" and arranged in accordance with Section 2.4.6.

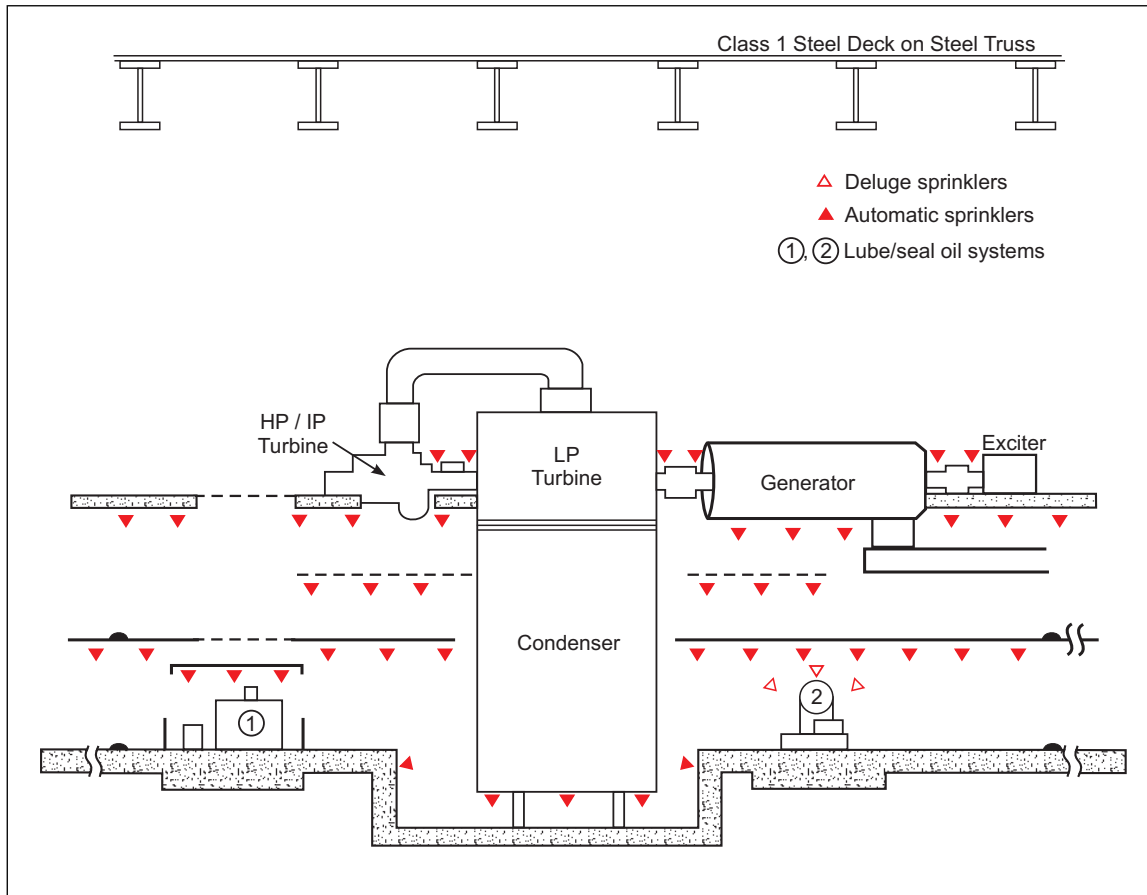

Fig. 8. Protection for medium size turbine generator with floor openings near mineral oil systems needing spray fire protection

2.4.3 Fire Protection from Pool and Three-Dimensional Spill Fires

The protection used depends on whether the operating floor is a solid operating floor or island-type, whether there are intermediate floors, and whether the intermediate floors are solid or grated.

Provide automatic sprinkler protection under the operating floor. In addition, provide automatic sprinkler protection for all intermediate floor levels for pool oil fire protection over systems containing mineral oil, containment areas, and all areas to which oil can flow, including under generator, condenser pits, and areas between concrete pedestals. Extend the protection at least 20 ft (6 m) in all directions beyond the pool fire hazard.

2.4.3.1 Solid Operating Floor with no Mezzanine(s)

2.4.3.1.1 Provide the following protection under solid operating floors with no mezzanine(s) (see Figure 9a).

- A. Provide an automatic sprinkler system with the density recommended in Table 1 over a demand area of 5,000 ft² (465 m²).
- B. The following optional protection scheme may be used (see Figure 9b).
 - 1. Install automatic sprinkler protection below the operating floor at a density of 0.3 gpm/ft² (12 mm/min) over a demand area of 5,000 ft² (465 m²).
 - 2. Install an intermediate level of automatic sprinkler protection over the pool fire hazard. Use the density recommended in Table 1 over a demand area of 2,500 ft² (232 m²) or the limits of containment, whichever is less.

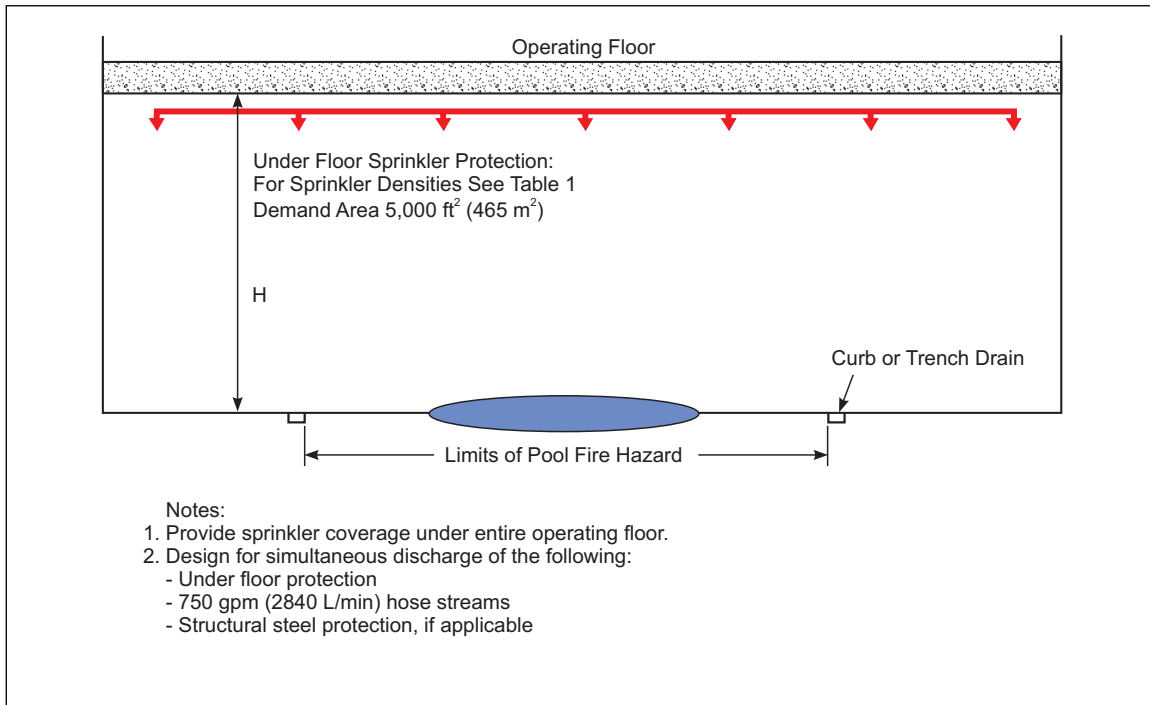

Fig. 9a. Protection for turbine buildings with solid operating floors

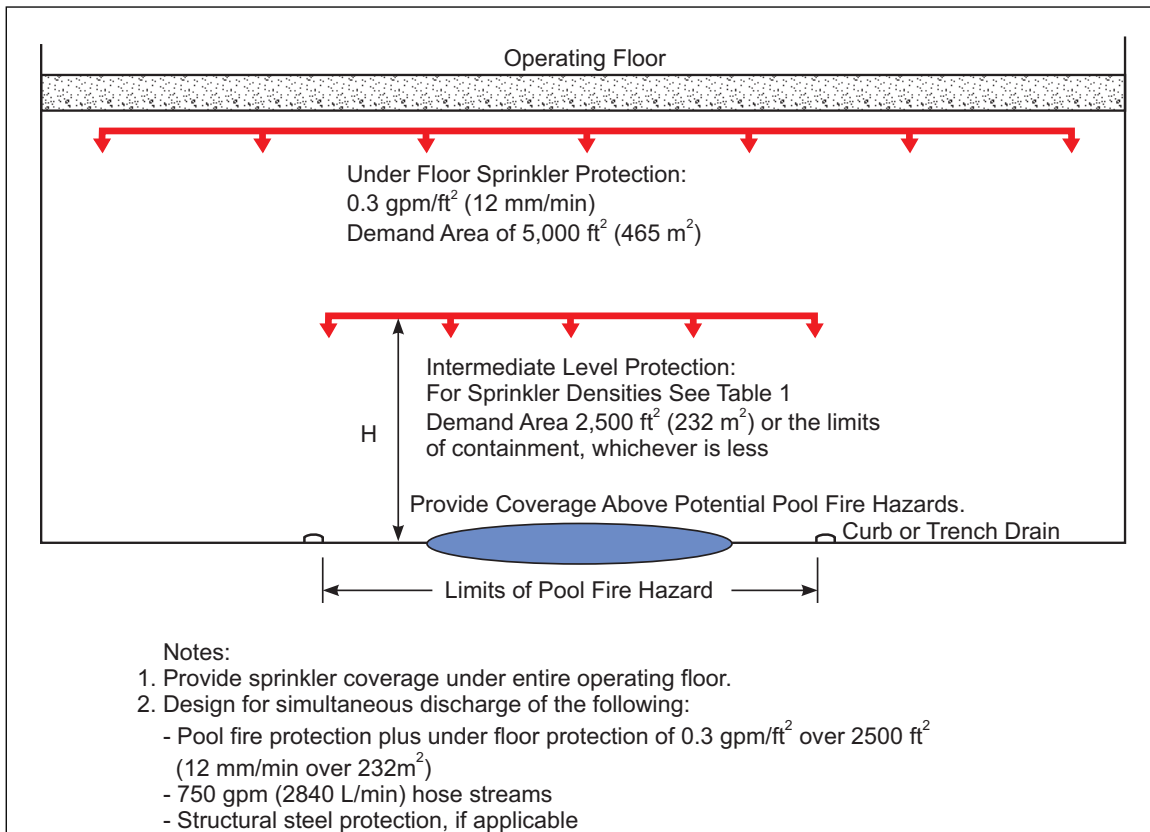

Fig. 9b. Optional protection for turbine buildings with solid operating floors higher than 30 ft (9.1 m)

3. Additionally, design for simultaneous discharge of intermediate-level protection plus under-floor protection at 0.3 gpm/ft² (12 mm/min) over 2,500 ft² (232 m²).

Table 1. Sprinkler Densities for Pool Oil Fires

Height (H) of Sprinklers Above Pool ft (m)	Water Density gpm/ft ² (mm/min)
H = 15 (4.6)	0.3 (12)
15 (4.6 m) < H ≤ 30 (9.1)	0.4 (16)
30 (9.1) < H ≤ 40 (12.0)	0.7 (29)
40 (12.0) < H ≤ 45 (13.8)	0.8 (33)
45 (13.8) < H ≤ 60 (18.5)	1.6 (64)

2.4.3.1.2 Where foam-water sprinklers or compressed air foam (CAF) are used to supplement automatic sprinkler protection or as an alternative to providing an emergency drainage system, use the following design criteria:

- A. Install the system in accordance with the manufacturer’s instruction, the FM Approval listing, and Data Sheet 4-12, *Foam-Water Sprinkler Systems*.
- B. Where a foam-water sprinkler system is installed, hydraulically design the system in accordance with the sprinkler density recommended in this data sheet or the FM Approval listing density, whichever is larger, over the full demand area.
- C. Where a CAF system is installed, design the CAF system in accordance with the manufacturer’s instructions and the system’s listing in the *Approval Guide*, and design the sprinkler system in accordance with the sprinkler density recommended in this data sheet.
- D. Design the foam concentrate supply and air supply, if applicable, to provide the full sprinkler discharge (use actual discharge based on water supply) plus any hose streams also arranged to provide foam discharge for the greater of:
 - 1. 20 minutes.
 - 2. the maximum projected time needed to achieve a safe shutdown of the lube-oil system following emergency trip of the turbine, plus 10 minutes. Determine maximum safe shutdown time based on the emergency shutdown procedure (see Section 2.5.2).
- E. Include an exterior hose stream allowance of 750 gpm (2,840 L/min).
- F. Provide containment as recommended in this data sheet.

2.4.3.2 Solid Operating Floor with Grated Mezzanine(s)

2.4.3.2.1 Provide the following protection where there is a grated mezzanine below the operating floor:

- A. Provide a density of 0.30 gpm/ft² (12 mm/min) over 5,000 ft² (465 m²) below the operating floor.
- B. Provide protection below the grated mezzanine using the automatic sprinkler density specified in Table 1 over 2,500 ft² (232 m²) or the limits of containment, whichever is less.
- C. Where there are two levels of grated mezzanines (see Figure 9c) do the following:
 - 1. Provide a design density of 0.30 gpm/ft² (12 mm/min) over 1,500 ft² (140 m²) below the intermediate mezzanine.
 - 2. Provide protection below the lower level mezzanine using densities given in Table 1 over an operating area of 2,500 ft² (232 m²) or the limits of containment, whichever is less.
- D. Design for simultaneous discharge of below-mezzanine protection plus under-floor protection at the required density over 2,500 ft² (232 m²). If an intermediate, grated floor is provided, include the 0.3 gpm/ft² (12 mm/min) over 1,500 ft² (140 m²).

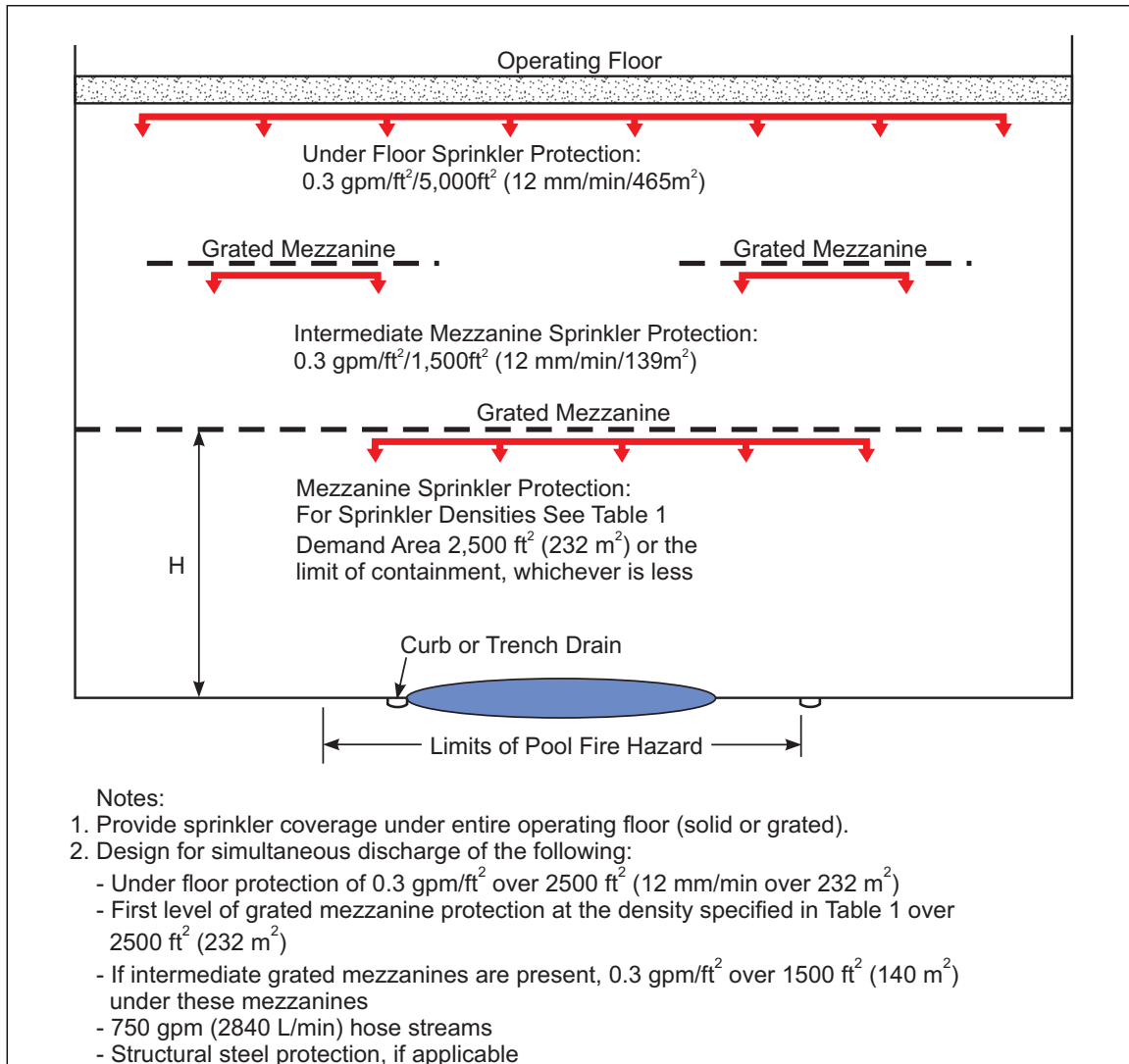

Fig. 9c. Protection for turbine buildings with solid operating floor and grated mezzanines below

2.4.3.2.2 Where a foam-water or compressed air foam (CAF) system is used to supplement automatic sprinkler protection or as an alternative to providing an emergency drainage system, design the system in accordance with Section 2.4.3.1.2.

2.4.3.3 Solid Operating Floor with Solid Mezzanine(s)

2.4.3.3.1 Provide the following protection where there is a solid mezzanine below the operating floor:

A. Provide the following densities below the operating floor:

1. Provide a density of 0.30 gpm/ft² (12 mm/min) over a demand area of 5,000 ft² (465 m²) where no hold-up of oil is expected on the mezzanine.
2. Provide the density specified in Table 1 over a demand area of 5,000 ft² (465 m²) when hold-up of oil is expected on the mezzanine.

B. Provide the following below the solid floor mezzanine:

1. Provide the density specified in Table 1 over a demand area of 5,000 ft² (465 m²) (see Figure 9d), or

2. Where the mezzanine height is greater than that shown in Table 1, install automatic sprinkler protection below the mezzanine at a density of 0.3 gpm/ft² (12 mm/min) over a demand area of 5,000 ft² (465 m²) with an intermediate-level of automatic sprinkler protection over the pool fire hazard. For this intermediate-level of protection, use the density recommended in Table 1 over a demand area of 2,500 ft² (232 m²) or the limits of containment, whichever is less.

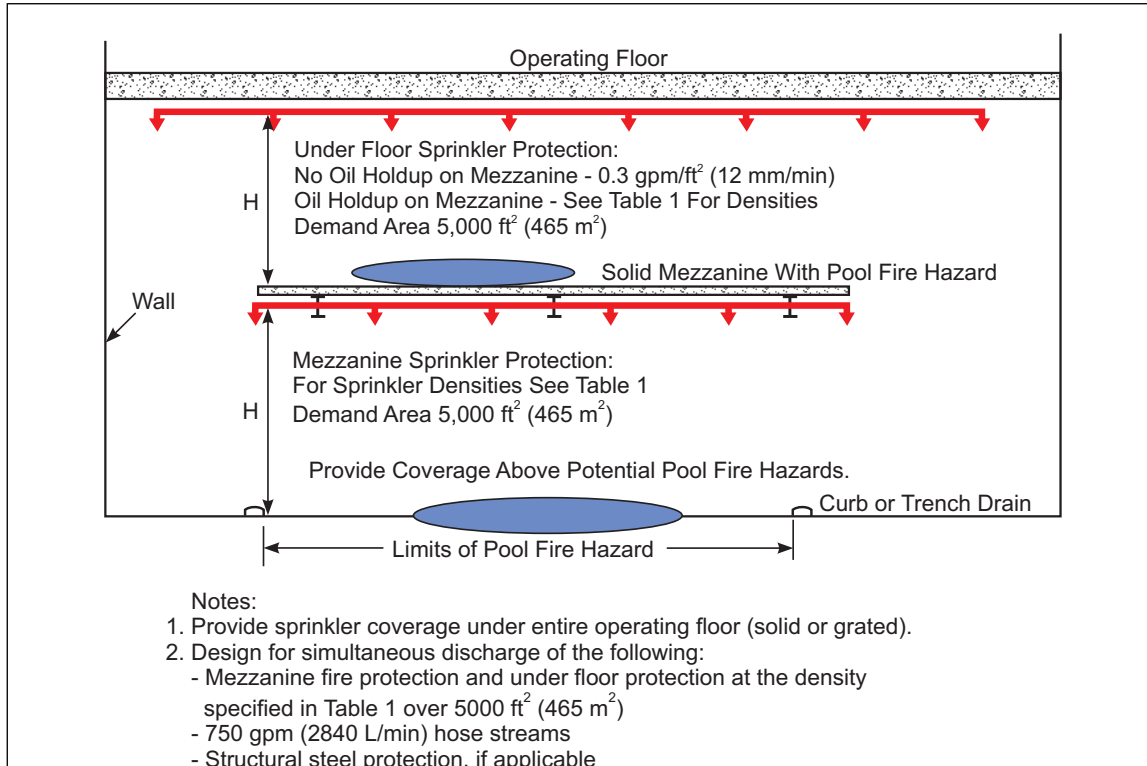

Fig. 9d. Protection for turbine buildings with solid operating floor and solid floor mezzanines

C. Design for simultaneous discharge at the required density over 5,000 ft² (465 m²) both below the mezzanine and below the operating floor.

2.4.3.3.2 Where a foam-water sprinkler or compressed air foam (CAF) system is used to supplement the automatic sprinkler protection or as an alternative to providing an emergency drainage system, design the system in accordance with Section 2.4.3.1.2.

2.4.3.4 Island-Type Designs

2.4.3.4.1 For island-type operating floor designs, provide protection over systems containing mineral oil, containment areas, and all areas to which burning oil can flow, including under the generator, condenser pits, exciter, and areas between concrete pedestals. For high-bay noncombustible roofs, where the height of the roof above the ground level is greater than 30 ft (9.1 m), provide protection under the operating floor and over specific oil hazards (Figure 2, Figure 9e). For low-bay noncombustible roofs, where the height of the roof above the ground level is less than or equal to 30 ft (9.1 m), provide protection at roof level and below major obstructions such as the operating floor (Figure 9f).

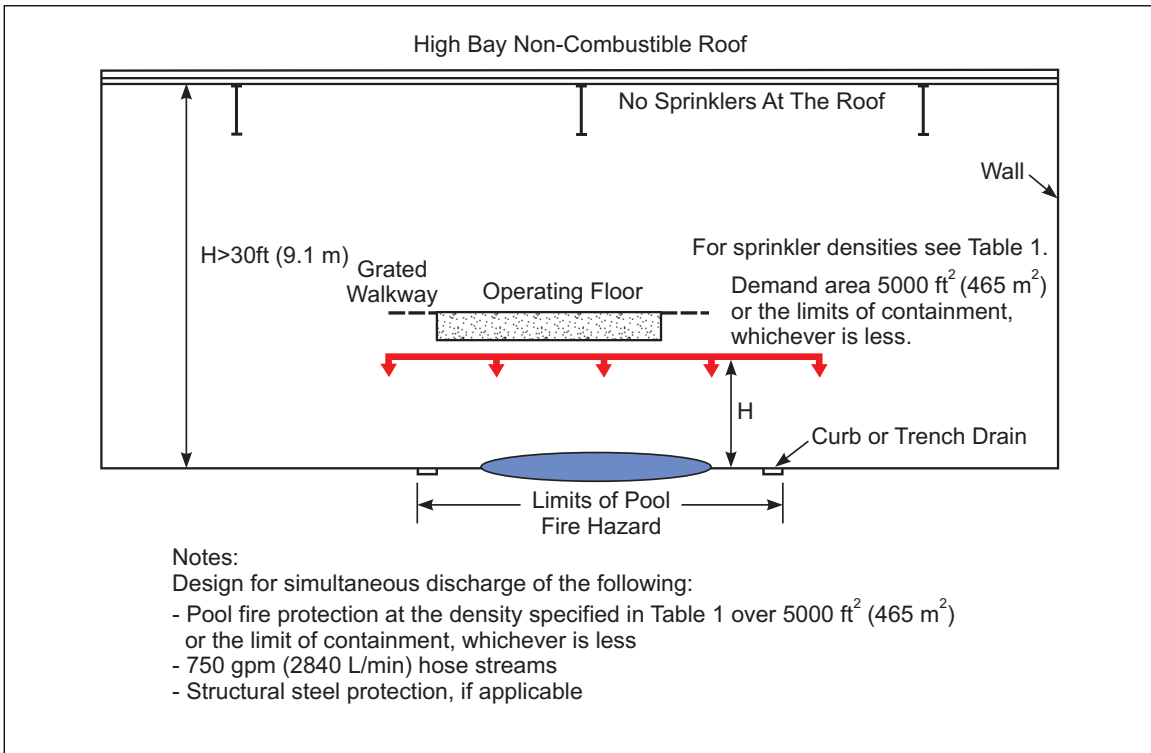

Fig. 9e. Local protection for island type turbine buildings

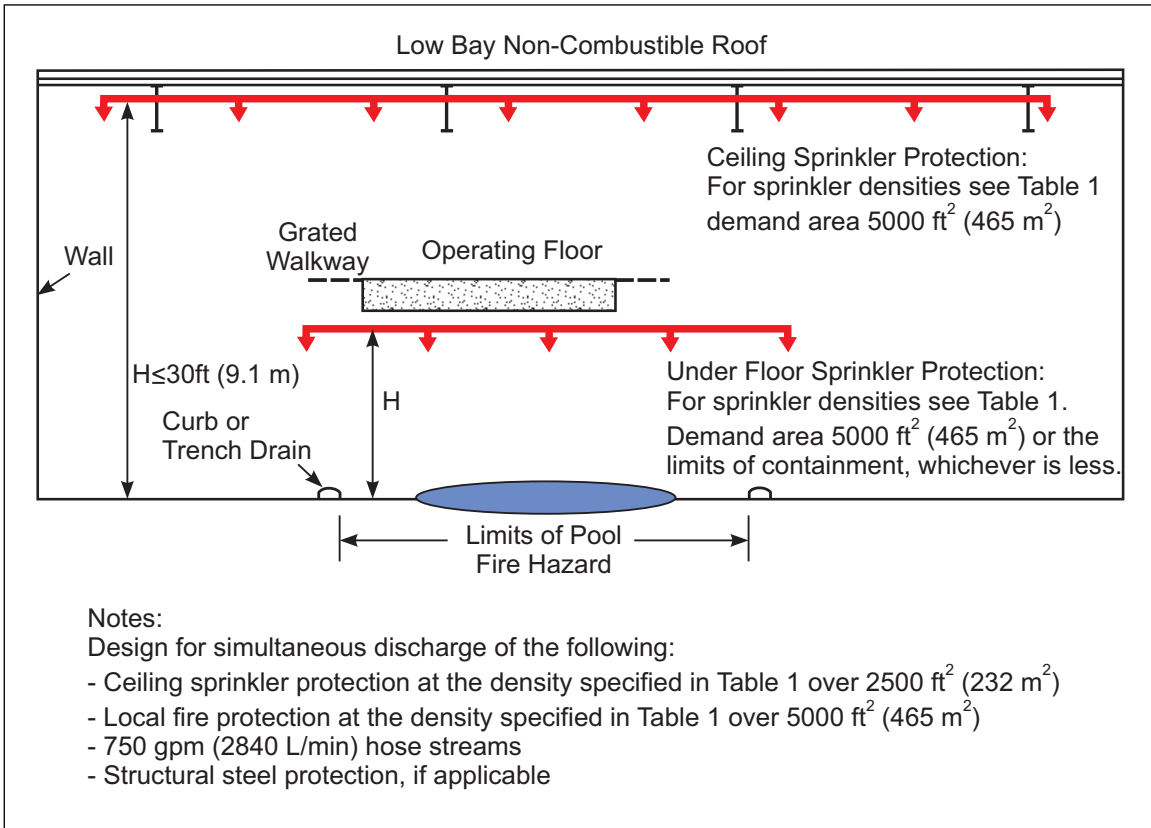

Fig. 9f. Protection for island-type turbine buildings with roof height within Table 1 or less

A. Based on the height of the sprinklers above the pool fire hazard, provide the sprinkler density specified in Table 1.

B. Design roof level sprinklers for a demand area of 5,000 ft² (465 m²). Design local sprinklers for a demand area of 5000 ft² (465 m²) or the limits of the containment, whichever is less.

C. Where both roof-level and local sprinklers are provided, design for simultaneous discharge of roof-level protection at the required density over 2500 ft² (232 m²), and local protection at the required density over 5000 ft² (465 m²).

2.4.3.4.2 Where a foam-water sprinkler or compressed air foam (CAF) system is used to supplement automatic sprinkler protection or as an alternative to providing an emergency drainage system, design the system in accordance with Section 2.4.3.1.2.

2.4.3.5 Solid Pedestal Designs

2.4.3.5.1 Provide the following protection for solid pedestal designs where it is not possible for oil to flow below the operating floor.

A. For high-bay noncombustible roofs, where the height of the roof above the ground level is greater than 30 ft (9.1 m), provide protection over specific oil hazards and areas adjacent to the turbine generator where oil can flow (Figure 9g). For low-bay noncombustible roofs, where the height of the roof above the ground level is less than or equal to 30 ft (9.1 m), provide protection at roof level and locally over major oil hazards (Figure 9h).

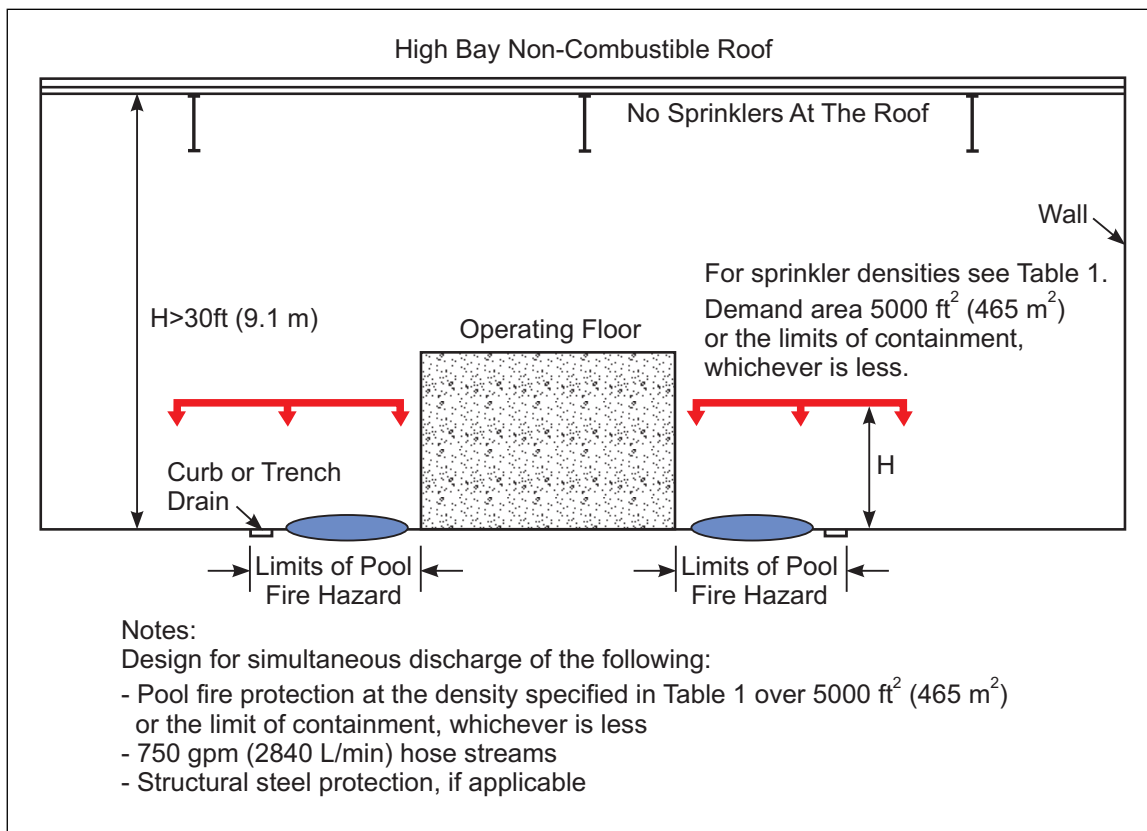

Fig. 9g. Local protection for solid pedestal designs

B. Based on the height of the sprinklers above the pool fire hazard, provide the sprinkler density specified in Table 1.

C. Design roof-level sprinklers for a demand area of 5,000 ft² (465 m²). Design local sprinklers for a demand area of 5000 ft² (465 m²) or the limits of the containment, whichever is less.

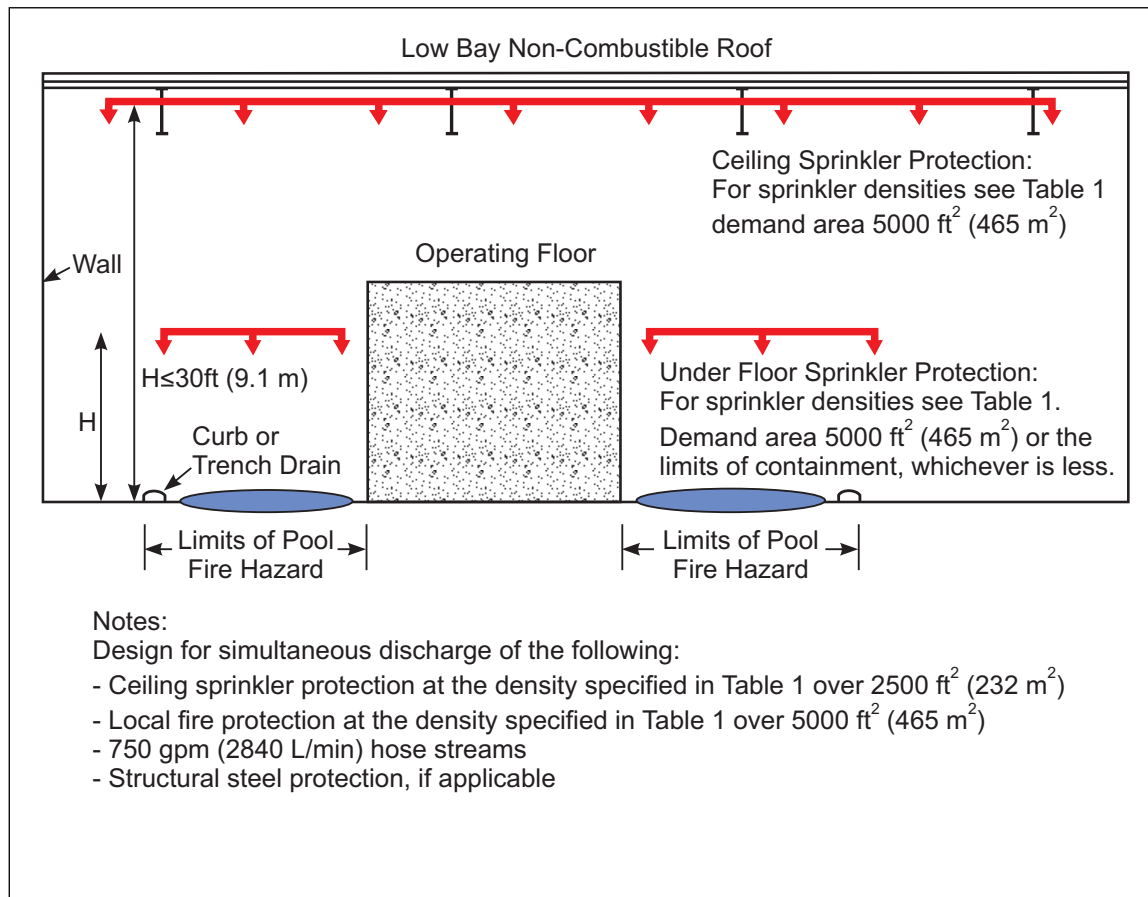

Fig. 9h. Protection for solid pedestal designs with roof height within Table 1 or less

D. Where both roof-level and local sprinklers are provided, design for simultaneous discharge of roof-level protection at the required density over 2500 ft² (232 m²), and local protection at the required density over 5000 ft² (465 m²).

2.4.3.4.2 Where a foam-water sprinkler or compressed air foam (CAF) system is used to supplement automatic sprinkler protection or as an alternative to providing an emergency drainage system, design the system in accordance with Section 2.4.3.1.2.

2.4.4 Protection on Operating Floors

2.4.4.1 Provide a fixed, FM Approved, automatically actuated water-spray system with directional-spray nozzles or automatic sprinkler protection flowing 30 gpm (113 L/min) per nozzle. Include the maximum number of nozzles expected to operate in any single fire event in the system design. Ensure the temperature rating prevents accidental operation. Provide protection for the following systems containing mineral oil:

- The seal area and lube-oil pipe connections to bearing housings. This includes the outboard bearing if it is outside the exciter enclosure. Although the specific design of the bearing protection will vary depending on the nozzle manufacturer, nozzles will usually be located approximately 2 ft (0.6 m) above each bearing at the 10 o'clock and 2 o'clock positions, as shown in Figure 10. Refer to Section 2.4.4.3 for the protection of exciter enclosures.
- Control-oil systems with threaded or flanged fittings.
- Main supply and return oil piping with threaded or flanged fittings.
- Under-turbine skirts (appearance lagging) where oil piping is located (See Figure 9)
- Oil supply and return branch lines when:

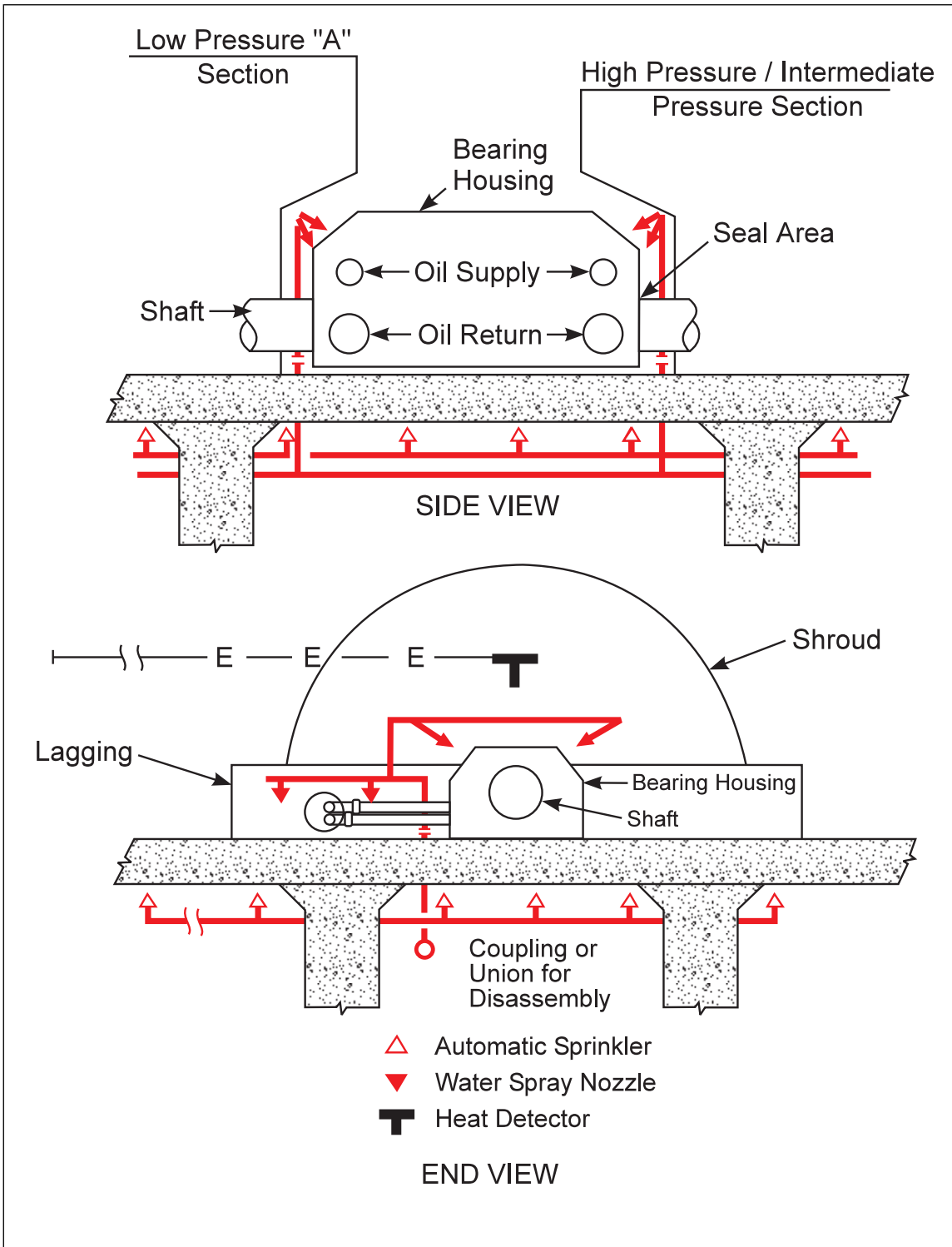

Fig. 10. Protection for bearing housing and areas under turbine skirts

1. they contain sight glasses or monitoring devices that can be damaged by heat from a fire, or
2. they are flanged and bolted above the operating floor at locations other than the bearing housing.

2.4.4.2 Provide drainage or a local protection system where oil could accumulate on the operating floor as the result of containment areas formed by curbs, kick-plates, etc. If a local protection system is provided, ensure density is 0.3 gpm/ft² (12 mm/min) over the containment area.

2.4.4.3 Protect the area inside a directly connected exciter housing with a total flooding automatic carbon dioxide system. Design the carbon dioxide system in accordance with Section 2.4.5.

2.4.5 Enclosed Steam Turbines or Generators

2.4.5.1 If the turbine or generator is located in a cutoff room or similar enclosed space, provide one of the following forms of protection:

- A. An automatic sprinkler system designed in accordance with Section 2.4.1.
- B. An FM Approved inert gas or carbon dioxide (CO₂) system.
- C. A total flooding water mist system FM Approved for the protection of turbines or machinery in enclosures, as applicable.
- D. A hybrid (water and inert gas) system FM Approved for the protection of turbines or machinery in enclosures, as applicable.

2.4.5.2 If a special extinguishing system is used to protect an enclosed steam turbine, generator, or exciter compartment, design, install, test, and accept the system in accordance with Data Sheet 7-79, Fire Protection for Gas Turbines and Electric Generators.

2.4.6 Water Mist Systems for Oil Fire Hazards in Unenclosed Areas

2.4.6.1 An FM Approved local application water mist system is acceptable as an alternative to local application water spray systems or sprinkler systems over specific oil fire hazard areas, including spray fire, pool fire, and combination spray/pool fire hazards as defined by the oil fire hazard assessment. Local application water mist systems are not applicable to 3D spill fire hazard scenarios.

2.4.6.2 Install the local application water mist system in accordance with Data Sheet 4-2 and the manufacturer's FM Approved Design, Installation, Operation, and Maintenance (DIOM) manual.

2.4.6.2.1 Arrange the water mist nozzles to surround the expected oil pool fire hazard footprint or spray fire source in accordance with the manufacturer's FM Approved layout. Figure 2.4.6.2.1 shows a typical layout.

2.4.6.3 Use water mist systems FM Approved for the "Combination 2D Ignitable Liquid Pool Fire & Spray Fire Protection" application type from the Local Application Protection category. It is expected that areas with potential spray fires will also have pool fire potential. Water mist systems need to be laid out to address both hazards.

2.4.6.3.1 Surround the oil containment area with water mist nozzles in accordance with the manufacturer's FM Approved (DIOM) manual.

2.4.6.4 It is acceptable to use a water mist system FM Approved for "Spray Fire - Point Protection" where there is a spray fire hazard as long as the system is supplemented by water mist protection to protect the pool fire hazard.

2.4.6.4.1 Direct water mist nozzles at the spray fire release point in accordance with the manufacturer's FM Approved DIOM manual.

2.4.6.5 It is acceptable to use a water mist system FM Approved for "2D Ignitable Liquids Channel Protection" for drainage channels provided it covers the entire length of the channel.

2.4.6.5.1 Where oil is directed through drainage channels to a secondary containment area, surround the release and containment areas with water mist nozzles in accordance with the manufacturer's FM Approved DIOM manual.

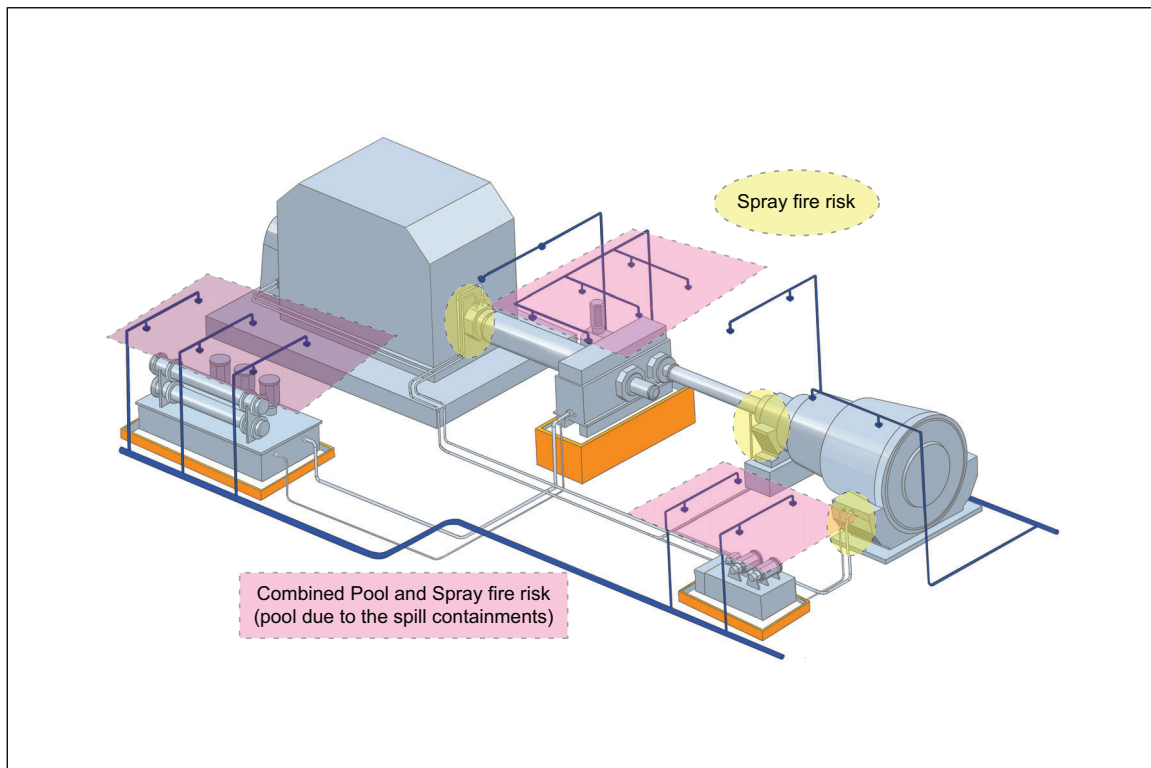

Fig. 2.4.6.2.1. Typical layout of a water mist system for local application over oil fire hazards (NOTE: Shaded areas are not solid barriers, but areas of operation.)

2.4.6.6 Provide drainage and containment in accordance with Section 2.2.3. Applications in which the oil flow path is not controlled, such as flow below the level of the oil release point or where there are numerous leak points (i.e., flanged piping connections spread out in a large volume), are not suitable to being protected by these systems.

2.4.6.7 Provide a water supply capable of supplying the full design flow of the water mist system for the duration of the oil release event, but not less than 1 hour.

2.4.6.8 Provide a water supply capable of supplying a 500 gpm (1900 L/min) hose stream allowance for the duration of the oil release event but not less than 1 hour. It is acceptable to source the hose stream allowance from a water supply separate from the water mist system's.

2.4.6.9 Provide a fire detection system (i.e., heat detector, flame detector, or video detector) arranged to ensure prompt detection of a fire and installed in accordance with Data Sheet 5-48, *Automatic Fire Detection*, and in accordance with the applicable Approval listing.

2.4.6.9.1 For ceiling heights up to 60 ft (18 m), install ordinary temperature spot or linear heat detectors in accordance with the following:

- A. Space heat detectors located below solid barriers or ceilings up to 30 ft (9 m) above the fire hazard in accordance with the manufacturer's FM Approved spacing.
- B. Space heat detectors located below solid barriers or ceilings between 30 ft (9 m) and 60 ft (18 m) above the fire hazard at not more than 10 ft x 10 ft spacing (3 m x 3 m).

2.4.6.9.2 For ceiling heights greater than 60 ft (18 m) or where the ceiling is obstructed by piping or equipment, provide local area heat detection or flame/video detectors in accordance with the following:

- A. Provide intermediate heat detector(s) within 10 ft (3 m) above the fire hazard. Place the detectors near potential leak points. Provide at least two detectors near each potential leak point with a linear horizontal spacing between detectors of no more than 4 ft (1.2 m).

B. Locate flame or video detectors in positions that provide a clear line of sight to the fire hazard. Flame or video detectors must be FM Approved for use with the fuels expected to be involved in the fire.

2.4.7 Combustible Roof Protection

Provide one of the following protection methods for buildings with combustible roof construction, including Class 2 steel deck:

- A. Replace the combustible roof with a noncombustible roof.
- B. Install automatic sprinkler protection at roof level. Provide water demand for ceiling protection in accordance with the criteria in Table 2.

Table 2. Ceiling Sprinkler Design Criteria for Turbine Buildings with Combustible Roof Construction

Type of Sprinkler System	Sprinkler Temperature Rating	Density gpm/ft ² (mm/min)	Area of Demand ft ² (m ²)
Wet	High	0.20 (8)	5000 (465)
Dry			8000 (740)
Hose stream demand: 750 gpm (2840 l/min) Duration: 60 min (water supply duration may need to be increased when conditions exist that could delay manual firefighting efforts.)			

2.4.8 Outdoor Units

2.4.8.1. Protect the area below the operating floor and intermediate floors in accordance with the recommendations in Sections 2.4.2 and 2.4.3.

2.4.8.2. Install automatic sprinkler protection around the perimeter of the ground floor elevation where an external fire exposure could occur. Install one branch line of automatic sprinklers on 8 ft (2.4 m) centers.

2.4.8.3 Protect the installed sprinkler system against potential freeze damage in accordance with Data Sheet 2-0, *Installation Guidelines for Automatic Sprinklers*.

2.4.9 Boiler Feed Pumps, Turbine and Electric Drivers, and Variable Speed Couplings

2.4.9.1 Provide a fixed, automatically actuated water-spray system with directional spray nozzles or automatic sprinkler protection flowing 30 gpm (113 L/min) per sprinkler over the oil systems for boiler feed pump drivers and variable speed couplings containing more than 100 gal (380 L) of oil.

2.4.9.2 Protect floor areas below boiler feed pump, driver, and variable speed coupling oil systems where failure of piping could result in the release of more than 100 gal (380 L) of oil. Extend protection to include areas above and 20 ft (6.1 m) beyond where oil can flow.

2.4.9.3 Evaluate whether an oil fire would expose high-value or critical equipment. Provide containment and local protection, or shield temperature-sensitive equipment where smaller quantities of oil (less than 100 gal [380 L]) are involved.

2.4.10 Relay and Cable Spreading Rooms and Transformers

2.4.10.1 Protect cable rooms and cable trays in accordance with Data Sheet 5-31, *Cables and Bus Bars*.

2.4.10.2 Protect transformers in accordance with Data Sheet 5-4, *Transformers*.

2.4.11 Control Rooms and Distributed Control System (DCS) Rooms

2.4.11.1 Provide detection and automatic sprinkler protection in control rooms and DCS rooms in accordance with Data Sheet 5-32, *Data Centers and Related Facilities*.

2.4.11.2 Protect subfloors in accordance with the recommendations in Data Sheet 5-32, *Data Centers and Related Facilities*.

2.5 Operation and Maintenance

Refer to Data Sheet 9-0, *Maintenance and Inspection*, for general recommendations regarding the establishment of maintenance and inspection programs for facilities equipment and systems.

2.5.1 Fire Prevention

2.5.1.1 Identify operation and maintenance activities where errors could result in the accidental release of oil, such as on-line maintenance work on lubrication-and-hydraulic oil systems. Include fire prevention warnings and precautions in the procedures for these activities.

2.5.1.2 Ensure equipment and devices that represent potential oil release sources are regularly maintained, inspected, and tested.

2.5.2 Emergency Shutdown Procedure

2.5.2.1 Provide an emergency shutdown system that will allow the turbine and associated fluids to be shut down promptly and safely in emergency situations.

2.5.2.2 Ensure equipment needed for emergency shutdown of the turbine, such as emergency turbine trip and shutdown controls for the AC and DC lube-oil pumps, is arranged for remote operation from the control room.

2.5.2.3 Label all emergency activation devices to assist operators during emergency response.

2.5.2.4 Develop a documented emergency shutdown procedure to help limit the extent of property damage and downtime in case of fire.

2.5.2.5 Establish a procedure, including shutdown of lubrication-oil systems and hydrogen systems, if shutdown is necessary, for each of the following scenarios:

- A. A fire that is controlled by fixed fire protection systems and/or the emergency response team (such as a minor leak or insulation blanket fire). In this case, based on an assessment of the fire event, hydrogen cooling may be left in service and shutdown of lubrication-oil systems may not be necessary.
- B. A single point release of oil and subsequent fire that is not controlled by either fixed protection or the emergency response team, resulting in the need to provide a controlled shutdown of all equipment, including oil systems.
- C. Mechanical damage to turbine generator equipment severe enough to stop the rotating element, with a subsequent fire.

2.5.2.6 With the assistance of the turbine manufacturer or a qualified equipment expert, document the proper sequencing and critical actions required to be taken by operators when they activate the emergency shutdown system. Ensure onsite personnel having documented authorization to implement the emergency shutdown procedure are available on all shifts.

2.5.3 Spray Fire Shield Inspection and Maintenance

Inspect and maintain all spray hoods, barriers, and spray fire shields as follows:

- A. Itemize, tag, and inspect the equipment on a monthly, recorded basis.
- B. Establish a supervision program and documentation system to ensure proper replacement of all spray hoods, barriers, and spray fire shields removed for maintenance activities. Use supervision equivalent to or included in the facility's lock-out, tag-out program.
- C. Provide periodic refresher training for maintenance and operations personnel on the intent and proper maintenance of spray hoods, barriers, and spray fire shields.

2.5.4 Oil Fire Hazards Assessment (OFHA)

An Oil Fire Hazards Assessment (OFHA) is a detailed, fire-focused engineering review of oil systems, potential release and fire scenarios, and the adequacy of provided safeguards.

2.5.4.1 Conduct a team-based OFHA. Involve key facility personnel in the review and evaluation of the fire protection safeguards.

2.5.4.2 Conduct an OFHA for each lubrication, seal, or control system that uses mineral oil or other ignitable liquids that are not FM Approved. See Section 3.1.5 for a description of the methodology and procedures for conducting these reviews.

2.5.4.3 Describe and document the following items by means of narrative and schematics:

- A. Oil system arrangement and operating details (pump capacities, pressure, and reservoir size)
- B. Emergency drainage and containment provisions
- C. Fixed fire protection system design criteria
- D. Emergency response plan
 - 1. Emergency shutdown procedure for oil systems
 - 2. Public fire service pre-planning

2.5.4.4 Determine oil release and fire scenarios based on the compiled equipment and building information.

2.5.4.5 Based on the scenarios, evaluate the adequacy of the provided safeguards and set up action items to make improvements where needed.

2.6 Training

2.6.1 Employee Training

2.6.1.1 Provide periodic refresher fire awareness and prevention training to operators and maintenance personnel.

2.6.1.2 Conduct regular training for all personnel designated to perform emergency shutdown functions. For example, the following training methods can be used:

- A. Simulator training
- B. Unannounced drills, where a fire scenario is given to the operators and they are asked to respond in accordance with the emergency shutdown plan. Operators are asked to describe appropriate actions in accordance with the emergency plan without actually taking action, such as pushing a button. Flaws may become apparent using this training method that would not show up in a written test.
- C. A written and/or oral exercise in which a problem is described and questions are asked regarding proper actions to take.

2.6.2 Contractor Training

2.6.2.1 Ensure contractors with access to turbine areas are trained in fire prevention methods, including facility hot work policy and procedures.

2.6.2.2 Train contractors to follow in-plant notification procedures for emergency situations.

2.7 Human Factor

See Data Sheet 10-0, *The Human Factors of Property Conservation*, for general recommendations and guidance.

2.7.1 Supervision of Programs

2.7.1.1 Designate qualified facility personnel to be responsible for implementing the loss prevention programs and activities associated with steam turbines and generators.

2.7.1.2 Provide the designated personnel with appropriate training, resources, and a management reporting procedure.

2.7.2 Supervision of Contractors

2.7.2.1 Establish a policy and programs to supervise outside contractors while they are at the facility.

2.7.2.2 Refer to Data Sheet 10-4, *Contractor Management*, for guidance on developing an effective program to manage contractors.

2.7.3 Plant Inspections

2.7.3.1 Conduct regular, recorded inspections of all oil systems to detect and repair leakage.

2.7.3.2 Periodically inspect all fire protection equipment in accordance with Data Sheet 2-81, *Fire Protection System Inspection, Testing and Maintenance*.

2.7.4 Emergency Response and Pre-Incident Planning

Design the facility's emergency response plan to address potential worst-case fire scenarios as established in the Oil Fire Hazards Assessment (see Section 2.5.4). Refer to Data Sheet 10-1, *Pre-Incident Planning*, for general guidelines on establishing and maintaining an emergency response plan.

2.7.4.1 Arrange and prepare documented procedures to expedite safe entry and emergency response to situations such as fires and explosions in turbine areas, including the following:

- A. Manual emergency trip of the turbine
- B. Notification of facility management and the emergency response team; include names and current contact information
- C. Organizational responsibility for managing emergency response
- D. Information on when to break condenser vacuum following unit trip to reduce the rundown time of the turbine without causing damage to the unit
- E. Shutting off pump(s) supplying oil to the control-oil system if mineral oil is used
- F. Information on when to shut off AC and DC lube-oil pumps without significant damage to the shaft, as well as guidelines and timing for shutting off AC and DC lube-oil pumps as a last resort in fire situations
- G. A procedure for switching from AC lube-oil pumps to the DC lube-oil pump if this will result in a reduction in pressure and flow rate from a leak while also supplying an adequate amount of oil to bearings to prevent damage
- H. Emergency procedures for driven generators or compressors
- I. A means of venting hydrogen from and purging the generator
- J. Steps needed to isolate electrical equipment in the fire area

2.7.4.2 Provide a method of communication (e.g., mobile phones or radios) for control room operators in the event normal communication methods are interrupted during a fire. Ensure emergency calls will go to the public fire service nearest the facility.

2.7.4.3 Prepare schematics to guide responders and indicate the location, contents, emergency access route, and emergency remote controls for shutting down equipment.

2.7.4.4 Train and authorize designated personnel to be liaisons with the public fire service.

2.7.4.5 Provide the local fire service with sufficient knowledge of turbine fire hazards and response procedures to aid them in conducting firefighting operations. Document this information in the pre-incident plan with the local fire service.

2.7.4.6 Where applicable, account for earthquake perils in the emergency response plan in accordance with Data Sheet 10-1, *Pre-Incident Planning*.

2.7.5 Audits and Management of Change

2.7.5.1 Conduct periodic self-audits of the loss prevention and property conservation programs related to turbine fires.

2.7.5.2 Establish documented procedures to manage the hazards of changes relating to turbine fire hazards, such as modifications to existing processes, installation of new equipment and processes, and changes in personnel.

2.8 Ignition Source Control

2.8.1 Hot Work

2.8.1.1 Establish a hot work permit and supervision program in accordance with Data Sheet 10-3, *Hot Work Management*.

2.8.1.2 Require contractors to adhere to the rules of the facility's hot work permit and supervision policy.

2.8.2 Other Ignition Sources

2.8.2.1 Insulate and shield hot surfaces above the autoignition temperature of mineral oil to prevent deposits or sprays from igniting.

2.8.2.2 Where hot surfaces must be kept uninsulated, remove any combustible accumulations on a daily to weekly frequency, depending upon the rate of accumulation.

3.0 SUPPORT FOR RECOMMENDATIONS

3.1 General

Despite a relatively high flash point, mineral oil used in turbine lubrication and control systems presents a severe hazard due to the potential for a large quantity of oil to escape and ignite an uncontrolled, high-heat-release fire. A mineral oil release and fire in a turbine building can create a significant exposure to critical equipment, production, and the building itself. Fire scenarios include a spray fire, a three-dimensional spill fire, a pool fire, or a combination of these events. The most effective means of limiting damage from oil fires is to quickly shut down the affected oil system. Control-oil systems can usually be shut down quickly. Steam-stop, reheat, and intercept valves are designed to remain open on control-oil pressure. They return to a safe condition when depressurized. Lubricating oil cannot be shut down until the turbine has reached a point where significant additional equipment damage will not occur. Fire protection efforts must include the following:

- A. A comprehensive program to prevent accidental oil releases
- B. An effective emergency shutdown procedure
- C. A combination of active and passive protection features that include construction, curbing, emergency drainage, automatic fire protection, structural steel protection, spray hoods, barriers, and spray fire shields

The key goals of any fire protection scheme are to shut down the fuel supply as quickly as possible, control where the released oil flows, and use automatic sprinkler protection to provide cooling and possible extinguishment of burning pools of oil. This combination of protection elements is used to limit the extent of damage. Turbine buildings contain high values per unit of floor area. Loss of generating capability can result in substantial loss of income.

3.1.1 Release Sources

Oil could be released at flanges, filters, gauges, threaded joints and fittings, sight glasses, oil coolers, bearings, rubber expansion joints (bellows), and hoses, typically due to equipment failure or operator error. The initiating event may be, for example, a mechanical breakdown that severs a lube-oil supply or return line at the bearing connection, releasing a large quantity of oil, which subsequently ignites due to contact with a hot surface. This type of extreme incident is generally assumed to be of relatively low likelihood, but nonetheless is credible and foreseeable based on actual loss history. Oil leakage rates have ranged from 6.5 to 125 gpm (24.6 to 474 L/min). The safeguards recommended in this data sheet are intended to protect against fire exposures created by the escaping burning oil in this type of release and fire scenario.

Failure of welded pipe is not considered a likely release source.

3.1.2 Ignition Sources

Following the release of oil, several ignition sources exist that could cause a significant fire within the turbine area or in auxiliary compartments. The following are some common potential ignition sources:

- A. Electrical equipment

B. Static charge. This is of particular concern in the event of a release of hydrogen.

C. Hot surfaces associated with the equipment (e.g., steam lines and drains). The autoignition temperature of mineral oils used is typically 500°F to 700°F (260°C to 370°C). Temperatures of steam piping around the high-pressure end may be in excess of 1000°F (538°C). Connections to steam piping, such as drain piping or pipe support steel, may not be insulated.

D. Spontaneous ignition. Oil may penetrate insulation and come in contact with a hot surface. The surface temperature, while below the autoignition temperature, may cause spontaneous heating. The heat contained by the insulation results in a rapid increase in the temperature of oil above its autoignition temperature.

E. Smoking

F. Maintenance operations

G. A hydrogen fire. A hydrogen leak that has been ignited may serve to ignite released oil.

The majority of ignition sources are associated with the turbine, due to the presence of high-speed, rotating equipment. However, both ignitable liquid and ignition sources are present in other areas as well. Additionally, the liquids may be pumped at high pressures and flow rates, resulting in the potential for the release of an atomized spray (see Section 3.1.3). A spray of finely atomized droplets may impact the ignition of an ignitable liquid in comparison to a pool or spill. Therefore, while it is important to consider equipment surface temperatures relative to the autoignition temperature of an ignitable liquid, the other ignition sources listed above should not be disregarded.

Where important equipment is exposed by an ignitable liquid (such as lube oil) and a potential ignition source, it is critical to provide fire protection as recommended in this data sheet. Without this protection, even a small fire could lead to significant equipment damage and business interruption.

3.1.3 Oil Fire Hazards

When mineral oil is released under pressure, the resulting atomized spray or mist of oil droplets can extend up to 40 ft (12 m) from the break. The oil spray can be ignited readily by exhaust ducts and steam pipes, electric heaters, open flames, welding arcs, or other hot objects. The resulting fire is torch-like with a very high rate of heat release (Figure 11).

Automatic sprinkler discharge may help limit damage to the building structure and prevent involvement of other combustibles, but the spray fire will not be extinguished and may open an excessive number of sprinklers unless the oil discharge is cut off promptly.

By fitting FM Approved spray fire shields over oil piping flanges, the spray fire hazard at the flange can be reduced to a localized spill and pool fire that can be controlled by local automatic sprinkler protection, curbing, and emergency drainage for the area of the release. FM Approved spray fire shields are subjected to a 45-minute hydrocarbon fire, during which they have demonstrated the ability to maintain their structural integrity and limit the release of oil to within a 5 ft (1.5 m) radius from the centerline of the shield.

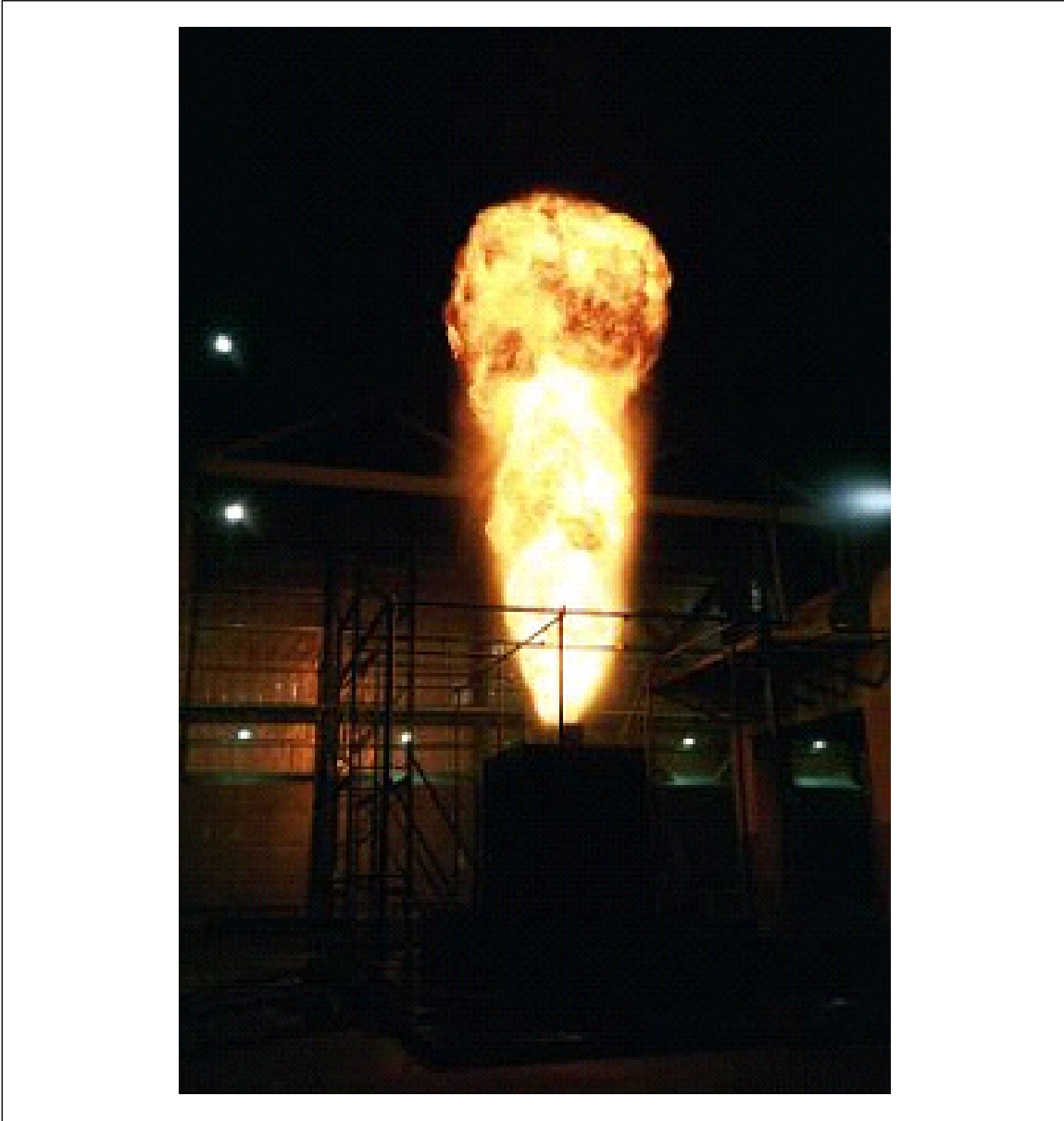

Fig. 11. Mineral oil spray fire (90 psig [6 barg]) demonstration test

3.1.4 FM Approved Industrial Fluids

Electro-hydraulic control (EHC) systems operate at very high pressures (thousands of psi, hundreds of bar) and therefore present potential severe spray fire hazards when the control system is pressurized by mineral oil or other hydrocarbon-based fluid. Some turbine manufacturers use mineral oil from the main lubrication-oil reservoir as the EHC fluid, while others use a separate, smaller reservoir containing EHC fluid that may be hydrocarbon-based.

Mineral oil and other hydrocarbon-based lubricating and hydraulic fluids have relatively high flash points but can be readily ignited by strong ignition sources, such as hot steam piping. Once released and ignited, these fluids will burn with a very high heat release that is typical of all hydrocarbons, regardless of flash point.

Some so-called “fire-resistant fluids” will burn very intensely when released and ignited as a spray or aerosol. FM Approved industrial fluids, which are listed in the *Approval Guide*, are tested to demonstrate a limited heat release rate and inability to stabilize a spray flame, and therefore do not in and of themselves require fire protection.

3.1.5 Oil Fire Hazards Assessment (OFHA)

Loss experience shows that fires resulting in significant property damage and lost generating capacity have resulted from release and ignition of mineral oil in situations where fire protection was not adequate. Where fire protection was not adequate, emergency shutdown and effective fire response were major factors in limiting damage and downtime.

Effective design for fire prevention and damage mitigation requires a thorough understanding the specific fire hazards created by the use of mineral oil in the lubricating, seal, and control-oil systems of turbines and generators. An OFHA is a site-specific, fire-focused engineering analysis of these oil systems, their hazards, and the provided safeguards. An OFHA can be used during the initial design of new facilities as well as for the evaluation of existing fire protection. The OFHA also can play an important role in enhancing fire protection over the life of the facility through the implementation of human element programs, especially through oil fire awareness training using the fire scenarios and drawings that are prepared as part of the assessment.

Involving facility personnel in a team-based approach to the OFHA will help to further their understanding of the hazards and their critical role in oil fire protection. Equally important, these personnel can provide detailed knowledge of oil systems, main equipment layouts, and building features that will help develop realistic fire scenarios.

There is no single prescribed format or method for conducting a hazards assessment. The following is an outline of one possible approach to an OFHA, where the end-product of the assessment is a document that includes a narrative describing the oil system; schematics, drawings, and pictures describing the oil system; design-basis fire scenarios; and safeguards that are or will be in effect.

Consider two scenarios for each mineral oil system: one scenario where release is on a higher level, such as the operating floor, and another where the release is on the ground floor.

A. Basic Design Documentation

1. Compile a description of each mineral oil system, including (a) oil quantity or reservoir capacity, (b) pump flow and pressure, (c) piping diagrams, and (d) piping schematics and drawings.
2. Describe the design details of existing or proposed emergency drainage and containment features for controlling oil releases. Supplement this description with architectural, civil, structural, and equipment arrangement drawings of the facility as needed to support the development of spill scenarios that include the likely flow path(s) of the released oil.
3. Extract design information from these drawings and prepare working schematics to facilitate the analysis and discussion of the fire hazards associated with the oil systems.
4. For existing installations, prepare a set of current photographs of the equipment and oil piping in a "walk-down" format. For both proposed and existing installations, computer-generated isometric views of the power plant in relation to the oil systems also can be prepared to facilitate visualization of the scenarios. The existing design drawings may provide this information.
5. Describe the normal and emergency shutdown procedure for each oil system in a narrative format, including the timing and sequencing of the shutdown. List the designated personnel who can authorize and execute the shutdown. Include a description of the design measures that would allow the operators to remain in the control room to respond during fire emergencies (separate building, room under positive pressure, etc.).
6. Describe the design details for fixed fire protection systems such as automatic sprinklers, foam, and any installed special protection systems.
7. Describe fire protection for high-value, critical equipment and areas (e.g., control rooms, cable spreading and instrumentation rooms, cable trays, switchgear) that may be directly impacted by an oil fire or exposed to nonthermal damage.

B. Determine Oil Release Scenarios

1. Using the compiled information and the prepared schematics, conduct a table-top review of each oil system, identifying the potential oil release sources. Mechanical breakdown and on-line maintenance of oil systems may lead to the release of oil.

2. Consider alternative release points for each mineral oil system. For example, one release may be on an upper level, such as an equipment pedestal, while another release may occur on the ground floor.
3. For each release source, obtain the pressure and flow rate and determine the type of fire: pool spill on a solid floor, three dimensional spill, or oil spray.
4. Loss experience indicates the size of the release is difficult to predict. Estimate the potential release size and resulting fire duration based on the reservoir capacity and inherent limits on oil release (approximately 2/3 to 3/4 of tank capacity).
5. Determine the likely flow path(s) starting from the source and ending at the drains, curbed area, or other low points.
6. Conduct a physical walk-down and revise the release scenario if needed.
7. Document the release scenarios and identify the credible worst cases in terms of size, flow rate, and flow path taken by the released oil.
8. Estimate the release duration based on the emergency shutdown plan and in the event emergency shutdown procedures are not followed (due to unforeseen difficulties that may occur in any fire situation).

C. Determine Oil Fire Scenarios

1. Assuming ignition will occur, assess the potential fire damage to critical equipment and the building based on the release mode, duration, quantity, and flow path of the oil. Take into account the mitigating effects of fixed fire protection systems, drainage, and containment.
2. Conduct a walk-down of the fire area and revise the fire scenario as needed (see Figure 12).
3. Document the fire scenarios and identify worst case scenarios (see Figure 13 for suggested method).

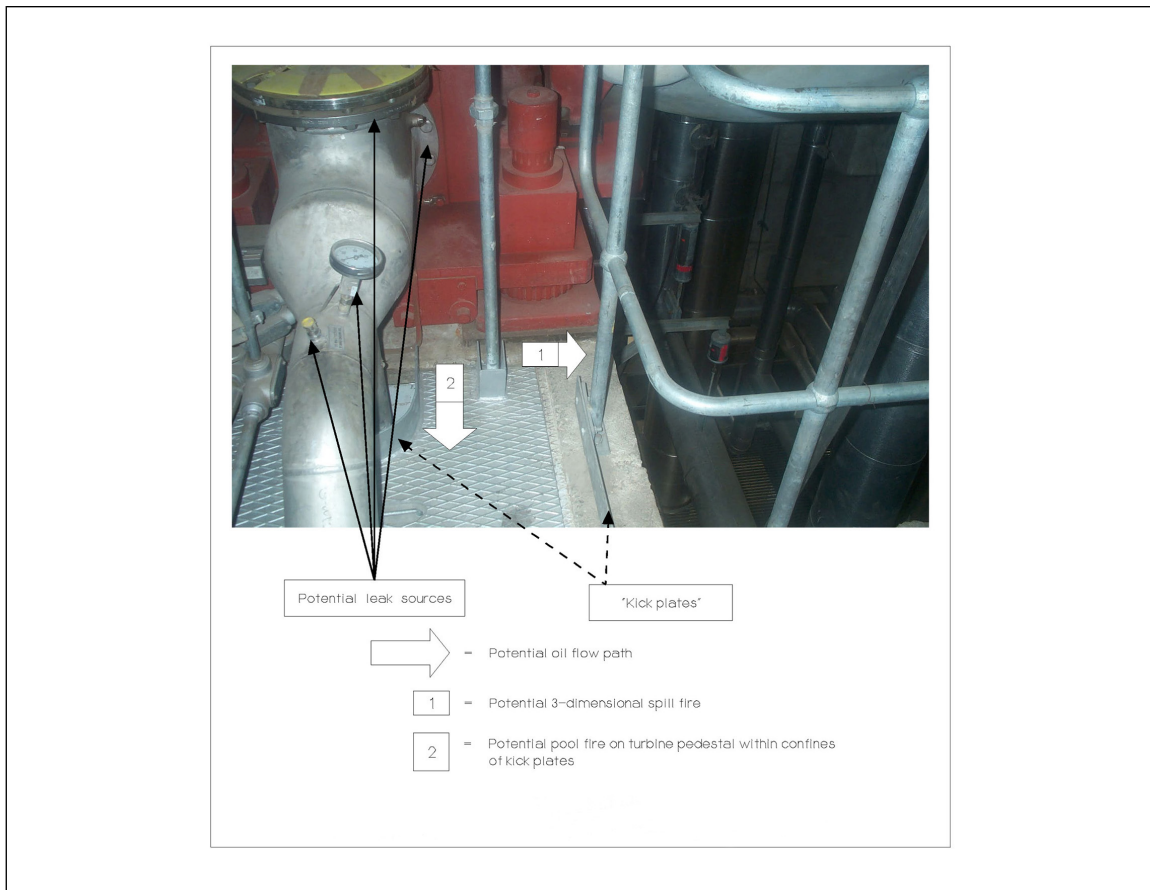

Fig. 12. Walk-down of oil system showing release and flow path

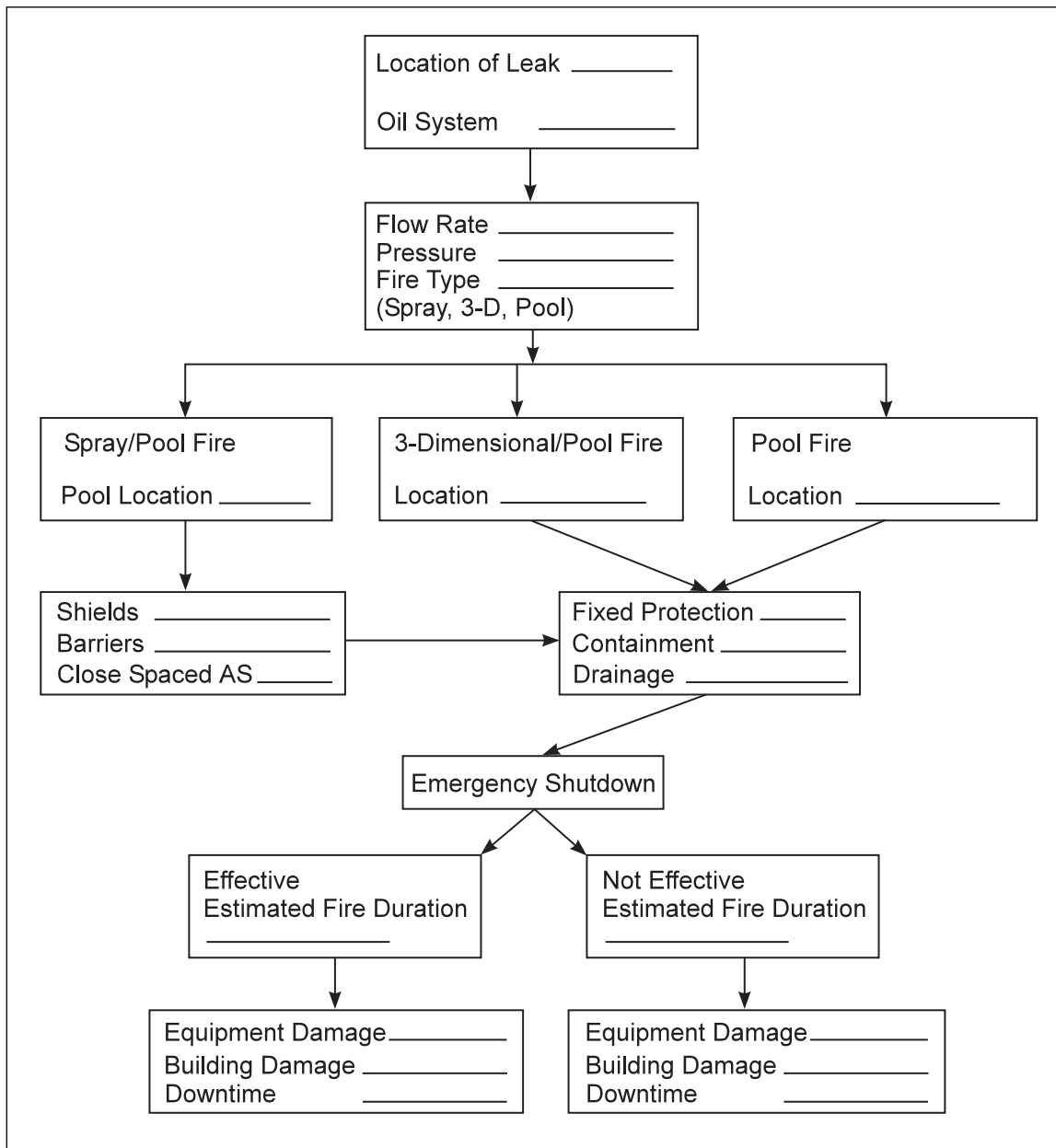

Fig. 13. Suggested outline for development of oil release and fire scenarios

D. Evaluate Adequacy of Fire Protection, including Prevention

1. Assess the impact of the fire scenarios in terms of potential property damage and business interruption for the worst-case scenarios.
2. Determine where it is feasible to prevent or reduce fire damage and downtime through physical protection, such as drainage, containment, and automatic sprinkler protection.
3. Determine if improvements are needed in emergency shutdown plans and fire awareness/ prevention training programs. Ensure the emergency response plan incorporates appropriate measures to limit the size and duration of an oil fire.

E. Implement Action Items

Assign follow-up responsibility for improvements in prevention and mitigation of oil fires.

F. Training and Loss Prevention Programs

1. Use the images, schematics, and findings of the OFHA to train operators and maintenance personnel in the hazards of oil fires.
2. Ensure oil fire awareness training is conducted on an ongoing basis for all employees and reflects the hazard as determined by the OFHA.
3. Incorporate findings into operating and maintenance procedures where appropriate to reduce errors that could result in oil release.

G. Audits and Management of Change

Implement a management of change process for oil systems and safeguards to be certain that no changes occur that could increase the severity or consequence of an oil fire.

3.2 Location and Construction Safeguards

Location and construction safeguards are key to limiting the extent of damage in the event of a turbine fire. These measures provide a passive layer of protection that must typically be planned in the early design phase of a new installation.

3.2.1 Site Layout and Equipment Arrangements

Site layout and equipment arrangements can protect against oil-fire exposures by virtue of hazard isolation features such as separation distance between adjacent units, and between the turbines and their lubrication-oil equipment. For new, large facilities, isolation of the lubrication-oil storage, pumping, and conditioning equipment in a separate fire area from the turbine is a key design goal that can significantly reduce overall fire risk.

3.2.2 Structural Steel Protection

Steel columns supporting critical equipment such as the turbine, generator, and lube-oil equipment can be protected by:

- A. FM Approved fire-rated cementitious (spray-on or trowel-applied) coatings rated for hydrocarbon fires, or
- B. Directional water spray.

Fire-resistant coatings can be applied by spray gun by a contractor licensed by the coating manufacturer. There are normally two coatings applied: a prime coat and an ablative intumescent coating.

When water spray protection is used for protection of steel columns, it is important to have a continuous film of water over the protected area. Fusible link-actuated sprinklers may be used if equipped with shields to prevent cold soldering.

3.2.3 Spill Containment and Emergency Drainage

The key objectives of spill containment and emergency drainage are to:

- A. limit oil pool size.
- B. shorten the path and time for oil to flow to the drains.
- C. confine oil and drain it to areas protected by water spray or sprinklers.
- D. effectively direct the combined oil and fire water discharge from the turbine building to an acceptable location.

Properly engineered containment and emergency drainage is vital to limit the extent of damage that could result from oil fires inside turbine buildings.

3.3 Automatic Fire Protection

3.3.1 Special Extinguishing Systems

Typically, the hazards associated with steam turbines are sufficiently protected by automatic sprinkler or foam-water sprinkler systems. Instances may exist, however, where other types of special extinguishing systems such as carbon dioxide, inert gas, water mist, or hybrid (water mist and inert gas) systems are appropriate. An example is an enclosed space containing oil pumps or conditioning equipment. This data sheet does not focus on special protection systems. Refer to Data Sheet 7-79, *Fire Protection for Gas Turbines and Electric Generators*, for information on the design, installation, testing, and maintenance of these systems.

3.3.2 Automatic Sprinkler Systems

3.3.2.1 Large-scale testing of oil fires indicates increasing density is needed to achieve control of pool fires as the clearance of the sprinklers above the pool increases.

3.3.2.2 Testing also shows that oil-spray and three-dimensional spill fires cannot be extinguished by sprinkler discharge. For these fires, an emergency shutdown plan and proper construction features are key to limiting the extent of damage.

3.3.3 Emergency Shutdown Procedure

The objective of the emergency shutdown procedure is to safely shut down the turbine generator, secure oil pumps, and vent hydrogen from and purge the generator as rapidly as possible. The length of time lube-oil pumps operate is a major factor in damage to the turbine generator and how long a unit is out of service.

The importance of effective operator action was illustrated during a fire when an operator was able to rapidly shut the machine down and turn off lubricating oil. An oil spray fire at the lube-oil reservoir damaged control cable to the turbine, automatically starting the shutdown sequence. The operator broke vacuum. When the shaft stopped rotating, he took the unit off turning gear and shut off oil pumps. The fire was an oil spray fire of approximately 20 gpm (76 L/min) in an unprotected area. The operator's action reduced the rundown time of the turbine from 45-60 minutes to 30 minutes, allowing the public fire service to rapidly control the fire. This reduced the downtime by limiting damage to the operating floor.

When the shaft stops rotating (e.g., liberation of a blade in the low-pressure section), continued oil flow is not expected to reduce internal equipment damage. Where a mechanical event has stopped turbine rotation, shutdown of lube-oil pumps may be the best answer. A fire chief may order lube-oil pumps shut off to prevent severe structural damage or because of life safety concerns.

Operators need emergency procedures that will allow proper action in the event a rapid shutdown is necessary. Consult the turbine manufacturer to determine the speed below which vacuum can be broken, and the speed below which oil pumps can be shut off without causing significant damage to the equipment. Speed must be sufficiently low so there is minimal metal-to-metal contact. In the interim, the heat release rate may be reduced by switching from AC lube-oil pumps to the lower pressure and flow of the DC lube-oil pump.

Providing operators with an emergency shutdown procedure and training them in its implementation is essential. The action an operator takes in the early stages of a fire is critical. Operators also need a safe area in which to perform their necessary actions. In many fires, operators have been forced out of the control room by smoke and heat within minutes after the start of the fire. A room outside the turbine building is best. If the control room is in the turbine building it should be of fire-resistant construction, with penetrations sealed and an independent air supply available to pressurize the room and prevent smoke entry.

Finally, consider the difficulty in tracking the progress of the fire due to smoke limiting visibility. Operators may not know if the fire is controlled. Consider the use of thermal imaging cameras.

3.4 Loss History

Fires occur from accidental release and ignition of oil from turbine lubrication and hydrogen seal-oil systems, control-oil systems if mineral oil is used, and hydrogen from the generator cooling system.

4.0 REFERENCES

4.1 FM

Data Sheet 1-11, *Fire Following Earthquake*
Data Sheet 1-21, *Fire Resistance of Building Assemblies*
Data Sheet 1-29, *Roof Securement and Above Deck Roof Components*
Data Sheet 2-0, *Installation Guidelines for Automatic Sprinklers*
Data Sheet 2-81, *Fire Protection System Inspection, Testing, and Maintenance*
Data Sheet 3-7, *Fire Protection Pumps*
Data Sheet 4-1, *Fixed Water Spray Systems for Fire Protection*
Data Sheet 4-2, *Water Mist Systems*
Data Sheet 4-12, *Foam-Water Sprinkler Systems*
Data Sheet 5-31, *Cables and Bus Bars*
Data Sheet 5-32, *Data Centers and Related Facilities*
Data Sheet 7-29, *Ignitable Liquid Storage in Portable Containers*
Data Sheet 7-32, *Ignitable Liquid Operations*
Data Sheet 7-50, *Compressed Gases in Portable Cylinders and Bulk Storage*
Data Sheet 7-79, *Fire Protection for Gas Turbines and Electric Generators*
Data Sheet 7-83, *Drainage and Containment Systems for Ignitable Liquids*
Data Sheet 7-91, *Hydrogen*
Data Sheet 7-98, *Hydraulic Fluids*
Data Sheet 9-0, *Maintenance and Inspection*
Data Sheet 10-0, *The Human Factor of Property Conservation*
Data Sheet 10-1, *Pre-incident Planning*
Data Sheet 10-3, *Hot Work Management*
Data Sheet 10-4, *Contractor Management*
Data Sheet 13-3, *Steam Turbines*

4.2 Others

National Fire Protection Association (NFPA). *Recommended Practice for Fire Protection for Electric Generating Plants and High Voltage Direct Current Converter Stations*. NFPA 850, 2010 Edition.

APPENDIX A GLOSSARY OF TERMS

Compressed Air Foam (CAF) System: A CAF system consists of a piping system separate from the sprinkler system, an air supply, a foam concentrate supply, a water supply, a mixing system, a detection system and a control panel. When installed for ignitable liquid fire protection, they use the same concentrate as a foam-water sprinkler system. A major advantage to this type of system is that it uses significantly less foam concentrate to produce very high-quality foam. Testing has shown that the delivered foam is very resistant to sprinkler discharge breaking up the blanket. These systems are a supplement to an automatic sprinkler system.

FM Approved: References to "FM Approved" in this data sheet mean a product or service has satisfied the criteria for FM Approval. Refer to the *Approval Guide*, an online resource of FM Approvals, for a complete listing of products and services that are FM Approved.

FM Approved Industrial Fluid: A lubricant or hydraulic fluid that has demonstrated a limited heat release rate and an inability to stabilize a spray flame when tested in accordance with FM Approvals Standard 6930, Approval Standard for Flammability Classification of Industrial Fluids. FM Approved industrial fluids do not in and of themselves require fire protection measures.

Foam-Water Sprinkler System: A foam-water sprinkler system consists of a closed or open head sprinkler system that is connected to a low-expansion foam concentrate proportioning system designed to deliver a fixed foam concentration. The major advantage to installing a foam system is that it can be added to an existing sprinkler system. Closed and open head foam-water sprinkler systems are described in Data Sheet 4-12, *Foam-Water Sprinkler Systems*.

Hybrid (Water and Inert Gas) System: A special protection system that delivers a combination of water and an inert gas (consisting of one or more of the gases helium, neon, argon, nitrogen, and carbon dioxide) through a distribution system. Both the water and the inert gas are critical factors in fire extinguishment, for the purposes of cooling and inerting.

Ignitable Liquid: Any liquid or liquid mixture that is capable of fueling a fire, including flammable liquids, combustible liquids, inflammable liquids, or any other reference to a liquid that will burn. An ignitable liquid must have a fire point.

Inert Gas: An extinguishing agent constituted of the inert gases argon, nitrogen, helium or neon. A blended agent may also include carbon dioxide.

Operating Floor: A floor at the turbine elevation. The floor may extend the length and width of the building (full area operating floor) or it may only be wide enough to allow operator access to the turbine and generator (island design).

Rundown Time: Following a trip of the turbine, the period during which the unit is coasting down from its operating speed to a shutdown condition (typically, once the equipment has been placed on turning gear). Lubrication oil may continue to be supplied to the equipment during this period.

Safe Shutdown: Following the emergency response team's assessment of the fire event, a decision to initiate a prompt, yet controlled shutdown of the equipment. Rotating equipment is considered "shut down" when it has reached a speed where the lubrication-oil system can be turned off without damaging the equipment. Typically, this is achieved once the equipment has been placed on turning gear. Safe shutdown must be accomplished based on an evaluation of the site-specific oil system design, the turbine manufacturer's emergency shutdown system, and emergency response procedures.

Spray barrier: A metal barrier located between a spray source and critical equipment serving to deflect a horizontal spray.

Spray Fire Shield: A device placed around the flanges of pressurized piping systems, used to prevent highly pressurized jets of fluid. The shield is designed to prevent a spray fire from developing by converting a highly pressured spray into a low pressure, low momentum flow of liquid which can be controlled by a properly designed sprinkler system.

Spray Fire Source: Any unguarded flange, fitting, or control device that provides containment for pressurized combustible oil at a high pressure and is connected to a reservoir. Length of the jet flame is determined by pump capacity and assumed pressure and orifice size for the leak.

Spray hood: A horizontally mounted barrier located above a spray source serving to deflect a vertical spray.

Total Flooding System: A fire extinguishing system that relies on filling an enclosure with an extinguishing agent, and maintaining the extinguishing concentration within the enclosure until the fire is extinguished and conditions will not permit reignition. Inert gas and carbon dioxide extinguishing systems are total flooding systems.

Turbine pedestal: The structure the turbine and generator are mounted on. Typically, for larger units, pedestals are of reinforced concrete. Structural steel pedestals are used at some facilities.

Water Mist: A special protection system in which a distribution system is connected to a water supply that is capable of delivering atomized water spray with droplets that are less than 1,000 microns in size. The smaller droplets vaporize and extract heat more rapidly from flames, and are able to extinguish spray fires.

APPENDIX B DOCUMENT REVISION HISTORY

The purpose of this appendix is to capture the changes that were made to this document each time it was published. Please note that section numbers refer specifically to those in the version published on the date shown (i.e., the section numbers are not always the same from version to version).

April 2026. Interim revision. Minor editorial changes were made.

July 2022. Interim revision. Clarifications were made to Section 2.2, Construction and Location, for consistency with Data Sheet 7-79, *Fire Protection for Gas Turbines and Electric Generators*.

October 2021. Interim revision. The following significant changes were made:

- A. Updated cable fire protection to associate fire protection rating with safe shutdown time.

B. Added recommendations for oil-conditioning skids.

October 2020. Interim revision. Added recommendations for providing water mist systems that have been FM Approved for local application over oil pool and 2D spray fire areas.

January 2020. Interim revision. Minor editorial changes were made.

January 2018. Interim revision. Minor editorial changes were made.

July 2013. This document was completely revised. The following major changes have been made:

- A. Replaced references to “flammable” and “combustible” liquids with “ignitable” liquids throughout the document.
- B. Reorganized the document where necessary to provide a format that is consistent with other data sheets.
- C. Clarified recommendations for structural steel protection, including where protection is necessary.
- D. Clarified recommendations for containment and emergency drainage.
- E. Added an option to provide containment of mineral oil without the need for emergency drainage. This option is contingent on several other factors, such as the design of the containment and automatic fire protection features.
- F. Clarified the intent of cable protection. Removed the option to use FM Approved cable coatings as a protection method.
- G. Removed some of the information regarding the protection of compartments using special extinguishing systems. The user is now referred to Data Sheet 7-79, *Fire Protection for Gas Turbines and Electric Generators*, for detailed information on protecting compartments using special protection systems.
- H. Added more general information on the design of sprinkler systems, including guidance on spacing and sprinkler system types.
- I. Reorganized the fire protection recommendations for pool and three-dimensional spill fires for consistency with other data sheets.
- J. Added fire protection recommendations for solid pedestal designs.
- K. Added compressed air foam (CAF) systems as an alternative to emergency drainage, and for supplemental protection of the turbine building.
- L. Clarified the intent of an Oil Fire Hazards Assessment (OFHA).
- M. Added a discussion of ignition sources to Section 3.0, *Support for Recommendations*.
- N. Added recommendations on how to address hydrogen, ignitable liquid, and sprinkler piping systems in areas exposed to earthquakes.
- O. Removed recommendations for hose streams to be included in the capacity of drains and containment.

January 2012. Terminology related to ignitable liquids has been revised to provide increased clarity and consistency with regard to FM Global’s loss prevention recommendations for ignitable liquid hazards.

September 2010. Minor editorial changes were made for this revision.

May 2010. Replaced all references to Data Sheet 2-8N, *Installation of Sprinkler Systems (NFPA)*, with references to Data Sheet 2-0, *Installation Guidelines for Automatic Sprinklers*.

January 2010. Minor editorial changes were made for this revision. Added references to a new Data Sheet 4-12, *Foam-Water Sprinkler Systems*

September 2009. Sprinkler system design criteria for the protection of pool and three-dimensional spill fires has been revised to remain consistent with Data Sheet 7-79, *Fire Protection for Gas Turbines*.

January 2008. Clarification was made to the recommendation 2.4.2.1(d).

May 2007. Minor editorial changes were done for this revision.

January 2007. Clarification was made to the recommendation 2.4.1.5.

September 2006. The following changes were made:

1. Recommendations for open floor turbine facilities were provided.
2. Revised under-floor sprinkler density recommendations.
3. Deleted recommendation 2.2.1.4 for protection of Class 1 steel deck roofs with exposed steel construction for new installations unless roof heights are low enough to expect a pool oil fire to be controlled.
4. Revised recommendation for water supply durations.
5. Revised recommendation for protection of exposed steel building columns and crane rails to apply if automatic sprinkler protection and drainage is not adequate or if the columns are exposed to a 3-dimensional spill fire.
6. Deleted reference to Halon 1301 for protection of relay and cable spreading rooms.
7. Revised recommendation for boiler feed pump protection to exclude small boiler feed pumps where piping or fitting failure would result in release of 100 gal (0.38 m³) of oil or less unless failure could expose high value or critical equipment. Also revised recommendation to include protection for floor areas below boiler feed pumps.
8. Added protection recommendation for DCS rooms.
9. Added recommendation for automatic CO₂ protection of enclosures of directly connected exciters.
10. Added recommendation for protection of fluid drives and variable speed couplings to be protected in the same manner as boiler feed pumps.

September 2000. This revision of the document has been reorganized to provide a consistent format.

April 1990. The following changes were incorporated in the revision of this data sheet.

1. Added recommendation for automatic heat venting.
2. Added recommendation for location of control room and cable spreading rooms for new installations.
3. Added recommendation to shut down isolated phase bus ventilation systems in event of fire on main transformer.
4. Added recommendation for sealing or protecting openings within 20 ft (6.1 m) horizontally of lube oil tank, filter, purifying and centrifuging equipment.
5. Added recommendation for a remotely operated vacuum break system.
6. Added recommendations for separation of control and instrumentation cable between individual units (Section 2.2.5.5 — new installations) and for critical functions such as lube oil pumps.
7. Added details for recommendation for bearing protection.
8. Added recommendations for protection of boiler feed pumps.
9. Increase in sprinkler density to 0.20 gpm/ft². Also, a change in the area requirements to simplify water demand calculations.
10. The section on emergency plans is intended to reduce shutdown time of the turbine generator in event of fire.

APPENDIX C TURBINE OIL SYSTEMS

C.1 Lube-Oil Systems

Lube-oil systems usually include an oil storage tank, an oil reservoir, pumps, coolers, and piping between the tank and turbine-generator.

C.1.1 Mineral Oil

Mineral oil is used for lubricating and cooling the turbine bearings, generator bearings, and bearings of other rotating machines such as exciter and turbine-driven boiler feed pumps. Bearing oil supply pressures are from 15 to 35 psig (1 to 2.4 bar).

The mineral oils typically used have flashpoints of 390°F to 420°F (200°C to 215°C) and autoignition temperatures of 500°F to 700°F (260°C to 370°C).

The oil reservoir for a 15 MW air-cooled generator can contain about 900 gal (3420 L), a 265 MW hydrogen cooled unit about 6000 gal (22,800 L), a 640 MW unit about 10,000 gal (38,000 L), and a 1300 MW unit about 18,000 gal (68,400 L) of oil.

The main oil pump may be shaft-driven, or AC or DC motor-driven. A shaft-driven pump operates when the turbine is at operating speed, and may generate 300 to 500 psi (20.7 to 34.5 bar) to drive an oil ejector located inside the oil reservoir to pump lower-pressure oil to the bearings. An auxiliary oil pump is used to provide oil to turbine bearings until the turbine is at operating speed. Auxiliary oil pumps may be either motor driven or steam turbine-driven. An emergency oil pump driven by a DC motor is also provided. It is usually of a lower flow and pressure rating than the main pump. Electric pumps normally start automatically on pressure drop and can be operated from the control room. Steam turbine-driven pumps typically require manual operation of a steam control valve.

The oil reservoirs of modern turbine generators are usually located below the operating floor, often near the governor end of the turbine. The reservoir may be on the ground floor. A cutoff room is provided in some installations. Pumps, oil coolers, and most of the associated oil equipment are located at the oil tank. Oil coolers for most modern units are plate-type, floor-mounted units located adjacent to the reservoir.

The main supply and return oil piping is parallel to the shaft, with branch lines to bearing housings on the shaft. Main supply and return piping may be below the operating floor with branch lines extending up through the floor to bearing housings. Where main supply and return piping is above the operating floor, it may be in a trench or tunnel or under turbine skirts.

In order to reduce the oil fire hazard presented by a release of oil, safety oil piping is frequently used. In most designs, the high-pressure oil lines to the bearings are located inside return piping (see Figure 4). In another design, both high-pressure and return piping are enclosed in a guard pipe that drains back to the tank. The advantage of both is containment of oil leakage. These methods reduce frequency of oil release and, if properly sized, can be acceptable without automatic sprinkler protection. Small-diameter, high-pressure lines may not be guarded. Lubricating-oil piping normally passes out of the guard system before entering the bearing housing (see Figure 4), and in many designs the oil lines to the generator end bearings are not guarded.

C.1.2 “Fire-Resistant” Lubricants

Experiments have been carried out in the United States, Europe, and Russia on the use of “fire-resistant” fluids for lubrication-oil systems. Testing in the United States was on a 12.5 MW General Electric turbine in Lynn, Massachusetts in the 1970s. Tests in Europe were reported on a 10 MW unit using a triaryl phosphate as a lubricant. The unit was designed for operation on mineral oil and required several modifications to operate on triaryl phosphate.

Russia conducted over 30,000 hours of successful operation on a 300 MW turbine. The successful completion of this test series resulted in the use of a “fire-resistant” fluid in 800 MW turbines. The use of an FM Approved industrial fluid for control, lubricating, and seal-oil systems would eliminate the need for protection for the oil fire exposure.

C.1.3 Control-Oil Systems

Turbine governing control systems modulate the flow of steam to the turbine to hold the turbine speed constant as the load changes. They also are used to operate steam stop, reheat, and intercept valves. Oil pressures of 1600 to 3000 psig (110 to 210 bar) are used.

Older turbines, or turbine generators less than 45 MW, may have a mechanical hydraulic control-oil system using mineral oil. Mechanical hydraulic oil pressures vary between 250 and 350 psig (17 and 23.8 bar). If mineral oil is used, the supply is from the lube-oil reservoir. Turbine manufacturers may try to ensure safety by using the guard pipe system to contain leaks in supply piping. Before the use of FM Approved fluids, fire frequencies involving control-oil systems were about the same as those involving lubricating oil systems.

When FM Approved fluids have been used, fire frequency involving control-oil system fires has been significantly reduced. Triaryl phosphates are most commonly used in the United States. FM Approved fluids may ignite when in contact with a hot surface, but will be unable to stabilize a spray fire.

C.1.4 Seal-Oil Systems

A seal-oil system prevents escape of hydrogen along the generator shaft in a hydrogen-cooled unit. Seal-oil pressures are 5 to 12 psig (0.3 to 0.8 bar) above the hydrogen pressure in the generator.

The seal-oil system uses mineral oil. While it may have its own reservoir, oil make-up to the reservoir is from the main lube-oil reservoir. Failure of a fitting in the seal-oil system could result in the emptying of the contents of the lube-oil reservoir.

One of the reasons for some of the long-duration fires when the oil release has involved the seal-oil system is believed to be the desire of operators to contain hydrogen within the generator. A recent fire involving a seal-oil system resulted in operators refilling the oil reservoir during the fire. This practice was stopped when firefighters on the scene were not able to control the fire. The fire chief ordered the oil system shut off and firefighters were able to quickly extinguish the fire.

C.2 Generators

Generators up to approximately 300 MW may be air-cooled. Air-cooled generators with asphalt-insulated windings have been provided with carbon dioxide extinguishing system protection. Carbon dioxide can be used on energized equipment without damage to windings. A single supply of extinguishing agent, with automatic directional valves to discharge the gas into the generator, may be used to protect two or more generators, thus distributing the cost of protection over several machines. Fires in open, air-cooled generators are usually controlled with portable extinguishers. Where generators have a Class E or F type insulation, the fire can be expected to self-extinguish when the generator is de-energized.

Hydrogen cooling is often used for larger machines. The windings in a conventional hydrogen-cooled generator are cooled by the gas coming in contact with the outer surface of the insulation on the conductors. The gas may be at a pressure of 75 psig (5.1 bar).

Hydrogen-cooled generators have control equipment to maintain the proper gas pressure and purity in the machine. The use of hydrogen in a generator also calls for oil-pressure gland and labyrinth seals to prevent gas leakage where the shaft extends through the generator housing. Hydrogen seal-oil equipment is provided in order to maintain these oil seals.

A concentration of 95% hydrogen is used. This concentration is monitored and maintained during operation. It may also be maintained for short outages. However, for work on the generator or for extended outages, the generator is purged with carbon dioxide.

An explosion hazard exists in the oil system associated with hydrogen-cooled generators. The hydrogen may leak through the oil seals of the machine and accumulate as an explosive mixture in the oil reservoir. Several explosions with localized damage have occurred in older installations. Most installations now include a hydrogen-detaining system that separates air and hydrogen gas from oil and vents it to the outside.

In large machines, stators and/or rotors are cooled internally. Hydrogen gas may be circulated internally through the stator and/or rotor coils. The gas is at varying pressures up to 75 psig (5 bar) and is in direct contact with the conductors. Another cooling method consists of circulating hydrogen through the rotor coils and liquids internally through the stator conductors. Water is also used for cooling. Older generators sometimes used oil. Hydrogen is maintained inside the generator casings of these liquid-cooled machines. Like the conventional hydrogen-cooled type, the gas-conductor-cooled and the liquid-conductor-cooled generators require no special internal fire protection.

Hydrogen may increase the hazard of a turbine generator incident if released in the event of mechanical failure or severe vibration. Fire is the most common result of hydrogen leakage. Incidents have occurred where escaping hydrogen has mixed with air and exploded.

When oil is used as the stator winding cooling liquid, the liquid cooling system, pumps, and associated piping present a fire hazard external to the generator.

C.3 Isolated Phase Bus

Power is delivered from generator to transformers through three isolated phase buses. Air-cooled ducts are most common, although oil-cooled systems have also been used. Cooling is by air drawn from outside the building through one or two ducts. The air is then cooled by a heat exchanger and returned to outside through the remaining duct(s). A fire involving a transformer outside the turbine building will result in smoke being

drawn into the duct(s) and may result in oil mist or vapor being drawn into the bus ducts up to the generator leads. Oil could in turn be ignited and damage bus ducts, the ventilation system, and the underside of the generator.