

INSTALLATION GUIDELINES FOR AUTOMATIC SPRINKLERS

**Table of Contents**

	Page
<b>1.0 SCOPE</b> .....	7
1.1 Hazards .....	7
1.2 Changes .....	7
1.3 Superseded Information .....	8
<b>2.0 LOSS PREVENTION RECOMMENDATIONS</b> .....	8
2.1 General Recommendations for the Installation of Sprinklers .....	8
2.1.1 How to Use This Data Sheet .....	8
2.1.2 Where Sprinklers Are Needed .....	10
2.1.3 Water Supplies for Sprinkler Systems .....	10
2.1.4 General Recommendations for Sprinkler Systems and their Components .....	11
2.1.5 Other Relevant Data Sheets .....	11
2.2 Sprinkler System Types .....	12
2.2.1 General Recommendations for Sprinkler System Types .....	12
2.2.2 Wet-Pipe Sprinkler Systems .....	20
2.2.3 Dry-Pipe Sprinkler Systems .....	20
2.2.4 Preaction Sprinkler Systems .....	21
2.2.5 Refrigerated-Area Sprinkler Systems .....	22
2.2.6 Vacuum Sprinkler Systems .....	24
2.2.7 Deluge Sprinkler Systems .....	24
2.2.8 Antifreeze Solution Sprinkler Systems .....	25
2.2.9 Exposure-Protection Sprinkler Systems .....	27
2.3 Sprinkler System Components .....	27
2.3.1 Control Valves .....	27
2.3.2 Check Valves .....	28
2.3.3 Waterflow Alarms .....	28
2.3.4 Inspector's and By-Pass Test Connections .....	28
2.3.5 Pressure Gauges .....	30
2.3.6 Fire Service Connections .....	30
2.3.7 Drain Valves .....	32
2.3.8 Pressure Relief Valves .....	32
2.3.9 Pressure Reducing Valves .....	32
2.3.10 Orifice Restriction Plates (i.e., Orifice Plates) .....	32
2.3.11 Automatic Breach Containment Valves .....	32
2.4 Sprinkler System Piping .....	32
2.4.1 Sprinkler System Pipe .....	32
2.4.2 Sprinkler System Pipe Connections and Assemblies .....	35
2.4.3 Sprinkler System Pipe Hanging and Bracing .....	37
2.5 Sprinklers .....	42
2.5.1 General Recommendations for Sprinklers .....	42
2.5.2 Nonstorage Pendent and Upright Sprinklers .....	56
2.5.3 Nonstorage Sidewall Sprinklers .....	94
2.5.4 Storage Sprinklers .....	108
2.5.5 Special Protection Sprinklers .....	151
2.6 Plan Review of Sprinkler Systems .....	151
2.6.1 General Recommendations for Plan Review of Sprinkler Systems .....	151
2.6.2 Working Drawings .....	152



2.6.3 Sprinkler System Hydraulic Analysis .....	152
2.6.4 Specifications .....	153
2.6.5 Required Documentation .....	153
2.6.6 Arranging for FM Field Acceptance .....	154
2.7 Sprinkler System Acceptance Tests .....	154
2.7.1 General Recommendations for Sprinkler System Acceptance Tests .....	154
2.7.2 Recommended Documentation for Sprinkler System Acceptance Tests .....	154
2.7.3 Recommended Testing for a Sprinkler System Acceptance Test .....	154
2.8 Operation and Maintenance .....	157
2.9 Ignition Source Control .....	157
<b>3.0 SUPPORT FOR RECOMMENDATIONS .....</b>	<b>157</b>
3.1 General .....	157
3.2 Loss History .....	158
3.2.1 General .....	158
3.2.2 Loss Examples .....	158
<b>4.0 REFERENCES .....</b>	<b>159</b>
4.1 FM .....	159
4.2 Other .....	159
4.2.1 American Welding Society (AWS) .....	159
4.2.2 American Society for Testing and Materials (ASTM) .....	159
<b>APPENDIX A GLOSSARY OF TERMS .....</b>	<b>160</b>
<b>APPENDIX B DOCUMENT REVISION HISTORY .....</b>	<b>175</b>
<b>APPENDIX C FORMS .....</b>	<b>177</b>

## List of Figures

Fig. 2.1.1. Flowchart for navigating the installation recommendations in this data sheet .....	9
Fig. 2.2.1.7.2. An example of arranging grid-type sprinkler systems for flushing .....	15
Fig. 2.2.5.3.1. Example of a sprinkler riser arrangement for a refrigerated-area sprinkler system .....	22
Fig. 2.2.5.4.3. Piping arrangement when using air as the gaseous medium for a refrigerated-area sprinkler system .....	23
Fig. 2.2.8.4.1. Antifreeze solution sprinkler system piping arrangements connected to a potable water supply .....	26
Fig. 2.3.1.2. Examples of arrangements for main sprinkler system control valves .....	27
Fig. 2.3.4.1.5(a). Example arrangement of an inspector's test connection for a dry sprinkler system design using 2 sprinklers on the most remote branch line .....	29
Fig. 2.3.4.1.5(b). Example arrangement of an inspector's test connection for a dry sprinkler system design using 2 sprinklers on the most remote 2 branch lines (4 sprinklers total) .....	29
Fig. 2.3.6. Examples of fire department connection arrangements .....	31
Fig. 2.4.3.2.3.2. Attachment locations for hangers with C-shaped or Z-shaped purlins .....	39
Fig. 2.4.3.3.1.9. Piping arrangement for maximum horizontal distance of 26 ft (8 m) between pipe hangers .	42
Fig. 2.5.1.4. Installation guidelines for sprinklers under a solid mezzanine] .....	46
Fig. 2.5.1.7.1.1. Protection of small conveyor openings using quick-response automatic sprinklers .....	48
Fig. 2.5.1.7.1.2. Protection of conveyor opening in a wall with flow of material handling through the opening only in one direction .....	49
Fig. 2.5.1.7.1.3. Protection of conveyor opening in a wall with flow of material handling through the opening in both directions .....	50
Fig. 2.5.1.7.1.4. Protection of conveyor opening in a floor/ceiling: vertical opening on left; inclined opening on right .....	51
Fig. 2.5.1.7.6.2. Protection of an escalator with a ceiling over the entrance and exit points of the escalator at each floor level .....	54
Fig. 2.5.1.7.7.1. Recommended void area of combustibles for windows not protected by sprinklers .....	54
Fig. 2.5.1.11.1. Example of a return bend for Nonstorage sprinklers .....	56
Fig. 2.5.2.1. Flowchart for applicable Nonstorage pendent and upright sprinklers .....	57
Fig. 2.5.2.1.3.2(a) Flowchart for potential recommendations when a gravity heat/smoke vent less than or equal to 4 ft <sup>2</sup> (0.4 m <sup>2</sup> ) in size must be installed over a nonstorage-type occupancy ....	59
Fig. 2.5.2.1.3.2(b). Flowchart for potential recommendations when a gravity heat/smoke vent larger than 4 ft <sup>2</sup> (0.4 m <sup>2</sup> ) in size must be installed over a nonstorage-type occupancy .....	60

Fig. 2.5.2.1.3.2(c). Protection of vent openings at ceiling level, such as gravity heat/smoke vents, natural draft exhaust vents or mechanical exhaust vents using a flat, continuous, false ceiling and additional ceiling-level sprinklers .....	61
Fig. 2.5.2.1.3.2(d). Protection of vent openings at ceiling level, such as gravity heat/smoke vents, natural draft exhaust vents or mechanical exhaust vents, located over a nonstorage-type occupancy, using additional quick-response ceiling-level sprinklers .	61
Fig. 2.5.2.1.4. Flowchart for potential recommendations when a natural draft exhaust vent is to be installed over a nonstorage-type occupancy .....	62
Fig. 2.5.2.1.5. Flowchart for potential recommendations when a mechanical exhaust vent is to be installed over a nonstorage-type occupancy. ....	63
Fig. 2.5.2.1.6(a). Acceptable ceiling-level sprinkler arrangement for the protection of a nonstorage-type occupancy in the presence of a ridge vent up to 10 ft (3.0 m) wide, using additional quick-response ceiling-level sprinklers installed within the footprint of the ridge vent .....	64
Fig. 2.5.2.1.6(b). Acceptable ceiling-level sprinkler arrangement for the protection of a nonstorage-type occupancy in the presence of a ridge vent greater than 10 ft (3.0 m) wide using additional quick-response ceiling-level sprinklers installed below the ridge vent .....	65
Fig. 2.5.2.1.6(c). Acceptable ceiling-level sprinkler arrangement for the protection of a nonstorage-type occupancy in the presence of a ridge vent up to 10 ft (3.0 m) wide using additional quick-response ceiling-level sprinklers installed within the ridge vent .....	66
Fig. 2.5.2.1.6(d). Acceptable ceiling-level sprinkler arrangement for the protection of a nonstorage-type occupancy in the presence of a ridge vent greater than 10 ft (3.0 m) wide using additional quick-response ceiling-level sprinklers installed within the ridge vent .....	67
Fig. 2.5.2.1.8. Flowchart to determine if sprinklers are needed within a ceiling pocket of a non-storage area protected by pendent or upright sprinklers .....	69
Fig. 2.5.2.1.9.1(a). Example of airflow velocities created by ceiling-mounted equipment such as HVLS type fans .....	70
Fig. 2.5.2.1.9.1(b). Acceptable arrangement of additional ceiling-level sprinklers in areas where airflow velocities exceed 5 ft/sec (1.5 m/sec) over a nonstorage-type occupancy. ....	71
Fig. 2.5.2.2.1. Flowchart for determining ceiling construction type for Nonstorage pendent and upright sprinklers .....	72
Fig. 2.5.2.3.2. Horizontal distances from walls and wall corners to Nonstorage pendent and upright sprinklers .....	76
Fig. 2.5.2.3.3.1. Measuring vertical distance between a Nonstorage sprinkler's thermal element and the underside of the ceiling .....	77
Fig. 2.5.2.3.3.2. How to measure the vertical distance between the thermal element of Nonstorage pendent and upright sprinklers and the underside of a corrugated ceiling .....	77
Fig. 2.5.2.3.3.3. Vertical distance between ceiling and centerline of sprinkler's thermal element in the presence of mineral wool or glass fiber batt insulation .....	78
Fig. 2.5.2.3.3.4. Vertical location of Nonstorage pendent and upright sprinklers under unobstructed ceiling construction for various ceiling heights .....	79
Fig. 2.5.2.3.4.1(a). Guidelines involving ceiling slope with Nonstorage sprinklers .....	80
Fig. 2.5.2.3.4.1(b). Location of Nonstorage pendent and upright sprinklers near ceiling peak when slope exceeds 1 in 12 (5°) .....	81
Fig. 2.5.2.3.4.1(c). Recommended sprinkler installation per Figure 2.5.2.3.4.1(a) when ceiling slope exceeds 4 in 12 (18.5°) .....	81
Fig. 2.5.2.4.2. Determining the horizontal and vertical location of Nonstorage pendent and upright sprinklers in the presence of obstructed ceiling construction .....	83
Fig. 2.5.2.4.4. Vertical location of Nonstorage pendent and upright sprinklers under obstructed ceiling construction .....	85
Fig. 2.5.2.4.5. Channel-blocking each channel created by obstructed ceiling construction .....	86
Fig. 2.5.2.5.1.1(a). Objects near ceiling level not considered obstructions to standard-coverage Nonstorage pendent and upright sprinklers .....	87
Fig. 2.5.2.5.1.1(b). Objects near ceiling level not considered obstructions to extended-coverage Nonstorage pendent and upright sprinklers .....	87

Fig. 2.5.2.5.2.1(a). Example of ceiling structural members that obstruct sprinkler discharge pattern .....	88
Fig. 2.5.2.5.2.1(b). Positioning ceiling-level sprinklers when ceiling structural members obstruct sprinkler discharge .....	89
Fig. 2.5.2.5.3.1. Example of an “Individual Object” and a “Grouped Object” for analyzing obstructions ...	90
Fig. 2.5.2.5.9. Flowchart to determine if a conveyor is an obstruction to ceiling sprinkler discharge .....	93
Fig. 2.5.3.1.3. Flowchart to determine if sprinklers are needed within a ceiling pocket of a non-storage area protected by sidewall sprinklers .....	95
Fig. 2.5.3.2.2.1(a). Horizontal distances from Nonstorage sidewall sprinklers to walls .....	97
Fig. 2.5.3.2.2.1(b). Horizontal distances from Nonstorage sidewall sprinklers to wall corners .....	98
Fig. 2.5.3.3.1. Vertical location of Nonstorage sidewall sprinklers .....	98
Fig. 2.5.3.3.3. Location of Nonstorage sidewall sprinklers near ceiling peak when slope exceeds 1 in 12 (5°) .....	99
Fig. 2.5.3.4.6. Horizontal distances from Nonstorage K14.0EC (K200EC) horizontal sidewall sprinkler to walls .....	100
Fig. 2.5.3.4.7. Vertical location of Nonstorage K14.0EC (K200EC) horizontal sidewall sprinklers below ceiling .....	101
Fig. 2.5.3.4.8. Vertical location of Nonstorage K14.0EC (K200EC) horizontal sidewall sprinklers at roof peak .....	101
Fig. 2.5.3.5.1.1(a). Objects near ceiling level not considered obstructions to standard-coverage Nonstorage sidewall sprinklers away from the mounting wall .....	102
Fig. 2.5.3.5.1.1(b). Objects near ceiling level not considered obstructions to extended-coverage Nonstorage sidewall sprinklers away from the mounting wall .....	102
Fig. 2.5.3.5.1.2(a). Objects near ceiling level not considered obstructions to standard-coverage Nonstorage sidewall sprinklers along the mounting wall .....	103
Fig. 2.5.3.5.1.2(b). Objects near ceiling level not considered obstructions to extended-coverage Nonstorage sidewall sprinklers along the mounting wall .....	103
Fig. 2.5.3.5.2.1(a). Example of ceiling structural members that obstruct sidewall sprinkler discharge pattern .....	104
Fig. 2.5.3.5.2.1(b). Positioning ceiling-level sprinklers when ceiling structural members obstruct sprinkler discharge .....	105
Fig. 2.5.3.5.2.5. Nonstorage sprinklers under combustible shielded areas more than 8 in. (200 mm) deep .....	106
Fig. 2.5.3.5.3.1. Example of an “Individual Object” and a “Grouped Object” for analyzing obstructions ..	106
Fig. 2.5.4.1. Flowchart for applicable Storage sprinklers .....	109
Fig. 2.5.4.1.3.2(a). Flowchart for potential recommendations when a gravity heat/smoke vent less than or equal to 4 ft <sup>2</sup> (0.4 m <sup>2</sup> ) in size must be installed over a storage occupancy ..	111
Fig. 2.5.4.1.3.2(b). Flowchart for potential recommendations when a gravity heat/smoke vent larger than 4 ft <sup>2</sup> (0.4 m <sup>2</sup> ) in size must be installed over a storage occupancy .....	112
Fig. 2.5.4.1.3.2(c). Protection of vent openings at ceiling level, such as gravity heat/smoke vents, natural draft exhaust vents or mechanical exhaust vents, using a flat, continuous, false ceiling and additional ceiling-level sprinklers .....	113
Fig. 2.5.4.1.3.2(d). Protection of vent openings at ceiling level, such as gravity heat/smoke vents, natural draft exhaust vents or mechanical exhaust vents, located over a storage occupancy by the use of additional quick-response, ceiling-level sprinklers .	113
Fig. 2.5.4.1.3.2(e). Protection of vent openings at ceiling level, such as gravity heat/smoke vents, natural draft exhaust vents or mechanical exhaust vents, located over a storage occupancy by the use of in-rack sprinklers .....	114
Fig. 2.5.4.1.4. Flowchart for potential recommendations when a natural draft exhaust vent is to be installed over a storage occupancy .....	115
Fig. 2.5.4.1.5. Flowchart for potential recommendations when a mechanical exhaust vent is to be installed over a storage occupancy .....	116
Fig. 2.5.4.1.6(a). Acceptable ceiling-level sprinkler arrangement for the protection of a storage occupancy in the presence of a ridge vent up to 10 ft (3.0 m) wide, using additional ceiling-level sprinklers installed within the ridge vent .....	117
Fig. 2.5.4.1.6(b). Acceptable ceiling-level sprinkler arrangement for the protection of a storage occupancy in the presence of a ridge vent over 10 ft (3.0 m) wide, using additional ceiling-level sprinklers installed within the ridge vent .....	118

Fig. 2.5.4.1.6(c). Acceptable ceiling-level sprinkler arrangement for the protection of a storage occupancy in the presence of a ridge vent up to 4 ft (1.2 m) wide, using additional quick-response, ceiling-level sprinklers installed below the ridge vent	119
Fig., 2.5.4.1.6(d). Acceptable ceiling-level sprinkler arrangement for the protection of a storage occupancy in the presence of a ridge vent greater than 4 ft (1.2 m) wide using additional quick-response ceiling-level sprinklers installed below the ridge vent	120
Fig. 2.5.4.1.8. Flowchart to determine if sprinklers are needed within a ceiling pocket of a storage area protected by pendent or upright sprinklers	122
Fig. 2.5.4.1.9.1. Flowchart for acceptable protection options when airflow velocities exceed 5 ft/sec (1.5 m/sec) at or below ceiling-level sprinklers protecting a storage occupancy	123
Fig. 2.5.4.1.9.1(a). Example of airflow velocities created by ceiling-mounted equipment, such as HVLS type fans	124
Fig. 2.5.4.1.9.1(b). Acceptable arrangement of additional ceiling-level sprinklers in areas where airflow velocities exceed 5 ft/sec (1.5 m/sec)	124
Fig. 2.5.4.2.1. Flowchart for determining ceiling construction type for Storage sprinklers	125
Fig. 2.5.4.3.2. Horizontal distances from walls and wall corners to Storage sprinklers	127
Fig. 2.5.4.3.3.1. Measuring vertical distance between Storage sprinkler's thermal element and underside of ceiling	128
Fig. 2.5.4.3.3.2. How to measure the vertical distance between the thermal element of Storage sprinklers and the underside of a corrugated ceiling	128
Fig. 2.5.4.3.3.3. Vertical distance between ceiling and centerline of sprinkler's thermal element in the presence of mineral wool or glass fiber batt insulation	129
Fig. 2.5.4.3.3.4. Vertical location of Storage sprinklers under unobstructed ceiling construction for various ceiling heights	129
Fig. 2.5.4.3.4.1(a). Guidelines involving ceiling slope with Storage sprinklers under unobstructed ceiling construction	130
Fig. 2.5.4.3.4.1(b). Location and arrangement of Storage sprinklers near ceiling peak when slope exceeds (a) 1 in 12 (5°), and (b) 2 in 12 (10°)	131
Fig. 2.5.4.3.4.2. Option 1 per Figure 2.5.4.3.4.1(a) involving the installation of a flat, continuous, false ceiling with additional ceiling sprinklers	131
Fig. 2.5.4.4.2. Determining the horizontal and vertical location of Storage sprinklers in the presence of obstructed ceiling construction	133
Fig. 2.5.4.4.4. Vertical location of Storage sprinklers under obstructed ceiling construction for ceiling slopes of (a) up to 2 in 12 (10°), and (b) up to 4 in 12 (18.5°)	135
Fig. 2.5.4.4.5. Channel-blocking each channel created by obstructed ceiling construction	136
Fig. 2.5.4.5.1.1(a). Objects near ceiling level not considered obstructions to standard-coverage Storage sprinklers	137
Fig. 2.5.4.5.1.1(b). Objects near ceiling level not considered obstructions to extended-coverage Storage sprinklers	137
Fig. 2.5.4.5.2.1(a). Example of ceiling structural members that obstruct sprinkler discharge pattern	138
Fig. 2.5.4.5.2.1(b). Positioning ceiling-level sprinklers when ceiling structural members obstruct sprinkler discharge	139
Fig. 2.5.4.5.3.1. Example of an "Individual Object" and a "Grouped Object" for analyzing obstructions	140
Fig. 2.5.4.5.4.3. Allowable extension of maximum ceiling sprinkler spacing to avoid obstruction to sprinkler discharge	142
Fig. 2.5.4.5.4.4(a). Installing supplemental sprinklers under an obstructing object that is either not flat or is not solid	143
Fig. 2.5.4.5.4.4(b). Installing supplemental sprinklers within a storage rack under an obstructing object up to 2 ft (0.6 m) wide	143
Fig. 2.5.4.5.5.4(a). Supplemental sprinklers installed below non-flat or non-solid obstructions, per Section 2.5.4.5.5	146
Fig. 2.5.4.5.5.4(b). Additional ceiling-level sprinklers installed within a storage rack below an obstructing object less than or equal to 4 ft (1.2 m) wide	147
Fig. 2.5.4.5.9. Flowchart to determine if supplemental Storage sprinklers are needed below conveyors	149
Fig. 2.5.4.6.8. Example of protecting in-rack sprinklers and sprinkler piping in a double-row rack	151
Fig. A-1. Example of a double-tee concrete slab	162

Fig. A-2. Example of a flushing connection with a threaded end cap ..... 166

## List of Tables

Table 2.1.3.5. Flow Required to Produce a Waterflow Velocity of 10 ft/sec (3 m/sec) Through Underground Mains .....	11
Table 2.2.1.3.3. Default Hazen-Williams C-Values for Sprinkler System Hydraulic Calculations .....	13
Table 2.2.8.2.2. Acceptable Non-FM Approved Antifreeze Solutions and the Recommended Concentration Levels for Conditions Outlined in Section 2.2.8.2 .....	25
Table 2.4.1.1.2.1(a). Minimum Wall Thickness for Steel Pipe Installed Over Water-Sensitive Occupancies; Nominal Pipe Sizes Measured in Inches .....	33
Table 2.4.1.1.2.1(b). Minimum Wall Thickness for Steel Pipe Installed Over Water-Sensitive Occupancies; Nominal Pipe Sizes Measured in Millimeters .....	33
Table 2.4.1.1.4.2. Recommended Minimum Wall Thickness of Steel Sprinkler Pipe Where the Minimum Radius Bend is Less Than 12-Pipe Diameters .....	34
Table 2.4.2.2.1(1). Recommended Minimum Steel Pipe Wall Thickness for Threaded, Roll-Grooved, Cut-Grooved, and Welded Sprinkler Piping in Inches .....	36
Table 2.4.2.2.1(2). Recommended Minimum Steel Pipe Wall Thickness for Threaded, Roll-Grooved, Cut-Grooved, and Welded Sprinkler Piping in Millimeters .....	36
Table 2.4.3.1.3. Recommended Minimum Steel Rod Sizes and Thread Engagement Lengths .....	37
Table 2.4.3.3.1.1. Recommended Maximum Horizontal Distance Between Pipe Hangers Supporting Steel Sprinkler Pipe .....	40
Table 2.4.3.1.1(1). Minimum Wall Thickness of Sprinkler Piping for Use with Table 2.4.3.3.1.1 .....	41
Table 2.5.1.1.1. Nominal Temperature Ratings of Sprinklers Based on the Maximum Ambient Temperature at the Sprinkler .....	43
Table 2.5.1.1.2. Minimum Design Pressures for Sprinklers .....	44
Table 2.5.1.1.2. Minimum Design Pressures for Sprinklers (continued) .....	45
Table 2.5.1.7.1.6(a). Recommended Minimum Discharge Density from Spray Nozzles .....	52
Table 2.5.1.7.1.6(b). Recommended Maximum Mounting Distance of Spray Nozzles from Protected Openings With Enclosures .....	52
Table 2.5.2.1.1(a). Nominal K-factor Values of FM Approved Nonstorage Sprinklers .....	56
Table 2.5.2.1.1(b). Recommended Minimum Allowable Nonstorage Pendent and Upright Sprinkler K-factors .....	58
Table 2.5.2.2.1. Determining Ceiling Construction Type When Solid Structural Members Deeper than 4 in. (100 mm) are Present .....	73
Table 2.5.2.3.1.1(a). Spacing of Ceiling-Level Nonstorage Pendent and Upright Sprinklers for Hazard Category No.1 Under Unobstructed Ceiling Construction .....	74
Table 2.5.2.3.1.1(b). Spacing of Ceiling-Level Nonstorage Pendent and Upright Sprinklers for Hazard Category No. 2 Under Unobstructed Ceiling Construction .....	75
Table 2.5.2.3.1.1(c). Spacing of Ceiling-Level Nonstorage Pendent and Upright Sprinklers for Hazard Category No. 3 Under Unobstructed Ceiling Construction .....	75
Table 2.5.2.5.6.2. Spacing Guidelines for Ceiling Sprinklers Located Above the Open-Grid Ceiling in the Presence of an Open-Grid Ceiling. ....	91
Table 2.5.3.2.1.1(a). Spacing of Ceiling-Level Nonstorage Sidewall Sprinklers for Hazard Category No. 1 .	96
Table 2.5.3.2.1.1(b). Spacing of Ceiling-Level Nonstorage Sidewall Sprinklers for Hazard Category No. 2 .	96
Table 2.5.3.4.5. Recommended Spacing of Nonstorage K14.0EC (K200EC) Horizontal Sidewall Sprinklers for Hazard Category Nos. 1, 2, and 3 .....	100
Table 2.5.3.5.6.2. Recommended Spacing Guidelines for Ceiling Sidewall Sprinklers in the Presence of an Open-Grid Ceiling .....	108
Table 2.5.4.1.1. Nominal K-factor Values of FM Approved Storage Sprinklers .....	110
Table 2.5.4.2.1. Determining Ceiling Construction Type When Solid Structural Members Deeper than 4 in. (100 mm) Are Present .....	126
Table 2.5.4.3.1.1. Spacing of Ceiling-Level Storage Sprinklers Under Unobstructed Ceiling Construction .	126
Table 2.5.4.5.4.1. Acceptable Location of Obstructing Objects from Ceiling Sprinklers .....	141

## 1.0 SCOPE

This FM property loss prevention data sheet contains recommendations for the installation of automatic sprinkler systems that consist of automatic sprinklers and their aboveground supporting components.

This data sheet provides guidance on the following:

- Components used as part of a sprinkler system
- Securing and supporting these components
- The response time of sprinklers to a fire
- The distribution of sprinkler discharge to a fire area
- The documentation required for an FM plan review
- The information required for an FM acceptance test

This data sheet does **not** provide guidance on:

- Designs for ceiling or in-rack sprinkler systems (see the relevant occupancy-specific data sheet for design guidelines). This data sheet does, however, provide design information for supplemental sprinklers. In addition, this data sheet provides the minimum recommended design pressures for ceiling and in-rack sprinklers.
- Maintenance required for sprinkler systems (see Data Sheet 2-81, *Fire Safety Inspections and Sprinkler System Maintenance*)
- Underground piping or water supplies for sprinkler systems (see Data Sheet 3-10, *Private Fire Service Mains and Connections*, and other relevant 3-series data sheets)
- Protection of sprinkler system piping from internal corrosion (see Data Sheet 2-1, *Corrosion in Automatic Sprinkler Systems*)
- Designs for the installation of piping in areas designated as 50-year through 500-year earthquake zones as defined in Data Sheet 1-2, *Earthquakes* (see Data Sheet 2-8, *Earthquake Protection for Water-Based Fire Protection Systems*)

## 1.1 Hazards

Refer to the following FM Understanding the Hazard (UTH) brochures for information on hazards related to sprinkler installations:

- Corrosion in Sprinkler Systems (P0109)
- Freeze (P0148)
- Ice Plugs (P0118)
- Ice Plugs in Dry-Pendent Sprinklers in Freezers (P0382)
- Inadequate Ceiling Sprinkler Protection in Storage Facilities (P253)
- Lack of Automatic Sprinklers (P0037)
- Storage Sprinkler Installation Issues (P0477)

## 1.2 Changes

**April 2026.** Interim revision. The following modifications were incorporated into this edition of the data sheet:

A. Section 2.5.1.1.2 on minimum design pressures for sprinklers has been updated based on recent testing. It also now includes the minimum design pressure for all FM Approved sprinklers.

B. Table 2.5.4.5.4.1, which provides guidance on the acceptable location of obstructing objects from nearby ceiling sprinklers, has been revised to better clarify the guidelines provided in the third column of the table.

C. Sections 2.5.4.5.4 and 2.5.4.5.5 have been modified to pull all the guidance from Section 2.5.4.5.5 specific to obstructing objects no wider than 2 ft (0.6 m) and relocate them into Section 2.5.4.5.4.

D. Section 2.4.1.1.5.2 has been updated to indicate that FM Approved stretched-reduced mill manufactured steel pipe can be installed without consideration for the weld line's alignment relative to the floor.

### 1.3 Superseded Information

This data sheet incorporates and supersedes Data Sheet 8-29, *Refrigerated Storage*.

This data sheet incorporates and supersedes the following public engineering bulletins:

- EB 08-05, *Use of Smoke Detection to Activate a Refrigerated Area Sprinkler System*
- EB 02-11, *High-Volume Low-Speed (HVLS) Fan and Sprinkler Performance*

## 2.0 LOSS PREVENTION RECOMMENDATIONS

### 2.1 General Recommendations for the Installation of Sprinklers

#### 2.1.1 How to Use This Data Sheet

As with any data sheet, a complete and comprehensive understanding of the information in this document can only be achieved by a thorough review of its contents. To assist with the proper use of this data sheet, however, a flowchart has been provided (see Figure 2.1.1). Use this flowchart in combination with the text of this data sheet to determine the recommendations for the installation of an automatic sprinkler system.

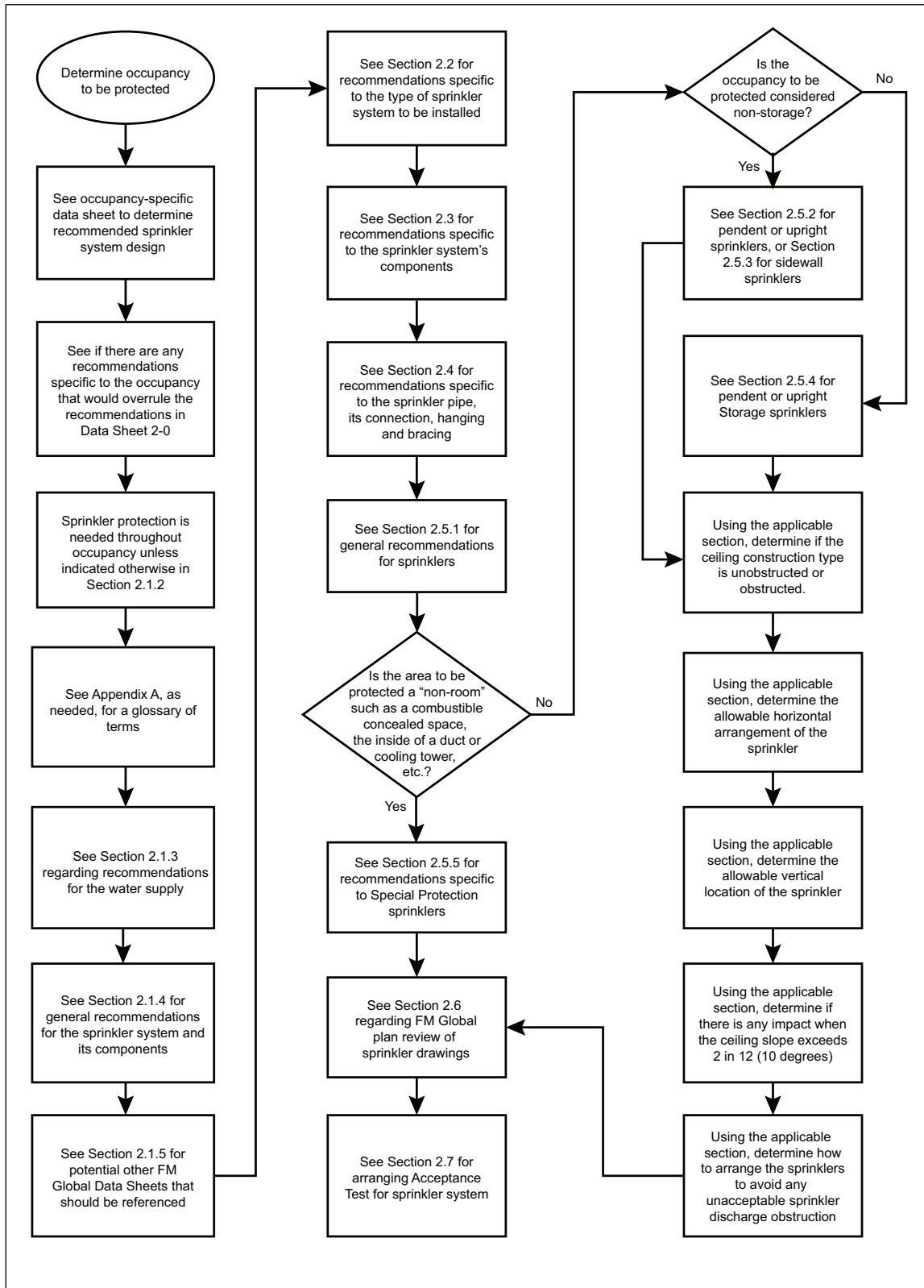

Fig. 2.1.1. Flowchart for navigating the installation recommendations in this data sheet

## 2.1.2 Where Sprinklers Are Needed

2.1.2.1 Install sprinklers throughout all portions of a building in accordance with this data sheet to protect it from fire damage.

2.1.2.2 Sprinkler protection can be omitted from portions of a building in which both the construction and the occupancy of the affected building area are noncombustible.

2.1.2.3 See the relevant occupancy-specific data sheet for design criteria (i.e., sprinkler system design, hose stream allowance, and sprinkler system duration) for the sprinkler system. Determine if there are any specific recommendations in the occupancy-specific data sheet that might supersede the general recommendations given in this data sheet.

2.1.2.4 Fixed special protection extinguishing systems, including oxygen reduction systems, are not an alternative to sprinkler protection unless the relevant occupancy-specific data sheet specifies they are.

## 2.1.3 Water Supplies for Sprinkler Systems

2.1.3.1 Provide each sprinkler system with at least one reliable water supply capable of meeting the total flow and pressure demand (ceiling, in-rack, and hose stream), and duration for the occupancy hazard the sprinkler system is designed to handle. See additional information in Data Sheet 3-29, *Reliability of Fire Protection Water Supplies*.

2.1.3.2 Arrange the piping network for the water supply in accordance with Data Sheet 3-10, *Private Fire Service Mains and Connections*.

2.1.3.3 See other 3-series data sheets for additional information regarding the type of water supply being provided. Applicable data sheets, in addition to Data Sheet 3-29 and Data Sheet 3-10, could include the following:

- Data Sheet 3-1, *Tanks and Reservoirs for Interconnected Fire Service and Public Mains*
- Data Sheet 3-2, *Water Tanks for Fire Protection*
- Data Sheet 3-4, *Embankment-Supported Fabric Tanks*
- Data Sheet 3-6, *Lined Earth Reservoirs for Fire Protection*
- Data Sheet 3-7, *Fire Protection Pumps*

2.1.3.4 The water supply for domestic use can tap off the water supply for a sprinkler system if the feed connection for the domestic supply is upstream of both:

- A. The waterflow alarm on the sprinkler system riser, and
- B. The fire service connection.

2.1.3.5 Prior to making the connection to the sprinkler system, completely flush all underground mains and lead-in connections that feed sprinkler system risers until the water runs clear. Flushing can be accomplished through hydrants at dead ends of the system or through accessible aboveground flushing outlets. If water is supplied from more than one source or from a looped system, close divisional valves as needed to produce a high-velocity flow through each single leg of the underground's network of piping. Acceptable minimum flushing flow rates are as follows:

- A. The hydraulically calculated water demand rate of the system including any hose requirements, or
- B. The flow necessary to provide a velocity of 10 ft per sec (3 m/sec) as indicated in Table 2.1.3.5, or
- C. The maximum flow rate available to the system under fire conditions.

Table 2.1.3.5. Flow Required to Produce a Waterflow Velocity of 10 ft/sec (3 m/sec) Through Underground Mains

Pipe Size, in. (mm)	Flow Rate, gpm	Flow Rate, L/min
4 (100)	390	1475
6 (150)	880	3330
8 (200)	1560	5905
10 (250)	2440	9235
12 (300)	3520	13325

#### 2.1.4 General Recommendations for Sprinkler Systems and their Components

2.1.4.1 Install only new, FM Approved (where available), sprinkler system components.

2.1.4.2 Ensure the application of each component is in accordance with the following:

- A. Its listing in the *Approval Guide*, and
- B. The manufacturer's installation instructions, and
- C. The relevant occupancy-specific data sheet, and
- D. Any specific jurisdictional requirements

2.1.4.3 Ensure the sprinkler system components are compatible with each other as well as the environment in which they will be installed, including the highest expected internal pressure, and the lowest and highest ambient temperatures.

2.1.4.4 Applicable sprinkler system components include, but are not limited to, the following:

- Sprinklers and sprinkler escutcheons
- Sprinkler system valves (alarm check, dry-pipe, deluge, etc.) and their accessories
- Sprinkler system control valves
- Check valves (check, backflow, etc.)
- Waterflow alarms
- Sprinkler system inspector's test connections
- Pressure gauges
- Fire service connections
- Drain valves
- Pressure relief valves
- Pressure reducing valves
- Sprinkler pipe
- Sprinkler pipe connections and pipe assemblies
- Sprinkler pipe hanging and bracing supports

#### 2.1.5 Other Relevant Data Sheets

In addition to the guidelines in this data sheet, see the following data sheets for potential additional guidelines that could affect the installation and design of automatic sprinkler systems:

- Data Sheet 1-20, *Protection Against Exterior Fire Exposure*, for recommendations related to installing exposure sprinklers for the protection of exterior hazards, such as large oil-filled transformers, exterior loading docks, yard storage, etc. that are close to a building that either has or requires sprinkler protection
- Data Sheet 1-57, *Plastics in Construction*, to determine what supplemental protection related to sprinkler protection might be recommended when plastic construction materials are introduced into the area to be protected

- Data Sheet 2-1, *Corrosion in Automatic Sprinkler Systems*, for recommendations on how to prevent internal corrosion in sprinkler system piping when sprinkler system components will be installed in atypical environments, such as corrosive, low-temperature, or high-temperature type of environments
- Data Sheet 2-8, *Earthquake Protection for Water-Based Fire Protection Systems*, for sprinkler systems that will be installed in 50-year through 500-year earthquake zones (as defined by Data Sheet 1-2, *Earthquakes*)
- Data Sheet 2-81, *Fire Safety Inspections and Sprinkler System Maintenance*, regarding the recommendations on how to care for a sprinkler system once it has been installed
- Data Sheet 3-26, *Fire Protection for Nonstorage Occupancies*, for the sprinkler system designs of most nonstorage types of occupancy hazards
- Data Sheet 8-1, *Commodity Classification*, for the classification of most products that might be found in a general warehouse environment
- Data Sheet 8-9, *Storage of Class 1, 2, 3, 4 and Plastic Commodities*, for the sprinkler system designs of most storage occupancy hazards

## 2.2 Sprinkler System Types

### 2.2.1 General Recommendations for Sprinkler System Types

#### 2.2.1.1 Selection of Sprinkler System

2.2.1.1.1 See the relevant occupancy-specific data sheet to determine if there are any restrictions on the types of sprinkler systems available for installation.

2.2.1.1.2 When the relevant occupancy-specific data sheet recommends a specific sprinkler system type for installation, see the applicable subsection in Section 2.2 for recommendations pertaining to that sprinkler system.

2.2.1.1.3 When the occupancy-specific data sheet does not recommend a specific sprinkler system type for installation, see Sections 2.2.2 through 2.2.9 to determine which sprinkler systems are applicable for the area to be protected.

#### 2.2.1.2 Compatibility of Sprinkler System Components with the Environment

2.2.1.2.1 Ensure the materials chosen for the sprinkler system are compatible with the environment they will be protecting. See the *Approval Guide* for sprinkler system components that can be used in atypical environments, such as corrosive, low- or high-temperature environments.

#### 2.2.1.3 Recommended Sprinkler System Design and Hydraulic Calculations

2.2.1.3.1 See the relevant occupancy-specific data sheet for recommendations regarding the sprinkler system design for the area to be protected.

2.2.1.3.2 See Data Sheet 3-0, *Hydraulics of Fire Protection Systems*, for information related to the hydraulic calculation of a sprinkler system.

2.2.1.3.3 When the occupancy-specific data sheet does not provide guidance on the Hazen-Williams C-Value (roughness coefficient) to be used for hydraulic analysis of the sprinkler system, see the default values given in Table 2.2.1.3.3.

Table 2.2.1.3.3. Default Hazen-Williams C-Values for Sprinkler System Hydraulic Calculations

Sprinkler System Type	Type of Sprinkler Pipe	Special Conditions	Hazen-Williams C-Value
Wet	Black Steel	None	120
	Polymer Enhanced	None	140
	Plastic	None	150
Dry or Pre-Action	Black Steel	None	100
		The gaseous medium for the sprinkler system will be an inert gas, such as nitrogen	120
	Internally Galvanized	None	120
	Polymer Enhanced	None	140
Refrigerated-Area	Black Steel	None	100
		Ambient temperature always maintained at or below 20°F (-7°C)	120
		The gaseous medium for the sprinkler system will be an inert gas, such as nitrogen	120
	Internally Galvanized	None	120
	Polymer Enhanced	None	140
Vacuum	Black Steel	None	100
		Recommendations in Section 2.2.1.3.4 are met	120
		Ambient temperature always maintained at or below 20°F (-7°C)	120
	Internally Galvanized	None	120
	Polymer Enhanced	None	140

2.2.1.3.4 The default Hazen-Williams C-Value for a vacuum sprinkler system can be 120 when the sprinkler piping arrangement of the system meets all the following conditions:

- A. There is single-path flow (i.e., no loops or grids) throughout the sprinkler system, and
- B. When applicable, the water supply can meet the maximum recommended water delivery time, and
- C. The recommendations in Section 2.2.1.4 are satisfied, and
- D. The pipe connection method avoids the collection of water, and
- E. The sprinkler branch lines and mains are pitched to avoid water accumulation within the sprinkler system.

2.2.1.3.5 Post the sprinkler system's design criteria on a rigid placard installed at the system valve. At a minimum, include the following information:

- Name of the area protected by the sprinkler system
- Classification of the occupancy hazard
- Sprinkler's identification number(s) (i.e., SIN)
- Nominal temperature rating of the sprinklers
- Maximum area spacing of the sprinklers
- Number of sprinklers in the sprinkler system's design area
- Minimum sprinkler design pressure
- Flow and pressure required at the base of the riser
- Hose stream allowance
- Name of installing contractor

2.2.1.3.6 For antifreeze solution systems, see Section 2.2.8.3 for additional recommended information for the placard.

### 2.2.1.4 Sprinkler System Maximum Area of Coverage

2.2.1.4.1 The maximum area of coverage for a wet-type ceiling-level sprinkler system is limited only by:

- A. The hydraulic requirements of the sprinkler system's design and
- B. The waterflow alarm requirements in Section 2.3.3.

2.2.1.4.2 The maximum area of coverage for a dry-type ceiling-level sprinkler system is limited by:

- A. The hydraulic requirements of the sprinkler system's design and
- B. The water delivery time indicated in the sprinkler system's design.

2.2.1.4.3 The maximum area of coverage for an in-rack sprinkler system (wet or dry) is 40,000 ft<sup>2</sup> (3,715 m<sup>2</sup>) of floor area occupied by the racks, including aisles, regardless of the number of in-rack sprinkler levels.

### 2.2.1.5 Sprinkler System Piping Arrangements

2.2.1.5.1 The sprinkler system piping arrangement of a wet-pipe and deluge sprinkler system can be single-path flow, looped, or gridded.

2.2.1.5.2 Arrange the sprinkler piping of dry-pipe, preaction, refrigerated-area, or vacuum sprinkler system so that:

- A. There is single-path flow (i.e., no loops or grids) throughout the sprinkler system, and
- B. When applicable, the water supply can meet the maximum recommended water delivery time, and
- C. The recommendations in Section 2.2.1.4 are satisfied.

2.2.1.5.3 The feed main and/or cross main of dry-pipe and preaction sprinkler systems protecting a nonstorage occupancy can be looped.

### 2.2.1.6 Arrangement of Ceiling and In-Rack Sprinkler Systems

2.2.1.6.1 Arrange ceiling-level sprinkler systems and in-rack sprinkler systems as separate sprinkler systems equipped with their own check valves, control valves and waterflow alarms.

2.2.1.6.2 An in-rack sprinkler system can be fed from a ceiling-level sprinkler system when:

- A. The number of in-rack sprinklers to be fed does not exceed 20, and
- B. The water supply is capable of hydraulically providing the requirements of the ceiling and in-rack sprinkler demands, and
- C. A readily accessible separate control valve is provided on the supply main feeding the in-rack sprinklers from the ceiling-level sprinkler system.

### 2.2.1.7 Arranging Sprinkler Systems for Flushing

2.2.1.7.1 Arrange all sprinkler systems for flushing by providing removable fittings (i.e., flushing connections; see Appendix A for definition) at the end of all cross mains, near mains and far mains. The minimum diameter of the flushing connection is 1.25 in. (32 mm).

2.2.1.7.2 Arrange all branch lines on grid-type sprinkler systems to facilitate flushing by having one end of each branch line be detachable by means of a simple union or flexible joint (see Figure 2.2.1.7.2). Other arrangements that accomplish this goal, such as the installation of FM Approved branch line testers, are acceptable.

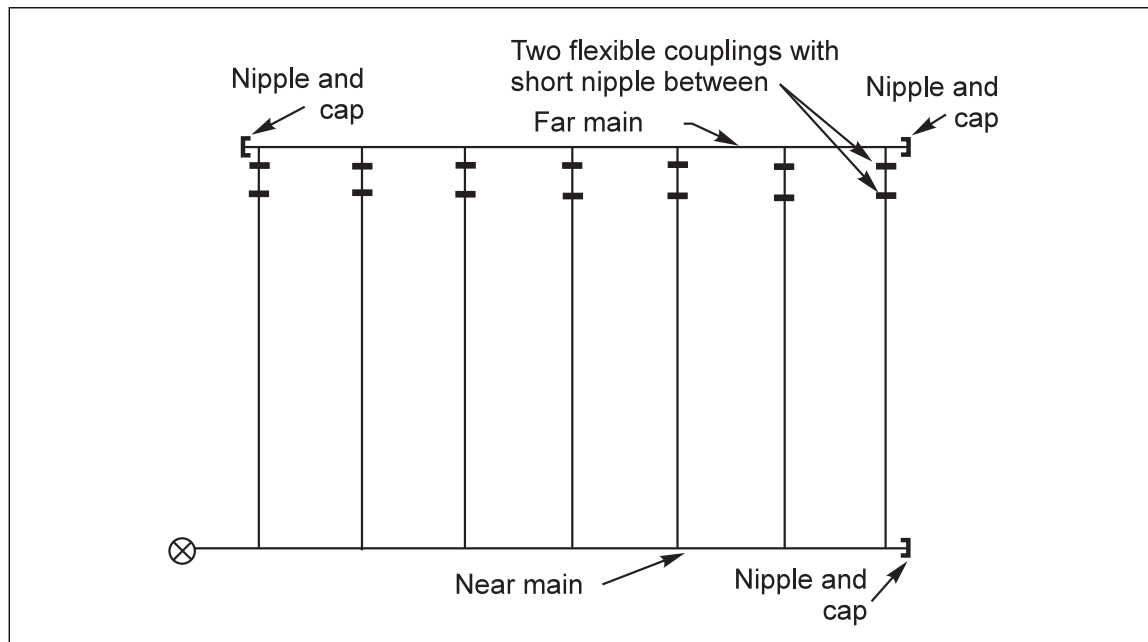

Fig. 2.2.1.7.2. An example of arranging grid-type sprinkler systems for flushing

### 2.2.1.8 Protection of Sprinkler Systems from Mechanical and/or Freeze Damage

2.2.1.8.1 Regardless of the sprinkler system type, protect the automatic system valve (alarm check, dry-pipe, etc.) servicing the sprinkler system from mechanical damage.

2.2.1.8.2 Adhere to the relevant recommendations in Data Sheet 9-18, *Protection Against Freeze-Ups*.

### 2.2.1.9 Additives and Chemicals for Sprinkler Systems

2.2.1.9.1 Do not use additives or chemicals intended to improve the performance of the sprinkler system unless they are FM Approved specifically for the intended purpose.

### 2.2.1.10 Gaseous Medium Supplies for Dry-Pipe and Preaction Sprinkler Systems

2.2.1.10.1 See Section 2.2.5.4 for the gaseous medium supply for a refrigerated-area sprinkler system.

2.2.1.10.2 For maintaining internal pressure within a dry-pipe or preaction sprinkler system, use an inert gaseous medium, such as nitrogen, or a gaseous medium that is FM Approved specifically for the occupancy hazard application. Ensure the inert gaseous medium used in the sprinkler system is compatible with all sprinkler system components.

2.2.1.10.3 The use of air as a gaseous medium for maintaining internal pressure within a dry-pipe or preaction sprinkler system is an acceptable alternative to an inert gaseous medium when:

- A. A regenerative air dryer is provided on the air supply line to the sprinkler system, or
- B. The sprinkler system feeds a maximum of 20 sprinklers

2.2.1.10.4 Arrange the gaseous medium supply so it is always available for the dry-pipe sprinkler system in accordance with the dry-pipe valve manufacturer's specifications.

2.2.1.10.5 Ensure the gaseous medium supply maintained on site is reliable (see Appendix A for definition of a reliable gaseous medium supply), such as when supplied from an FM Approved nitrogen generator, and can fill the dry-pipe or preaction sprinkler system up to the minimum required system maintenance pressure within 30 minutes, but is also arranged to:

- A. Allow the dry-pipe or preaction sprinkler system to meet the maximum recommended water delivery time per Section 2.2.1.11, and

B. Not exceed the maximum recommended gaseous medium pressure maintained in the sprinkler system.

2.2.1.10.6 Install a check valve on the connection between the gaseous medium supply and the dry-pipe or preaction sprinkler system.

2.2.1.10.7 Install a relief valve between the gaseous medium supply and the sprinkler system arranged to relieve at 5 psi (0.3 bar) above the maximum recommended gaseous medium pressure maintained within the sprinkler system.

### 2.2.1.11 Water Delivery Times for Dry Pipe, Preaction, Refrigerated-Area, Vacuum, and Deluge Sprinkler Systems

2.2.1.11.1 See the relevant occupancy-specific data sheet for the maximum recommended water delivery time. Except for a deluge sprinkler system, when a maximum water delivery time is not specified, use one of the following:

- A. 60 seconds with the operation of the single most remote sprinkler, or
- B. 50 seconds with the operation of the most remote 2 sprinklers on the most remote branch line for nonstorage type occupancy hazards, or
- C. For obstructed ceiling construction, 40 seconds with the operation of the most remote 2 sprinklers on the most remote branch line for storage type occupancy hazards, or
- D. For unobstructed ceiling construction, 40 seconds with the operation of the most remote 2 sprinklers on the most remote 2 branch lines (4 sprinklers total).

2.2.1.11.2 See the relevant occupancy-specific data sheet for the maximum recommended water delivery time of the deluge sprinkler system. If a maximum water delivery time is not specified in the data sheet, use a maximum water delivery time of 30 seconds.

2.2.1.11.3 To achieve the maximum water delivery times indicated in Section 2.2.1.11.1, experience has demonstrated that the size of the sprinkler system needs to be limited to approximately 10,000 ft<sup>2</sup> to 12,000 ft<sup>2</sup> (930 m<sup>2</sup> to 1,115 m<sup>2</sup>). Clients of FM should validate the maximum water delivery time before the start of any work by submitting copies of all plans, calculations, water supply details, and equipment details to the local FM service office. Specific details needed for this evaluation include:

- A. Manufacturer and model designation for the dry-pipe, and
- B. Air pressure to be maintained within the sprinkler piping, and
- C. Computer calculations showing that the maximum recommended water delivery times are being met.

2.2.1.11.4 See Section 2.3.4 for information regarding the inspector's test connection if the water delivery time is based on the operation of more than one sprinkler.

### 2.2.1.12 Activation of Preaction, Refrigerated-Area, Vacuum, and Deluge

Install FM Approved fire detection (heat or smoke) and FM Approved fire alarm control panels used to activate a preaction, refrigerated-area, vacuum, or deluge sprinkler system in accordance with Data Sheet 5-48, *Automatic Fire Detection*, the occupancy-specific data sheet (when applicable), and the following recommendations.

#### 2.2.1.12.1 Fire Alarm Control Panel Release of Preaction, Refrigerated-Area, Vacuum, and Deluge Sprinkler Systems

2.2.1.12.1.1 Use a preaction valve, solenoid valve, and automatic-release panel combination that is FM Approved as a compatible automatic sprinkler system. Ensure its application, along with the chosen detection system, is in accordance with its listing in the *Approval Guide*.

2.2.1.12.1.2 Provide one fire alarm control panel for each preaction, refrigerated-area, vacuum, and deluge sprinkler system.

2.2.1.12.1.3 A single fire alarm control panel can be used to activate more than one sprinkler system if the fire alarm control panel is capable of:

- A. Initiating each sprinkler system from its own automatic releasing module for preaction, refrigerated-area, vacuum, and deluge sprinkler systems compatible with the fire alarm control panel, and

- B. Each automatic releasing module can be independently isolated and supervised, and
- C. The battery back-up is sized to provide 90 hours of power for each sprinkler system that is connected to the panel.

2.2.1.12.1.4 Arrange preaction systems to be activated both automatically and manually. Provide a readily accessible means for the preaction or deluge valve to be manually activated during a fire.

2.2.1.12.1.5 Do not arrange the vacuum sprinkler system to fail-safe open in the event of excessive vacuum pressure loss when arranged for either a single-interlock or double-interlock system setting.

#### **2.2.1.12.2 Activation of Praction, Refrigerated-Area, Vacuum, and Deluge Sprinkler Systems by Heat Detection**

2.2.1.12.2.1 General Recommendations for Activation of Praction, Refrigerated-Area, Vacuum, and Deluge Sprinkler Systems by Heat Detection

- A. See the occupancy-specific data sheet to see if guidance pertaining to the specific type of heat detection, horizontal spacing, and vertical positioning of the detection has been provided.
- B. Unless indicated otherwise in the occupancy-specific data sheet, install fixed-temperature, rate-of-rise, or combination fixed-temperature/rate of-rise heat detection.
- C. The installation of flame detection is recommended only when specially allowed by the applicable occupancy-specific data sheet.
- D. In refrigerated-area sprinkler systems, install fixed-temperature heat detection only. Do not use pilot sprinklers in a refrigerated-area sprinkler system. When the heat detection system is pneumatic, use a gaseous medium for the detection system that will be independent from the gaseous medium that is being used for the sprinkler system.
- E. Use single-zone, Class A circuitry for fire detection devices.
- F. Provide separate detection systems for each sprinkler system.

2.2.1.12.2.2 Spacing and Location of Heat Detection for Activation of Praction, Refrigerated-Area, and Vacuum Sprinkler Systems

##### **A. Ceiling-Level Heat Detection Under Unobstructed Ceiling Construction**

1. For ceilings with smooth unobstructed ceiling construction, install the heat detection not to exceed the maximum allowable spacing of the specific heat detection in the *Approval Guide* listing.
2. For ceilings with non-smooth unobstructed ceiling construction, install the heat detection such that:
  - a. The linear spacing does not exceed 50% of the maximum allowable linear spacing indicated in the *Approval Guide* for the specific heat detection to be installed, or
  - b. The linear spacing of the heat detection is the same as the ceiling sprinklers.
3. When pilot sprinklers are used, install them on the same horizontal spacing and vertical location as the ceiling sprinklers.
4. See Section 2.2.1.12.2.3(B) if a single-interlock preaction sprinkler system is being installed and a wet sprinkler system design is desired.

##### **B. Ceiling-Level Heat Detection Under Obstructed Ceiling Construction**

1. Install the heat detection in every channel formed by the ceiling's structural members. Provide spacing of the heat detection within each channel in accordance with its listing in the *Approval Guide*.
2. The heat detection does not need to be installed in every channel formed by the ceiling's structural members when:
  - a. The ceiling sprinklers are not required in every channel formed by the ceiling's structural members, and
  - b. The heat detection is installed on the same horizontal spacing and vertical location as the ceiling sprinklers.

3. When pilot sprinklers are used, install them on the same horizontal spacing and vertical location as the ceiling sprinklers.
4. See Section 2.2.1.12.2.3(B) if a single-interlock preaction sprinkler system is being installed and a wet sprinkler system design is desired.

#### C. Heat Detection for the Activation of In-Rack Sprinklers

1. Install heat detection for the activation of in-rack sprinklers using the same horizontal spacing and vertical location of the in-rack sprinklers.
2. The ceiling-level heat detection system can be used to activate both the ceiling and in-rack sprinkler systems of a refrigerated-area sprinkler system when all the following conditions are met:
  - a. The storage height does not exceed 35 ft (10.7 m), and
  - b. The ceiling height does not exceed 40 ft (12.2 m), and
  - c. The commodity classification does not exceed Class 3, and
  - d. The storage arrangement qualifies as open-frame racks, and
  - e. The ceiling and in-rack sprinkler systems are fed by the same refrigerated-area sprinkler system, but are equipped with separate accessible indicating control valves, and
  - f. The ceiling heat detection is arranged in accordance with Section 2.2.1.12.2.3(B), based on the ceiling construction type present, and
  - g. The maximum water delivery time for both the ceiling and the in-rack sprinkler systems, as specified in the occupancy-specific data sheet, can be achieved.

#### 2.2.1.12.2.3 Allowable Sprinkler System Designs Based on Heat Detection Arrangement

- A. For ceiling and in-rack sprinkler system design purposes, use the sprinkler system design indicated for a dry-pipe sprinkler system from the applicable occupancy-specific data sheet when preaction, refrigerated-area, and vacuum sprinkler systems are installed.
- B. For ceiling sprinkler system design purposes (this does not apply to in-rack sprinkler systems), a wet-pipe sprinkler system design can be used for a single-interlock preaction sprinkler system or a single-interlock vacuum sprinkler system when:
  1. For ceilings with smooth unobstructed ceiling construction, the linear spacing of the heat detection (does not apply to pilot sprinklers) does not exceed 50% of the maximum allowable linear spacing indicated in the *Approval Guide* for the specific heat detection to be installed, or
  2. For ceilings with non-smooth unobstructed ceiling construction, the horizontal spacing of the heat detection (does not apply to pilot sprinklers) does not exceed the spacing of the ceiling sprinklers, or
  3. For ceilings with obstructed ceiling construction, heat detection is installed in every channel formed by the ceiling's structural members and the horizontal distance between any spot type heat detection does not exceed 50% of the maximum allowable linear spacing indicated in the *Approval Guide* for the specific heat detection to be installed, or
  4. The heat detection is installed on the same horizontal spacing and vertical location as the ceiling sprinklers.

#### 2.2.1.12.3 Activation of Preaction, Refrigerated-Area, and Vacuum Sprinkler Systems by Smoke Detection

##### 2.2.1.12.3.1 General Recommendations for Activation of Preaction, Refrigerated-Area, Vacuum, and Deluge Sprinkler Systems by Smoke Detection

- A. Do not use smoke detection to activate a preaction, refrigerated-area, vacuum, or deluge sprinkler system unless the occupancy-specific data sheet indicates that smoke detection is permissible for the area being protected.

B. Where the occupancy-specific data sheet permits the use of smoke detection to activate a refrigerated-area sprinkler system, use smoke detection that is listed in the *Approval Guide* under the heading *Fire Detection, Smoke-Actuated, Protection of Refrigerated Spaces*.

C. Arrange the protection system's fire alarm control panel to activate an alarm for all sprinkler systems (both ceiling as well as in-rack sprinkler systems) located within the protected area.

D. When applicable for the smoke detection device being installed, use single-zone, Class A circuitry for detection devices.

#### 2.2.1.12.3.2 Spacing and Location of Smoke Detection for Activation of Preaction, Refrigerated-Area, and Vacuum Sprinkler Systems

##### A. Ceiling-Level Smoke Detection Under Unobstructed Ceiling Construction

1. For ceilings with smooth unobstructed ceiling construction, the maximum allowable linear spacing is 30 ft (9.1 m).
2. For ceilings with non-smooth unobstructed ceiling construction, the maximum allowable linear spacing is 15 ft (4.6 m).
3. See Section 2.2.1.12.3.3(B) if a single-interlock preaction sprinkler system is being installed and a wet sprinkler system design is desired.

##### B. Ceiling-Level Smoke Detection Under Obstructed Ceiling Construction

1. Install the smoke detection in every channel formed by the ceiling's structural members.
2. The maximum allowable linear spacing of the smoke detection within each channel is:
  - a. 30 ft (9.1 m) if the ceiling is smooth, or
  - b. 15 ft (4.6 m) if the ceiling is not smooth.

##### C. Smoke Detection for the Activation of In-Rack Sprinklers

1. Install smoke detection for the activation of in-rack sprinklers using the same horizontal spacing and vertical location of the in-rack sprinklers.
2. The ceiling-level smoke detection system can be used to activate both the ceiling and in-rack sprinkler systems of a refrigerated-area sprinkler system when all the following conditions are met:
  - a. The maximum storage height is 35 ft (10.7 m), and
  - b. The maximum ceiling height is 40 ft (12.2 m), and
  - c. The maximum hazard of storage is Class 3, and
  - d. The storage arrangement qualifies as open-frame racks, and
  - e. The ceiling and in-rack sprinkler systems are fed by the same refrigerated-area sprinkler system, but are equipped with separate accessible indicating control valves, and
  - f. The ceiling meets the guidelines for smooth, unobstructed ceiling construction, and
  - g. The maximum linear spacing of the ceiling smoke detection is 15 ft (4.6 m), and
  - h. The maximum water delivery time for both the ceiling and the in-rack sprinkler systems, as specified in the occupancy-specific data sheet, can be achieved.

#### 2.2.1.12.3.3 Allowable Sprinkler System Designs Based on Smoke Detection Arrangement

A. For ceiling and in-rack sprinkler system design purposes, use the sprinkler system design indicated for a dry-pipe sprinkler system from the applicable occupancy-specific data sheet when preaction, refrigerated-area, and vacuum sprinkler systems are installed.

B. For ceiling sprinkler system design purposes (this does not apply to in-rack sprinkler systems), a wet-pipe sprinkler system design can be used for a single-interlock preaction sprinkler system or a single-interlock vacuum sprinkler system when:

1. The ceiling is smooth, unobstructed ceiling construction, and

2. The maximum linear spacing of the smoke detection is 15 ft (4.6 m).

## 2.2.2 Wet-Pipe Sprinkler Systems

### 2.2.2.1 General Recommendations for Wet-Pipe Sprinkler Systems

See Section 2.2.1 for general recommendations that apply to wet-pipe sprinkler systems.

### 2.2.2.2 Recommended Ambient Temperature Conditions for Wet-Pipe Sprinkler Systems

2.2.2.2.1 Use wet-pipe sprinkler systems only in areas where the ambient temperature of the protected area will always be between 40°F (4°C) and 200°F (95°C).

### 2.2.2.3 Sprinklers for Wet-Pipe Sprinkler Systems

2.2.2.3.1 Pendent, sidewall, and upright type sprinklers (standard-coverage and extended-coverage) can be installed on a wet-pipe sprinkler system.

2.2.2.3.2 Dry-pendent, dry-sidewall, and dry-upright sprinklers (standard-coverage and extended-coverage) can be installed on a wet-pipe sprinkler system when the portions of the sprinkler system connected to the dry-type sprinklers are safeguarded against freezing in accordance with the dry-type sprinkler manufacturer's installation guidelines.

## 2.2.3 Dry-Pipe Sprinkler Systems

### 2.2.3.1 General Recommendations for Dry-Pipe Sprinkler Systems

See Section 2.2.1 for general recommendations that apply to dry-pipe sprinkler systems.

### 2.2.3.2 Recommended Ambient Temperature Conditions for Dry-Pipe Sprinkler Systems

2.2.3.2.1 Dry-pipe sprinkler systems are acceptable when:

- A. The ambient temperature of the protected area can drop below 40°F (4°C), or
- B. The ambient temperature of the protected area can rise above 200°F (95°C).

2.2.3.2.2 Install a refrigerated-area sprinkler system per Section 2.2.5, instead of a dry pipe sprinkler system, when:

- A. The ambient temperature of the protected area will always be below 20°F (-7°C), and
- B. The occupancy of the protected area is storage.

2.2.3.2.3 Ensure the components of the sprinkler system are compatible with the expected ambient temperatures.

### 2.2.3.3 Sprinklers for Dry-Pipe Sprinkler Systems

2.2.3.3.1 Install only upright or dry-type sprinklers (dry-upright or dry-sidewall) on a dry-pipe sprinkler system.

2.2.3.3.2 Unless indicated otherwise in the relevant occupancy-specific data sheet, install standard-response, nominal 280°F (140°C) rated sprinklers on a dry-pipe sprinkler system.

2.2.3.3.3 See the relevant occupancy-specific data sheet for any additional recommendations.

### 2.2.3.4 System Valve in Combination With Other System or Check Valves

2.2.3.4.1 Do not install other system valves (such as preaction or deluge valves) or check valves in the waterway downstream of the dry-pipe valve.

### 2.2.3.5 Excessive Water Accumulation Above Dry-Pipe Valve Clappers

2.2.3.5.1 Provide an automatic high-water level signaling device or an automatic drain device for any dry-pipe valve where an unacceptable level of water can accumulate above the clapper, such as with a low-differential dry-pipe valve.

### 2.2.3.6 Accelerators for Dry-Pipe Sprinkler Systems

2.2.3.6.1 When installing an accelerator on a dry-pipe sprinkler system, ensure the *Approval Guide* indicates the accelerator is compatible for the specific dry-pipe valve being used.

2.2.3.6.2 Follow the manufacturer's installation guidelines for the specific accelerator being installed. Ensure the following conditions are met:

- A. Locate the connection of the accelerator to the riser above the point at which water (priming water and back drainage) is expected when the dry-pipe valve and the accelerator are set. However, this connection is not required when the design features of the chosen accelerator prevent submergence of the restriction orifice as well as other operating parts of the accelerator.
- B. Install an indicating control valve and an FM Approved anti-flooding device between the riser and the accelerator. However, an anti-flooding device is not required when using FM Approved accelerators with built-in anti-flooding devices.
- C. Install a check valve between the accelerator and the intermediate chamber of the dry-pipe valve. An indicating valve may be installed in place of the check valve if the accelerator requires pressure feedback.
- D. A check valve between the accelerator and the intermediate chamber of the dry-pipe valve is not needed if:
  - 1. FM Approved accelerators with built-in anti-flooding devices are installed, or
  - 2. FM Approved accelerators that are not expected to flood are installed.

### 2.2.4 Preaction Sprinkler Systems

#### 2.2.4.1 General Recommendations for Preaction Sprinkler Systems

See Section 2.2.1 for general recommendations that apply to preaction sprinkler systems.

#### 2.2.4.2 Recommended Ambient Temperature Conditions for Preaction Sprinkler Systems

2.2.4.2.1 Preaction sprinkler systems are acceptable when:

- A. The ambient temperature of the protected area can drop below 40°F (4°C) or,
- B. The ambient temperature of the protected area can rise above 200°F (95°C), or,
- C. The ambient temperature of the protected area is between 40°F (4°C) and 200°F (95°C), provided that a single-interlock, preaction sprinkler system is installed using an activating detection arrangement in accordance with Section 2.2.1.12.

2.2.4.2.2 Install a refrigerated-area sprinkler system when:

- A. The ambient temperature of the protected area will always be maintained below 20°F (-7°C), and
- B. The occupancy of protected area is storage.

2.2.4.2.3 Ensure the components of the preaction sprinkler system are compatible with the expected ambient temperatures.

#### 2.2.4.3 Sprinklers for Preaction Sprinkler Systems

2.2.4.3.1 Install only upright or dry-type sprinklers (dry-pendent, dry-upright, or dry-sidewall sprinklers) on preaction sprinkler systems.

2.2.4.3.2 Pendent sprinklers can be installed on a preaction sprinkler system if the protected area is not subject to freezing and the inside of the sprinkler pipe is either galvanized-coated (or equivalent coating), or is provided with an inert gaseous medium, such as nitrogen, per Section 2.2.1.10.

2.2.4.3.3 Unless indicated otherwise in the relevant occupancy-specific data sheet, install standard-response, nominal 280°F (140°C) rated sprinklers on a preaction sprinkler system.

2.2.4.3.4 Unless indicated otherwise in the relevant occupancy-specific data sheet, install nominal 160°F (70°C) rated sprinklers when a single-interlock preaction sprinkler system can be treated as a wet-pipe sprinkler system for design purposes.

2.2.4.3.5 See the relevant occupancy-specific data sheet for any potential additional recommendations.

#### 2.2.4.4 System Valve in Combination with Other System or Check Valves

2.2.4.4.1 Do not install other system valves (such as dry-pipe or deluge valves) or check valves in the waterway downstream of the preaction valve.

### 2.2.5 Refrigerated-Area Sprinkler Systems

#### 2.2.5.1 General Recommendations for Refrigerated-Area Sprinkler Systems

2.2.5.1.1 See Section 2.2.1 for general recommendations that apply to refrigerated-area sprinkler systems.

2.2.5.1.2 Install a refrigerated-area sprinkler system in accordance with the recommendations indicated for a double-interlock preaction sprinkler system in Section 2.2.4 except as modified or supplemented with the recommendations provided in Section 2.2.5.

#### 2.2.5.2 Recommended Ambient Temperature Conditions for Refrigerated-Area Sprinkler Systems

2.2.5.2.1 Refrigerated-area sprinkler systems are acceptable when:

- A. The ambient temperature of the protected area will always be maintained below 20°F (-7°C), and
- B. The occupancy of protected area is storage.

2.2.5.2.2 Ensure the components of the sprinkler system are compatible with the expected ambient temperatures.

#### 2.2.5.3 Sprinkler Riser Arrangement for Refrigerated-Area Sprinkler Systems

2.2.5.3.1 See Figure 2.2.5.3.1 for an example of the riser piping arrangement of a refrigerated-area sprinkler system.

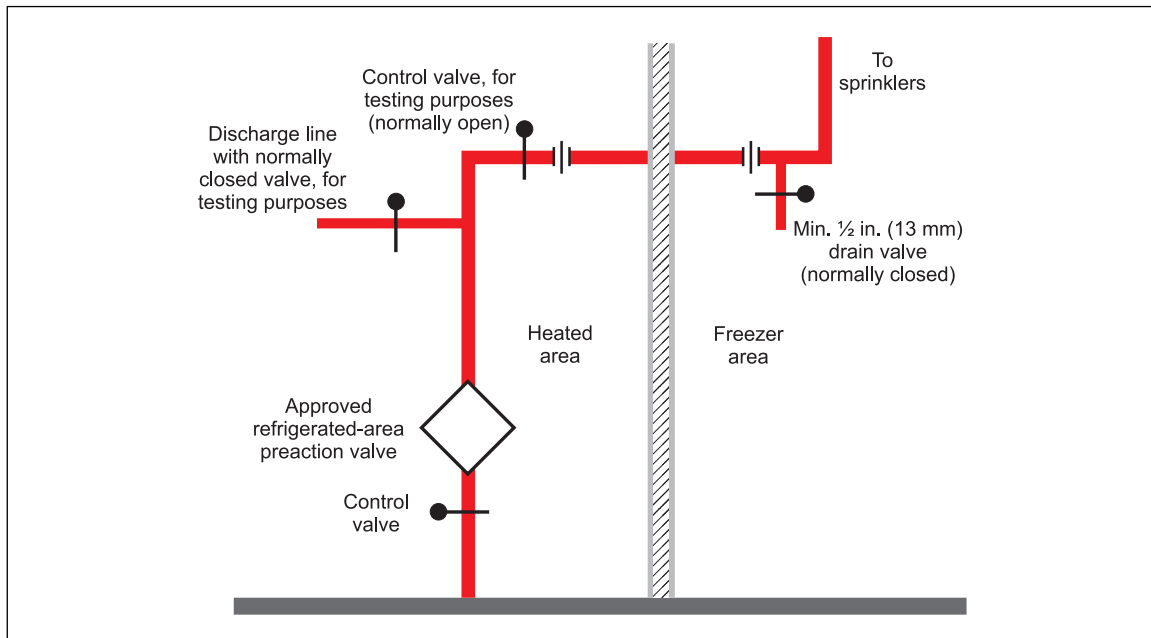

Fig. 2.2.5.3.1. Example of a sprinkler riser arrangement for a refrigerated-area sprinkler system

2.2.5.3.2 Arrange the feed main sprinkler piping so it can be easily disassembled at the point where it passes from the heated space to the cold space to allow for inspection of ice plug formation as shown in Figure 2.2.5.3.1.

2.2.5.3.3 For testing purposes, provide each refrigerated-area sprinkler system riser with a 2 in. (50 mm) diameter trip test discharge line equipped with a normally closed valve as well as a normally open trip test control valve installed downstream of the trip test discharge line as shown in Figure 2.2.5.3.1.

### 2.2.5.4 Gaseous Medium Supplies for Refrigerated-Area Sprinkler Systems

2.2.5.4.1 Use an inert gaseous medium, such as nitrogen, or a gaseous medium that is FM Approved specifically for the occupancy hazard application, for maintaining internal pressure within a refrigerated-area sprinkler system. Ensure the inert gaseous medium used in the refrigerated-area sprinkler system is compatible with all sprinkler system components.

2.2.5.4.2 The use of air as a gaseous medium for maintaining internal pressure within a refrigerated-area sprinkler system is an acceptable alternative to an inert gaseous medium when an adequately sized FM Approved dry air unit system for a refrigerated-area sprinkler system is provided. Arrange the air intake for compressed air as follows:

- A. The air is taken from the protected area, or
- B. The air can be taken from room temperature air when the dry air unit system has been tested with air intake at room temperature and the pressure dew point can be maintained 20°F (11°C) lower than the ambient temperature of the protected area.

2.2.5.4.3 The use of air as a gaseous medium for maintaining internal pressure within a refrigerated-area sprinkler system is an acceptable alternative to an inert gaseous medium when an adequately sized dehydrator or regenerative air dryer is provided on the air supply line to the sprinkler system as demonstrated in Figure 2.2.5.4.3. Ensure the following:

- A. The air intake line from the protected area to the air compressor and tank is in accordance with the equation shown in Figure 2.2.5.4.3, and
- B. The dry air feed to the sprinkler system is connected to the sprinkler's feed main in the protected area through separate duplex lines that can be easily removed for inspection and removal of any ice accumulations, and
- C. The duplex lines are arranged so that the diameter of each line provides a minimum exposed exterior surface area of 0.7 ft<sup>2</sup>/scfm (0.038 m<sup>2</sup>/(m<sup>3</sup>/h)), and
- D. The minimum length of each duplex line is at least 30 times the line's nominal diameter, and
- E. The dry air feed line connects to the sprinkler system's feed main via a return bend equipped with a check valve.

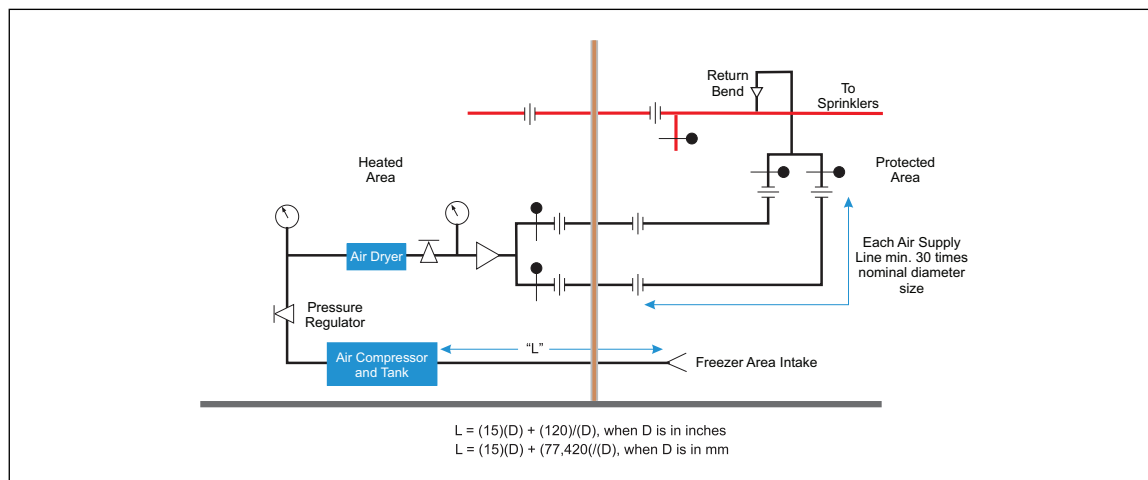

Fig. 2.2.5.4.3. Piping arrangement when using air as the gaseous medium for a refrigerated-area sprinkler system

2.2.5.4.4 If a regenerative air dryer is used, arrange the dryer so that its pressure dew point is 20°F (11°C) lower than the ambient temperature of the protected area.

2.2.5.4.5 Arrange the gaseous medium supply so it is always available for the refrigerated-area sprinkler system in accordance with the preaction valve manufacturer's specifications.

2.2.5.4.6 Ensure the gaseous medium supply maintained on site is reliable (see Appendix A for definition of reliable gaseous medium supply), such as when supplied from an FM Approved nitrogen generator, and can fill the refrigerated-area sprinkler system up to the minimum required system maintenance pressure within 30 minutes, but is also arranged to:

A. Allow the sprinkler system to meet the maximum recommended water delivery time per Section 2.2.1.11, and

B. Not exceed the maximum recommended gaseous medium pressure maintained in the sprinkler system.

2.2.5.4.7 Install a check valve on the connection between the gaseous medium supply and the refrigerated-area sprinkler system.

2.2.5.4.8 Install a relief valve between the gaseous medium supply and the sprinkler system arranged to relieve at 5 psi (0.3 bar) above the maximum recommended gaseous medium pressure maintained within the sprinkler system.

## 2.2.6 Vacuum Sprinkler Systems

### 2.2.6.1 General Recommendations for Vacuum Sprinkler Systems

2.2.6.1.1 See Section 2.2.1 for general recommendations that apply to vacuum sprinkler systems.

2.2.6.1.2 Install a vacuum sprinkler system in accordance with the recommendations indicated for a preaction sprinkler system in Section 2.2.4 except as modified or supplemented with the recommendations provided in Section 2.2.6.

### 2.2.6.2 Ceiling-Level Sprinklers for Vacuum Sprinkler Systems

2.2.6.2.1 Install only upright or dry-type sprinklers (dry-pendent, dry-upright, or dry-sidewall sprinklers) on a vacuum sprinkler system that are FM Approved specifically for vacuum sprinkler systems. In addition, pendent sprinklers that are FM Approved specifically for vacuum sprinkler systems can be installed on a vacuum sprinkler system when the ambient temperature of the protected area will always be maintained at or above 40°F (4°C).

2.2.6.2.2 Unless indicated otherwise in the relevant occupancy-specific data sheet, install standard-response, nominal 280°F (140°C) rated sprinklers when the sprinkler system is treated as a dry-pipe sprinkler system for design purposes.

2.2.6.2.3 Unless indicated otherwise in the relevant occupancy-specific data sheet, install nominal 160°F (70°C) rated sprinklers when the sprinkler system is treated as a wet-pipe sprinkler system for design purposes.

2.2.6.2.4 See the relevant occupancy-specific data sheet for additional recommendations.

## 2.2.7 Deluge Sprinkler Systems

### 2.2.7.1 General Recommendations for Deluge Sprinkler Systems

2.2.7.1.1 See Section 2.2.1 for general recommendations that apply to deluge sprinkler systems.

2.2.7.1.2 Install a deluge sprinkler system in accordance with the recommendations indicated for a preaction sprinkler system in Section 2.2.4 except as modified or supplemented with the recommendations in Section 2.2.7.

### 2.2.7.2 Sprinklers for Deluge Sprinkler Systems

2.2.7.2.1 Use FM Approved sprinklers that have had the sprinkler's thermal element and the orifice cap removed and are recommended for the hazard being protected, or FM Approved open spray nozzles that are recommended for the hazard being protected.

### 2.2.7.3 Sprinkler Piping Arrangement for Deluge Sprinkler Systems

2.2.7.3.1 Ensure the sprinkler piping arrangement of a deluge sprinkler system can meet:

- A. The sprinkler system's maximum recommended water delivery time, and
- B. The recommendations in Section 2.2.1.4.

### 2.2.8 Antifreeze Solution Sprinkler Systems

#### 2.2.8.1 General Recommendations for Antifreeze Solution Sprinkler Systems

2.2.8.1.1 Use an FM Approved antifreeze solution for all applications covered in Section 2.2.8 in accordance with its listing in the *Approval Guide*. See Section 2.2.8.2 if an FM Approved antifreeze solution is not available for the occupancy hazard or the ambient temperature conditions.

2.2.8.1.2 Unless indicated by the relevant occupancy-specific data sheet, treat the antifreeze solution sprinkler system as a wet-pipe sprinkler system for design purposes.

2.2.8.1.3 Ensure all the components of the antifreeze solution sprinkler system are compatible with the antifreeze solution being used.

#### 2.2.8.2 Non-FM Approved Antifreeze Solutions

2.2.8.2.1 When an FM Approved antifreeze solution is not available, unless the guidelines in Sections 2.2.8.2.2 through 2.2.8.2.5 apply, install either a dry-pipe, preaction, or refrigerated-area type sprinkler system, depending on the ambient temperature conditions.

2.2.8.2.2 If the size of the protected area does not exceed 2,000 ft<sup>2</sup> (185 m<sup>2</sup>), such as a small loading dock or a walk-in cooler, the use of a non-FM Approved antifreeze solution sprinkler system is acceptable. See Table 2.2.8.2.2 to determine the non-FM Approved antifreeze solutions that are considered acceptable, as well as the recommended antifreeze solution concentration for the maximum lowest expected ambient temperature in the protected area.

Table 2.2.8.2.2. Acceptable Non-FM Approved Antifreeze Solutions and the Recommended Concentration Levels for Conditions Outlined in Section 2.2.8.2

Antifreeze Solution	Concentration Percentage (by Volume in Water) <sup>1</sup>	Lowest Ambient Temperature of the Protected Area, °F (°C)
Diethylene Glycol	50	0 (-18)
	55	-15 (-26)
	60	-30 (-35)
Ethylene Glycol	39	0 (-18)
	44	-10 (-23)
	49	-20 (-29)
	53	-30 (-35)
Glycerin (C.P. or U.S.P. 96.5) <sup>2</sup>	40	15 (-10)
	50	0 (-18)
	60	-20 (-29)
	70	-30 (-35)
Propylene Glycol	30	20 (-7)
	40	5 (-15)
	50	-15 (-26)
	60	-50 (-46)

Note 1. See Data Sheet 2-81, *Fire Safety Inspections and Sprinkler System Maintenance*, for specific gravity measurements.  
 Note 2. C.P. = chemically pure; U.S.P. = United States Pharmacopoeia.

2.2.8.2.3 Where the size of the protected area will exceed 2,000 ft<sup>2</sup> (185 m<sup>2</sup>), the use of a non-FM Approved antifreeze solution sprinkler system is acceptable when:

A. The ambient temperature of the protected area will always be maintained at or above 32°F (0°C). For this condition use either a propylene glycol solution ranging between 20% and 25%, or a glycerin solution ranging between 30% and 35%, or

B. The ambient temperature of the protected area will always be maintained at or above 25°F (-4°C). For this condition use either a propylene glycol solution ranging between 25% and 30%, or a glycerin solution ranging between 35% and 40%.

2.2.8.2.4 Pre-mix the antifreeze solution and validate its concentration percentage before introducing it into the sprinkler system.

2.2.8.2.5 For any antifreeze solution that will be connected to a potable water supply, use only those antifreeze solutions that are acceptable to the authority having jurisdiction.

### 2.2.8.3 Documentation of Antifreeze Solution Sprinkler Systems

2.2.8.3.1 Install a placard on the antifreeze solution sprinkler system that lists the type, percent concentration, and volume of antifreeze solution required for the sprinkler system. Also include the lowest ambient temperature the antifreeze solution was designed for.

### 2.2.8.4 Sprinkler Piping Arrangement of Antifreeze Solution Sprinkler Systems

2.2.8.4.1 If the antifreeze solution sprinkler system is fed from a potable water supply, arrange the supply piping, backflow preventer, and expansion chamber in accordance with Figure 2.2.8.4.1.

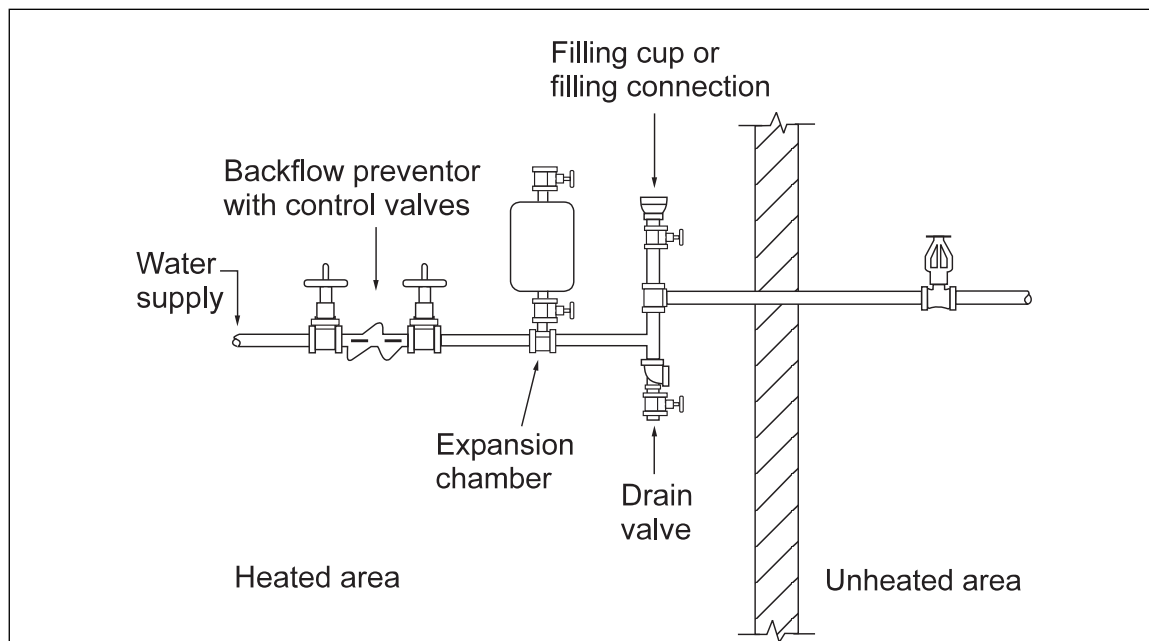

Fig. 2.2.8.4.1. Antifreeze solution sprinkler system piping arrangements connected to a potable water supply

2.2.8.4.2 Size the expansion chamber to account for 1.5 times the maximum expected thermal expansion of the antifreeze solution for the anticipated maximum and minimum ambient temperatures. Ensure the expansion chamber is compatible with the antifreeze solution.

2.2.8.4.3 If the antifreeze solution sprinkler system is fed from a non-potable water supply, do one of the following options:

- A. Arrange the supply piping and valves in accordance with Figure 2.2.8.4.1, or
- B. Arrange the supply piping and valves in accordance with Figure 2.2.8.4.1, but replace the indicated backflow preventer with a check valve equipped with a 1/32 in. (0.8 mm) hole in the clapper. The expansion tank is optional with this arrangement.

### 2.2.9 Exposure-Protection Sprinkler Systems

2.2.9.1 Follow the recommendations for dry-pipe sprinkler systems in Section 2.2.3 for an exposure-protection sprinkler system that uses either closed-type sprinklers or automatic spray nozzles, and where the system is activated in the same manner as a dry-pipe sprinkler system.

2.2.9.2 Follow the recommendations for preaction sprinkler systems in Section 2.2.4 for an exposure-protection sprinkler system that uses either closed-type sprinklers or automatic spray nozzles, and where the system is activated in the same manner as a preaction sprinkler system.

2.2.9.3 Follow the recommendations for deluge sprinkler systems in Section 2.2.7 for an exposure-protection sprinkler system that uses either open-type sprinklers or open spray nozzles.

2.2.9.4 Check the *Approval Guide* to ensure the sprinklers chosen for the exposure-protection sprinkler system are FM Approved for the hazard they are intended to mitigate.

### 2.3 Sprinkler System Components

#### 2.3.1 Control Valves

2.3.1.1 Install at least one control valve for every sprinkler system.

2.3.1.2 Arrange all control valves so they are readily accessible and operable during a fire, and for any testing, inspection, and maintenance requirements, in accordance with the following (in order of preference):

- A. Outdoors greater than or equal to 40 ft (12 m) from the building or area they serve.
- B. Outdoors less than 40 ft (12 m) from the building or area they serve.
- C. Outdoors using wall post indicator valves located along a minimum 1-hour rated exterior wall.
- D. Indoors in a room with minimum one hour fire-rated construction that is directly accessible via an exterior door.
- E. Indoors within an area that is protected by a different sprinkler system.

See Figure 2.3.1.2 for a visual demonstration of these arrangements.

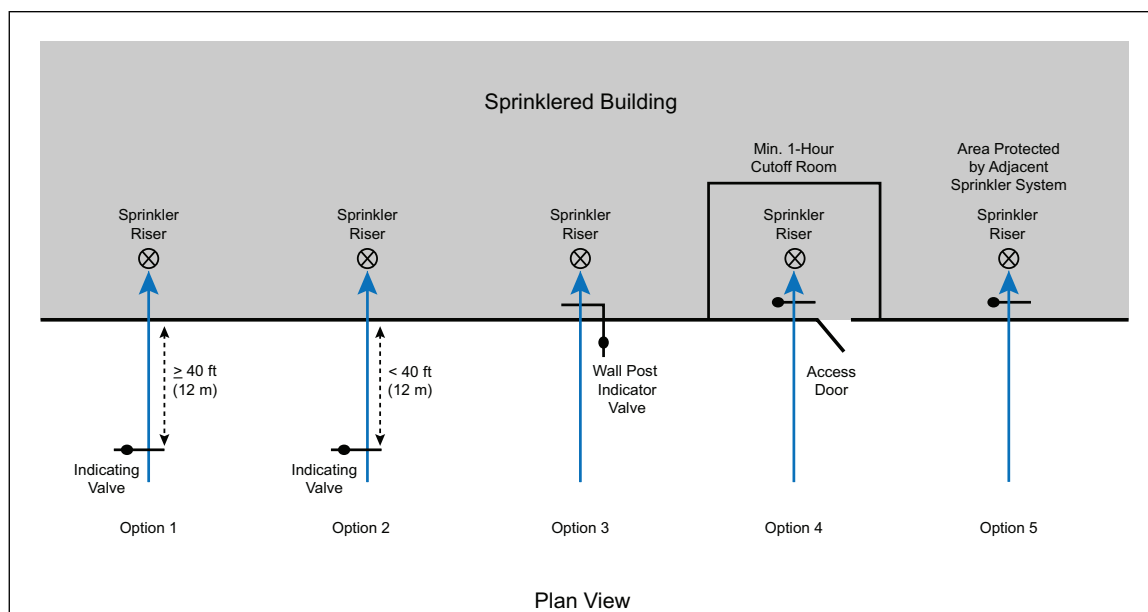

Fig. 2.3.1.2. Examples of arrangements for main sprinkler system control valves

2.3.1.3 If the occupancy hazard requires damage-limiting construction, ensure all outside control valves are located behind a pressure-resistant exterior wall, and all internal control valves are located within an enclosure equipped with pressure-resistant walls.

2.3.1.4 Provide a means of identifying the area of the facility affected by each control valve.

## 2.3.2 Check Valves

2.3.2.1 Install at least one check valve for each sprinkler system. The installation of an alarm check valve, dry-pipe valve, preaction valve, deluge valve, or backflow preventer will meet the intent of this recommendation.

2.3.2.2 FM Approved check valves can be installed in either the vertical or horizontal position as specified in their *Approval Guide* listing.

2.3.2.3 Unless indicated otherwise in the relevant occupancy-specific data sheet, check valves can be installed on a riser equipped with a dry-pipe or preaction sprinkler system valve.

2.3.2.4 Do not install a check valve on a dry-pipe or preaction sprinkler system downstream of a sprinkler system riser (i.e., on a feed main, cross main, etc.) unless specifically indicated otherwise in the relevant occupancy-specific data sheet.

2.3.2.5 See Data Sheet 3-10, *Private Fire Service Mains and Connections*, when backflow prevention devices are required by the authority having jurisdiction.

## 2.3.3 Waterflow Alarms

2.3.3.1 Install at least one alarm device that activates upon waterflow within the sprinkler system.

2.3.3.2 Arrange the waterflow alarm device to initiate an alarm signal no more than 60 seconds after the activation of a sprinkler (i.e., opening of the most remote inspector's test connection installed downstream of the waterflow alarm device).

2.3.3.3 Arrange the waterflow alarm device, at a minimum, to provide local notification for any sprinkler system protecting an area of 2,000 ft<sup>2</sup> (185 m<sup>2</sup>) or larger.

2.3.3.4 When installing a vane-type waterflow alarm, the minimum nominal sprinkler pipe diameter it can be installed on is 2 in. (50 mm).

2.3.3.5 See Data Sheet 9-1, *Supervision of Property*, and Data Sheet 5-40, *Fire Alarm Systems*, for any supplemental recommendations regarding the waterflow alarm device and its monitoring.

## 2.3.4 Inspector's and By-Pass Test Connections

### 2.3.4.1 Inspector's Test Connections

2.3.4.1.1 Install an inspector's test connection downstream of each sprinkler system that is equipped with a waterflow alarm device.

2.3.4.1.2 The installation of an inspector's test connection is not required for an antifreeze solution or deluge sprinkler system.

2.3.4.1.3 Locate the inspector's test connection at the hydraulically most remote part of the sprinkler system for the following sprinkler system types:

- A. Dry-pipe system that has been designed using a specific water delivery time
- B. A non-interlock preaction sprinkler system
- C. A single-interlock preaction sprinkler system not arranged for a wet sprinkler system design
- D. A double-interlock preaction sprinkler system
- E. A refrigerated-area sprinkler system
- F. A vacuum sprinkler system

2.3.4.1.4 The inspector's test connection for a sprinkler system not addressed in Section 2.3.4.1.3 can be located anywhere downstream of the waterflow alarm device.

2.3.4.1.5 For sprinkler systems listed in Section 2.3.4.1.3 where the design is based on the operation of 2 sprinklers (e.g., 2 on the most remote branch line) or 4 sprinklers (2 sprinklers on the 2 most remote branch lines), see Figure 2.3.4.1.5(a) (2 sprinklers) or Figure 2.3.4.1.5(b) (4 sprinklers) for an example of how to arrange the inspector's test connection.

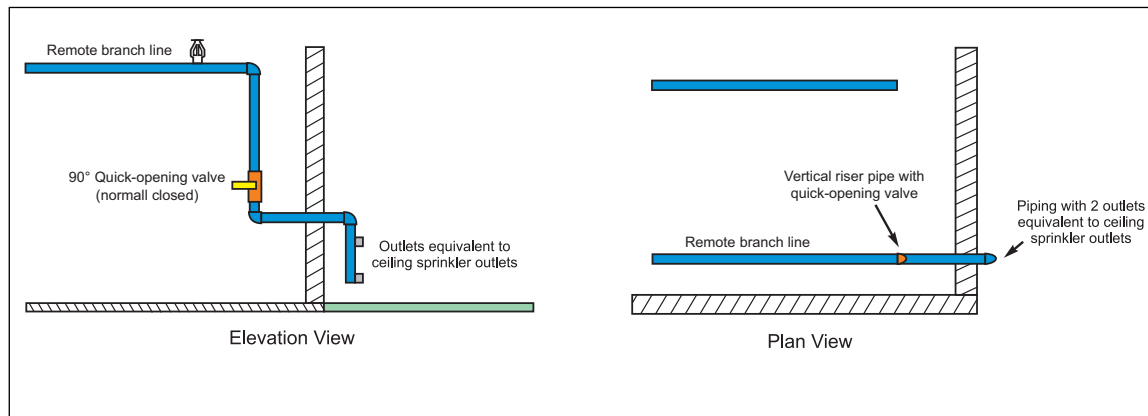

Fig. 2.3.4.1.5(a). Example arrangement of an inspector's test connection for a dry sprinkler system design using 2 sprinklers on the most remote branch line

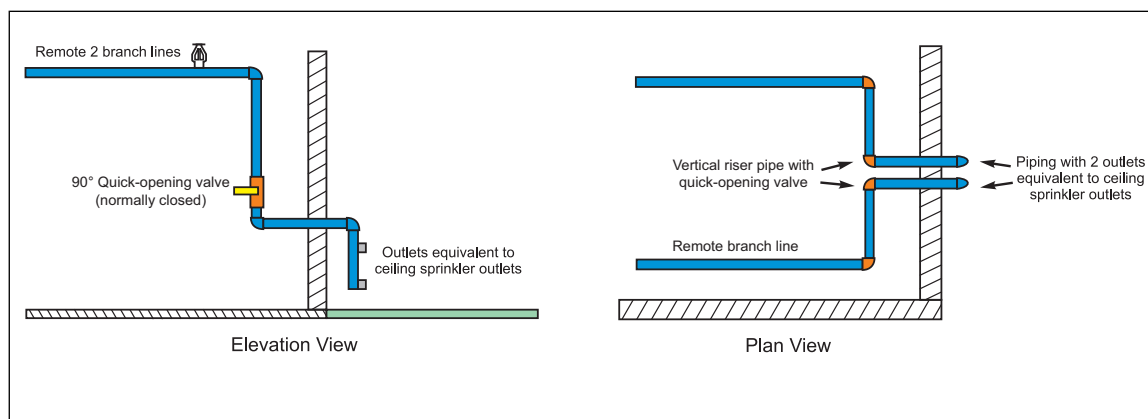

Fig. 2.3.4.1.5(b). Example arrangement of an inspector's test connection for a dry sprinkler system design using 2 sprinklers on the most remote 2 branch lines (4 sprinklers total)

2.3.4.1.6 Connect the inspector's test connection to the sprinkler system using piping that is of nominal minimum 1 in. (25 mm) diameter, but no larger than the smallest system branch line pipe.

2.3.4.1.7 Equip the inspector's test connection with an orifice outlet equal to the smallest orifice of any sprinkler installed on the sprinkler system to which the inspector's test connection is attached.

2.3.4.1.8 Arrange each inspector's test connection so it is readily accessible for testing purposes and will discharge to a location that can handle the maximum anticipated water discharge. Do not arrange the drain to discharge to an indoor area, such as a trench or a slop sink.

2.3.4.1.9 Provide each inspector's test connection with an identification tag that indicates the function of the valve and the system being tested.

### 2.3.4.2 By-Pass Test Connections

2.3.4.2.1 For sprinkler systems addressed in Section 2.3.4.1.3, in addition to installing an inspector's test connection at the hydraulically most remote part of the sprinkler system, install a by-pass test connection at the sprinkler system riser that will allow testing of the system waterflow alarm device independent of the inspector's test connection.

2.3.4.2.2 For an antifreeze solution sprinkler system equipped with a waterflow alarm device, install a by-pass test connection at the sprinkler system riser that will allow testing of the system waterflow alarm device.

2.3.4.2.3 Provide each by-pass test connection with an identification tag that indicates the function of the valve.

### 2.3.5 Pressure Gauges

2.3.5.1 Install pressure gauges that are rated for at least twice the expected static pressure at the point of their installation.

2.3.5.2 At a minimum, install pressure gauges at all of the following locations, as applicable:

- A. On the upstream and downstream sides of any alarm check valve, dry-pipe valve, or preaction type valve
- B. On the upstream and downstream sides of any check valve that is installed on a sprinkler riser in the absence of an alarm check valve, dry-pipe valve, or preaction type valve
- C. On the upstream side of any sprinkler system's automatic system valve that feeds open sprinklers
- D. On the air supply that feeds dry-pipe and preaction type sprinkler systems
- E. On the air receiver and air pump supply if they have been provided on a dry-pipe sprinkler system
- F. At any accelerators on dry-pipe or preaction type sprinkler systems arranged to indicate the air pressure at the accelerator

2.3.5.3 Provide a pressure gauge connection near the most remote sprinkler located on either a deluge or exposure-protection type sprinkler system.

2.3.5.4 Install all sprinkler system pressure gauges so they are readily accessible for visual inspection and for any testing and maintenance requirements.

### 2.3.6 Fire Service Connections

2.3.6.1 Install a fire service connection for each sprinkler system and locate it along an external wall (or equivalent) near the sprinkler system it is intended to supply.

2.3.6.2 Where permitted by the authority having jurisdiction, a single fire service connection may be connected to the underground yard main downstream of any fire pumps and arranged to supply all the sprinkler systems fed from the yard mains. See Data Sheet 3-10, *Private Fire Service Mains and Connections*, for the arrangement of fire service connections installed on yard mains.

2.3.6.3 For individual wet-pipe, preaction type, or deluge sprinkler systems, attach the fire service connection on the downstream side of the sprinkler system valve. See Figure 2.3.6 for an example of this arrangement.

2.3.6.4 For individual dry-pipe sprinkler systems, install a check valve on the sprinkler system riser upstream of the dry-pipe and attach the fire service connection to the riser between the sprinkler system valve and the check valve. See Figure 2.3.6 for an example of this arrangement.

2.3.6.5 For multiple wet-pipe and/or dry-pipe sprinkler systems fed from a manifolded riser, the fire service connection can be attached to the manifold when the manifold is equipped with a check valve located upstream of the fire service connection. See Figure 2.3.6 for an example of this arrangement.

2.3.6.6 Install a minimum 4 in. (100 mm) fire service connection when it will be feeding an 8 in. (200 mm) or smaller sprinkler system riser. Install a minimum 6 in. (150 mm) fire service connection for sprinkler system risers larger than 8 in. (200 mm).

2.3.6.7 Ensure the fire service connection is equipped with fittings and internal connections that are compatible with those of the local fire service.

2.3.6.8 Provide an identification placard at all fire service connections that identifies the sprinkler system the fire service connection supplies.

2.3.6.9 A fire service connection may be omitted from a sprinkler system at the discretion of the authority having jurisdiction.

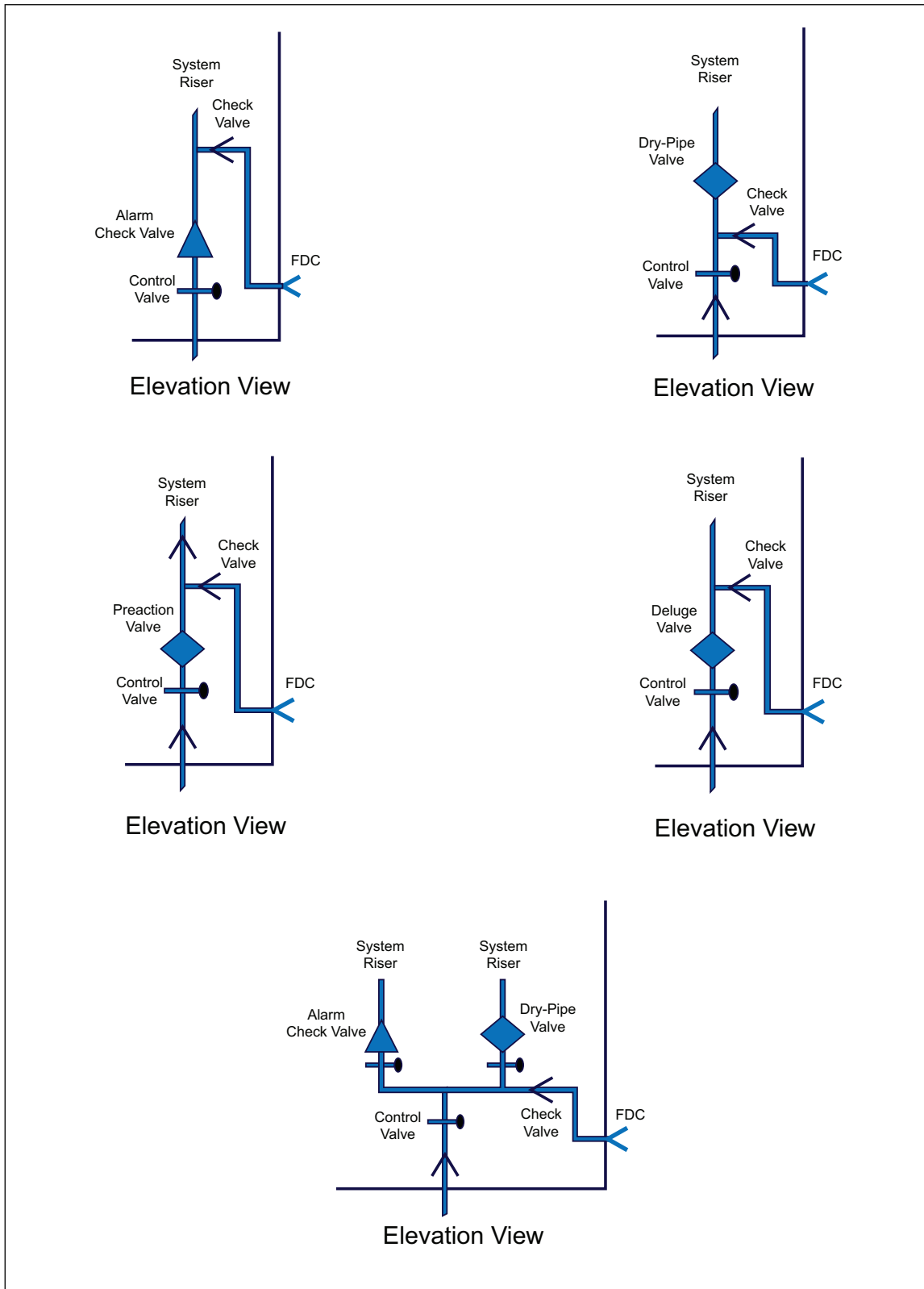

Fig. 2.3.6. Examples of fire department connection arrangements

## 2.3.7 Drain Valves

- 2.3.7.1 Install a minimum 2 in. (50 mm) drain valve at the sprinkler riser for each sprinkler system.
- 2.3.7.2 Arrange each drain valve so it is readily accessible for operation, testing, and maintenance purposes.
- 2.3.7.3 Arrange each drain valve to discharge to an outdoor location that can handle the maximum anticipated water discharge. Do not arrange the drain to discharge to an indoor area, such as a trench or a slop sink.
- 2.3.7.4 Provide each drain valve with an identification tag that indicates the function of the valve.

## 2.3.8 Pressure Relief Valves

- 2.3.8.1 Where the ambient temperature at the sprinkler piping can exceed 120°F (50°C), provide each gridded wet-pipe sprinkler system with a pressure relief valve not less than 1/4 in. (6 mm) in size, or an equivalent pressure relief device, set to operate at the lowest maximum rated working pressure of any of the sprinkler system components.
- 2.3.8.2 Arrange the pressure relief valve to discharge to a safe location (typically into the main drain line).
- 2.3.8.3 Where internally galvanized sprinkler pipe will be installed within a wet-pipe sprinkler system, install pressure relief valves at the high points of the sprinkler system and arrange the valves to discharge directly to the outdoors.

## 2.3.9 Pressure Reducing Valves

- 2.3.9.1 Design sprinkler systems to avoid the need for pressure reducing valves whenever possible.
- 2.3.9.2 When the installation of pressure reducing valves is unavoidable required by the authority having jurisdiction, use FM Approved pressure reducing valves and install them in accordance with Data Sheet 3-11, *Flow and Pressure Regulating Devices for Fire Protection Service*.

## 2.3.10 Orifice Restriction Plates (i.e., Orifice Plates)

- 2.3.10.1 Do not install orifice restriction plates within a sprinkler system.

## 2.3.11 Automatic Breach Containment Valves

Do not install automatic breach containment valves in automatic sprinkler systems. If automatic breach containment valves are required by the local authorities having jurisdiction, see FM Property Loss Prevention Data Sheet 3-11, *Flow and Pressure Regulating Devices*.

## 2.4 Sprinkler System Piping

### 2.4.1 Sprinkler System Pipe

#### 2.4.1.1 Steel Sprinkler Pipe

##### 2.4.1.1.1 Minimum Steel Sprinkler Pipe Diameter Sizes

- 2.4.1.1.1.1 The minimum pipe size for sprinkler system piping (i.e., piping whose purpose is to transport water to a sprinkler) is 1 in. (25 mm).
- 2.4.1.1.1.2 Regardless of the sprinkler pipe size chosen, ensure it is hydraulically proven to meet the minimum design requirements given in the relevant occupancy-specific data sheet.

##### 2.4.1.1.2 Type of Steel Pipe for Sprinkler Systems

2.4.1.1.2.1 In occupancies considered sensitive to water damage (examples might include data centers, museum areas, semi-conductor fabs, etc.), install steel pipe having the minimum wall thickness indicated in Table 2.4.1.1.2.1(a) for nominal pipe sizes measured in inches, or Table 2.4.1.1.2.1(b) for nominal pipe sizes measured in millimeters.

Table 2.4.1.1.2.1(a). Minimum Wall Thickness for Steel Pipe Installed Over Water-Sensitive Occupancies; Nominal Pipe Sizes Measured in Inches

Nominal Pipe Size, in.	Minimum Wall Thickness, in.
1	0.126
1-1/4	0.126
1-1/2	0.126
2	0.142
2-1/2	0.188
3	0.188
3-1/2	0.188
4	0.188
5	0.197
6	0.219
8	0.277
10	0.307
12	0.330

Table 2.4.1.1.2.1(b). Minimum Wall Thickness for Steel Pipe Installed Over Water-Sensitive Occupancies; Nominal Pipe Sizes Measured in Millimeters

Nominal Pipe Size, mm	Minimum Wall Thickness, mm
25	3.2
32	3.2
40	3.2
50	3.6
65	3.6
80	4.0
100	4.5
125	5.0
150	5.0
200	6.3
250	6.3
300	7.1

2.4.1.1.2.2 In wet-pipe or deluge sprinkler systems install:

- A. Black steel, or
- B. Steel sprinkler pipe that is resistant to internal oxidation.

2.4.1.1.2.3 In sprinkler systems other than wet-pipe or deluge, install:

- A. Steel sprinkler pipe that is resistant to internal oxidation, or
- B. Black steel where the gaseous medium for the sprinkler system is in accordance with Section 2.2.1.10 (does not apply to vacuum sprinkler systems).

2.4.1.1.2.4 Do not install steel sprinkler pipe that has been internally galvanized in the following:

- A. Wet-pipe sprinkler systems, or
- B. Areas where the ambient temperature could exceed 130°F (54°C) unless the pipe is specifically FM Approved for use in such conditions.

### 2.4.1.1.3 Pitch of Sprinkler Pipe in Dry-Pipe, Preaction, Refrigerated-Area, and Vacuum Sprinkler Systems

2.4.1.1.3.1 Arrange the sprinkler pipe of dry-pipe and preaction-type sprinkler systems to drain back to the system's main 2 in. (50 mm) riser drain as follows:

- A. Pitch sprinkler branch lines a minimum of 1/2 in. per 10 ft (4 mm/m), and
- B. Pitch all other sprinkler piping a minimum of 1/4 in. per 10 ft (2 mm/m).

2.4.1.1.3.2 For any part of a sprinkler system that cannot drain back to the system's main 2 in. (50 mm) drain, provide auxiliary drains (or equivalent) that will allow for the release of trapped water in the sprinkler system to drain to a safe area.

### 2.4.1.1.4 Bending Steel Pipe for Sprinkler Systems

2.4.1.1.4.1 Bending steel sprinkler pipe of any size is acceptable when:

- A. The minimum wall thickness of the steel sprinkler pipe is 0.100 in. (2.6 mm), and
- B. The minimum radius of a bend is 12 pipe diameters, and
- C. The pipe remains round.

2.4.1.1.4.2 Bending of steel sprinkler pipe where the minimum radius of a bend is less than 12 pipe diameters is acceptable when:

- A. The pipe remains round, and
- B. The minimum wall thickness of the steel sprinkler pipe meets the minimum values indicated in Table 2.4.1.1.4.2.

Table 2.4.1.1.4.2. Recommended Minimum Wall Thickness of Steel Sprinkler Pipe Where the Minimum Radius Bend is Less Than 12-Pipe Diameters

Nominal Pipe Diameter, in. (mm)	Minimum Steel Sprinkler Pipe Wall Thickness, in. (mm)	Allowable Minimum Radius Bend, Pipe Diameters
1 (25)	0.125 (3.2)	6
1-1/4 (32)	0.140 (3.6)	6
1-1/2 (40)	0.140 (3.6)	6
2 (50)	0.155 (4.0)	6
2-1/2 (65)	0.195 (5.0)	5
3 (80)	0.220 (5.6)	5
3-1/2 (90)	0.220 (5.6)	5
4 (100)	0.235 (6.0)	5
5 (125)	0.250 (6.3)	5
6 (150)	0.280 (7.1)	5
8 (200)	0.315 (8.0)	5
10 (250)	0.345 (8.8)	5
12 (300)	0.405 (10.3)	5

### 2.4.1.1.5 Protection of Sprinkler System Pipe

2.4.1.1.5.1 See Data Sheet 7-14, *Fire Protection for Chemical Plants*, for installation guidelines of sprinkler system pipe in areas subject to potential explosion hazards.

2.4.1.1.5.2 To help reduce the potential for accelerated internal pipe corrosion of longitudinally welded black steel sprinkler system pipe, where possible, install the pipe with the weld line rotated at least 45° in relationship to the floor, (for reference, the weld line points at the floor at 0°). **Note that FM Approved stretched-reduced mill manufactured steel sprinkler pipe can be installed without consideration of the pipe's weld line alignment relative to the floor.**

2.4.1.1.5.3 Ensure the ends of all sprinkler system pipe are smooth and free of any burrs or fins.

2.4.1.1.5.4 Do not hang anything, including conduit, cable trays, air piping, speakers, or signs, from sprinkler system pipe.

### 2.4.1.2 Flexible Steel Sprinkler Pipe

2.4.1.2.1 When using flexible metallic pipe, ensure it is FM Approved and compatible with the hazard it is intended to protect. Follow the manufacturer's guidelines for installing the pipe and refer to their guidelines for analysis of the anticipated friction loss through the length of pipe installed.

### 2.4.1.3 Non-Metallic Sprinkler Pipe

2.4.1.3.1 See Data Sheet 2-8, *Earthquake Protection for Water-Based Fire Protection Systems*, for restrictions involving non-metallic sprinkler pipe in areas subject to earthquakes.

2.4.1.3.2 The installation of nonmetallic sprinkler pipe is acceptable only in nonstorage-type occupancies.

2.4.1.3.3 Shield all nonmetallic sprinkler pipe with a minimum 15 minute-rated, non-removable fixed-in-place barrier.

2.4.1.3.4 Nonmetallic sprinkler pipe can be exposed (i.e., not shielded from the occupancy hazard) when:

- A. The nonmetallic sprinkler pipe is FM Approved specifically as an exposed pipe, and
- B. The occupancy hazard is HC-1 per Data Sheet 3-26, *Fire Protection for Nonstorage Occupancies*, and
- C. The maximum ceiling height of the protected area is 30 ft (9.1 m), and
- D. The sprinkler system is wet-pipe, and
- E. The ceiling sprinklers are quick-response, and
- F. The vertical pipe sections of the sprinkler system are metallic. However, the vertical pipe sections of the sprinkler system can be exposed nonmetallic pipe when they are protected by quick-response, upright sprinklers located no more than 1 ft (0.3 m) horizontally from the vertical pipe sections.

2.4.1.3.5 The use of nonmetallic sprinkler pipe in nominal pipe sizes of 3 in. (90 mm) or larger is acceptable when used solely as piping for the sprinkler riser.

### 2.4.2 Sprinkler System Pipe Connections and Assemblies

#### 2.4.2.1 General Recommendations for Sprinkler System Pipe Connections

2.4.2.1.1 Use FM Approved one-piece reducing fittings when connecting two sprinkler system pipes of different size.

2.4.2.1.2 Do not allow sprinkler system pipe connections, such as mechanical tees, to extend into the flow path of the sprinkler system piping.

#### 2.4.2.2 Threaded, Grooved and Welded Sprinkler System Pipe Connections

##### 2.4.2.2.1 General

See either Table 2.4.2.2.1(1) or Table 2.4.2.2.1(2) for the recommended minimum steel pipe wall thickness specific to threaded, roll-grooved, cut-grooved, or welded sprinkler piping.

Table 2.4.2.2.1(1). Recommended Minimum Steel Pipe Wall Thickness for Threaded, Roll-Grooved, Cut-Grooved, and Welded Sprinkler Piping in Inches

Nominal Pipe Size (NPS), in.	Roll-Grooved or Welded Pipe, in.	Threaded or Cut-Groove Pipe, in.
1	0.102*	0.133
1-1/4	0.102*	0.140
1-1/2	0.102*	0.145
2	0.102*	0.154
2-1/2	0.102	0.203
3	0.114	0.216
3-1/2	0.114	0.226
4	0.126	0.237
5	0.142	0.258
6	0.158	0.280
8	0.177	0.277
10	0.197	0.307
12	0.220	0.330

\* The minimum wall thickness for roll-grooved steel pipe can be 0.065 in. when used with couplings or fittings indicated in the Approval Guide specifically for this minimum wall thickness

Table 2.4.2.2.1(2). Recommended Minimum Steel Pipe Wall Thickness for Threaded, Roll-Grooved, Cut-Grooved, and Welded Sprinkler Piping in Millimeters

Nominal DN Pipe Diameter, mm	Welded or Roll-Grooved Pipe, mm	Threaded or Cut-Groove Pipe, mm
25	2.6*	3.2
32	2.6*	3.2
40	2.6*	3.2
50	2.6*	3.6
65	2.6	3.6
80	2.9	4.0
100	3.2	4.5
125	3.6	5.0
150	4.0	5.0
200	4.5	6.3
250	5.0	6.3
300	5.6	7.1

\* The minimum wall thickness for roll-grooved steel pipe can be 1.7 mm when used with couplings or fittings indicated in the Approval Guide specifically for this minimum wall thickness

### 2.4.2.2.2 Threaded Steel Sprinkler System Pipe Connections

2.4.2.2.2.1 Ensure the threads of the sprinkler system piping are cut in accordance with local codes and are compatible with the threads of the sprinkler system pipe connection.

2.4.2.2.2.2 Apply joint compound, tape, or similar thread-sealing material to the male threads of all threaded connections in accordance with the manufacturer’s instructions. Ensure the application of the sealing material does not interfere with the full engagement of the male and female threads.

### 2.4.2.2.3 Grooved Steel Sprinkler System Pipe Connections

2.4.2.2.3.1 Ensure the groove dimensions of the sprinkler pipe meet the requirements of the grooved coupling manufacturer.

2.4.2.2.3.2 Unless indicated otherwise by the sprinkler pipe’s listing in the *Approval Guide*, roll groove all sprinkler pipe prior to its being galvanized or painted.

### 2.4.2.2.4 Welded Steel Sprinkler System Pipe Connections

2.4.2.2.4.1 Use FM Approved welded pipe connections and welded formations.

2.4.2.2.4.2 Ensure welding methods and qualifications for joining sprinkler system piping comply with the minimum requirements of the latest version of ANSI/AWS B2.1, Specification for Welding Procedure and Performance Qualification, EN ISO 9606-1, *Qualification Testing of Welders – Fusion Welding – Part 1: Steels*, or an equivalent method.

2.4.2.2.4.3 A fitting is not required where pipe ends are butt-welded in accordance with acceptable welding methods.

2.4.2.2.4.4 Ensure all hot work operations associated with the welding of sprinkler pipe on site are carried out in accordance with the recommendations in Data Sheet 10-3, *Hot Work Management*.

2.4.2.2.4.5 Ensure the welding environment does not adversely affect the quality of the welding.

2.4.2.2.4.6 Ensure the holes cut into sprinkler piping for fitting outlets are the same size diameter as the fitting and are free of burrs or fins.

2.4.2.2.4.7 Document that all coupons or discs cut from sprinkler piping have been removed from within the sprinkler system piping prior to placing the system in service.

### 2.4.2.3 Plain-End Steel Sprinkler System Pipe Connections

2.4.2.3.1 Use FM Approved sprinkler pipe that is specifically listed with FM Approved plain-end or similar pipe connections when the wall thickness of the sprinkler pipe is less than 0.133 in. (3.38 mm).

2.4.2.3.2 See the manufacturer’s installation guidelines to determine how to apply the correct torque to the plain-end connection’s fasteners.

### 2.4.3 Sprinkler System Pipe Hanging and Bracing

#### 2.4.3.1 Sprinkler System Pipe Hangers and their Components

2.4.3.1.1 Install pipe hangers, their pipe hanger assemblies (struts, rods, brackets, straps, welded connections, fasteners, etc.), and the components used to connect it to the building structure (concrete inserts, post-installed concrete anchors, welds, clamps, bolts, screws, etc.) that are FM Approved.

2.4.3.1.2 Ensure all auxiliary components, such as rods and angle steel, that supplement the attachment of pipe hangers and fasteners listed in the *Approval Guide* are of ferrous material and are compatible with the environment in which they will be installed.

2.4.3.1.3 When using steel rods to connect a pipe hanger to a fastener, use the following minimum rod diameter sizes and thread engagements depending on the size of the supported sprinkler pipe as shown in Table 2.4.3.1.3.

Table 2.4.3.1.3. Recommended Minimum Steel Rod Sizes and Thread Engagement Lengths

Nominal Sprinkler Pipe Diameter, in. (mm)	Minimum Rod Diameter, in. (mm)	Minimum Rod Thread Engagement, in. (mm)
1 through 4 (25 through 100)	3/8 (10)	0.32 (8.0)
5, 6 and 8 (125, 150 and 200)	1/2 (12)	0.43 (10.4)
10 and 12 (250 and 300)	5/8 (16)	0.54 (14.1)

#### 2.4.3.2 Attachment of Sprinkler System Pipe Hangers

##### 2.4.3.2.1 General Recommendations for the Attachment of Sprinkler System Pipe Hangers

2.4.3.2.1.1 Ensure the pipe hanger fastener or anchor is compatible with the material to which it is attached (including wood).

2.4.3.2.1.2 Ensure supporting structural members (e.g., purlins, joists, beams, or slabs) are adequate to resist the additional gravity point loads from all hangers attached to them plus a single additional 250 lb (113 kg) gravity point load applied at the most critical hanger location for that member. Ensure the gravity load on each hanger equals the weight of the water-filled sprinkler system piping tributary to it. Assume these are dead

loads and multiply them by the proper load factors for the design method used. For Allowable Stress Design (ASD), the load factor for dead loads is typically 1.0. For Strength Design (Load and Resistance Factor Design [LRFD]) the load factor for dead loads is typically 1.4 when considered alone, or 1.2 for load combinations, including live loads.

2.4.3.2.1.3 When attaching sprinkler system pipe support assemblies to a building structure, ensure the building structure can support the added minimum load due to the weight of the water-filled sprinkler system.

2.4.3.2.1.4 When attaching sprinkler system pipe support assemblies to a non-building structure, obtain calculations that ensure the design of the non-building structure accounts for the load imposed by the sprinkler system piping.

#### **2.4.3.2.2 Attachment of Sprinkler System Pipe Hangers to Steel Decking**

2.4.3.2.2.1 Do not attach pipe hangers directly to roof decking.

2.4.3.2.2.2 Pipe hangers supporting branch line pipe only in sizes up to and including 3 in. (75 mm) can be attached to steel decking if all of the following conditions are met:

- A. The distance between building structural supports is more than the maximum allowable distance between piping supports for branch lines; and
- B. The pipe hanger fasteners are listed in the *Approval Guide* as compatible for steel decking; and
- C. The pipe hanger fasteners are installed in accordance with the manufacturer's installation guidelines; and
- D. The structural design of the steel decking can account for the dead, live, and collateral loads of any items attached to it, as well as the required minimum load of the sprinkler system piping.

#### **2.4.3.2.3 Attachment of Sprinkler System Pipe Hangers to Steel Purlins**

2.4.3.2.3.1 Attach pipe hanger fasteners to C-shaped or Z-shaped steel secondary roof members (purlins) in accordance with the building manufacturer's specifications. In addition, ensure the building structure can adequately support the added minimum load of the sprinkler system piping (based on the effective section properties of the members).

2.4.3.2.3.2 If the building manufacturer is not known or is no longer available for advice, use the following guidelines:

- A. Z-shaped purlins: Attach pipe hanger fasteners to the midpoint of the vertical web. As an alternative, pipe hanger fastener can be attached to the bottom flange of the Z-shaped purlin at a point as close to the vertical web as possible, but at a distance from the vertical web no further than 1/2 of the flange width. Do not, under any circumstances, use the purlin flange stiffener as the point of attachment, or allow the pipe hanger assembly to contact the flange stiffener.
- B. C-shaped purlins: Attach pipe hanger fasteners to the midpoint of the vertical web. Do not, under any circumstances, use the purlin flange stiffener as the point of attachment, or allow the pipe hanger assembly to contact the flange stiffener.
- C. See Figure 2.4.3.2.3.2 for additional guidance.

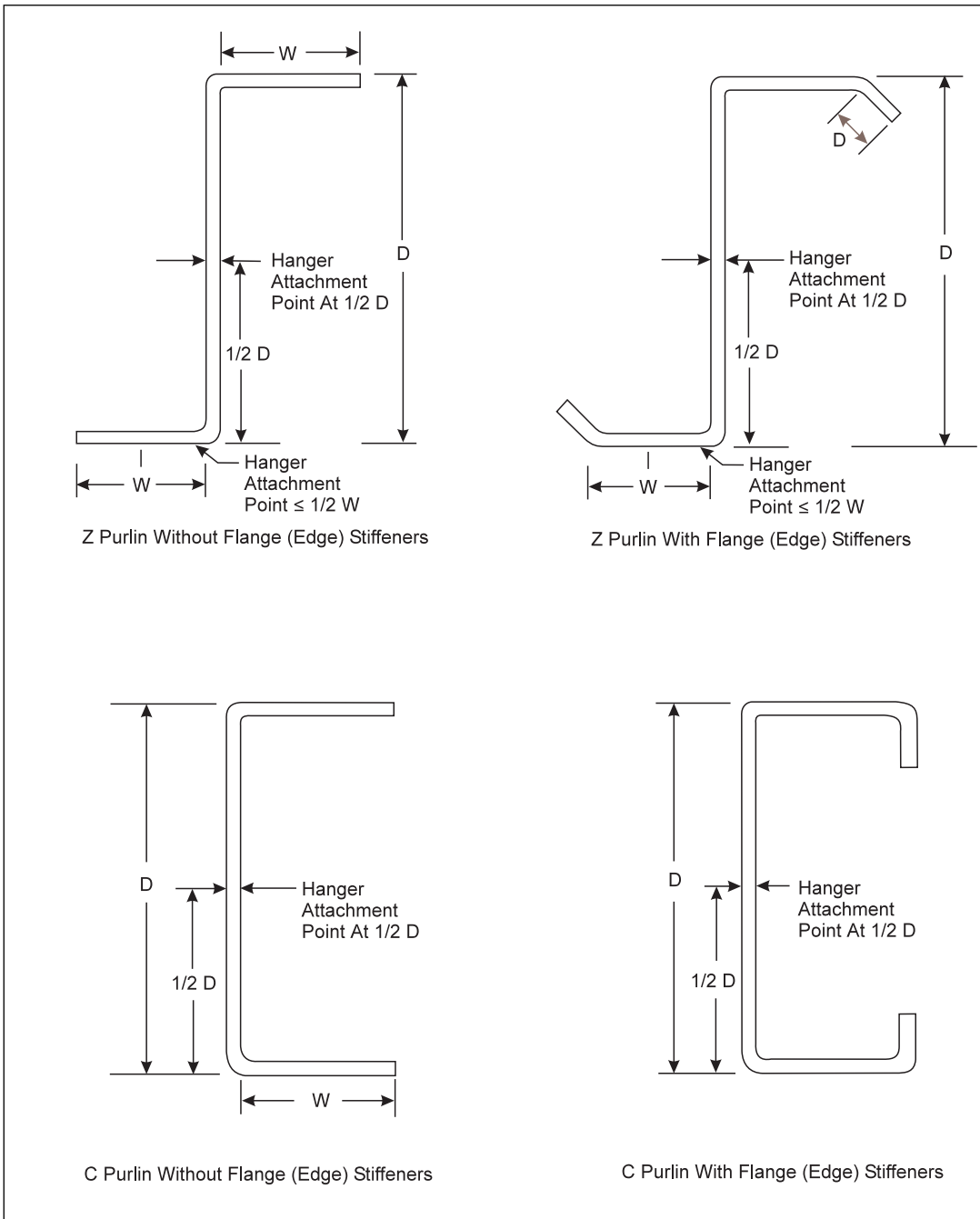

Fig. 2.4.3.2.3.2. Attachment locations for hangers with C-shaped or Z-shaped purlins

**2.4.3.2.4 Attachment of Sprinkler System Pipe Hangers to Concrete**

2.4.3.2.4.1 Attach pipe hangers to structural concrete using inserts, expansion anchors, or fasteners FM Approved for use in concrete and installed in accordance with the manufacturer’s guidelines and the recommendations in this section.

2.4.3.2.4.2 Ensure the piping supports can support the minimum load of the sprinkler system piping per Section 2.4.3.2.1.

2.4.3.2.4.3 For all concrete fasteners, ensure the fastener installation will not damage concrete reinforcement, such as steel reinforcing bars (rebar) for cast-in-place or pre-cast concrete, high-strength steel strand in precast/prestressed concrete, or high-strength steel tendon (bonded or unbonded) in post-tension concrete.

2.4.3.2.4.4 Do not install concrete fasteners into hollow concrete block (masonry) construction.

2.4.3.2.4.5 If a powder-actuated fastener system (PAFS) is used, ensure the powder-actuated tool and the explosive-driven fastener are FM Approved and compatible with the material into which the fastener is being driven.

2.4.3.2.4.6 In FM earthquake zones less than or equal to 500 years, do not use powder-actuated fastener systems for sprinkler pipe supports or bracing. See Data Sheet 2-8, *Earthquake Protection for Water-Based Fire Protection Systems*, for additional guidance.

2.4.3.2.4.7 For structural concrete members, install FM Approved undercut-type fasteners in either a vertical or horizontal orientation. Install all other concrete fasteners in a horizontal position only unless they meet the criteria in Section 2.4.3.2.5.

### 2.4.3.2.5 Field Testing of Concrete Fasteners

2.4.3.2.5.1 To ensure fasteners can meet the minimum loads recommended in Section 2.4.3.2.4, conduct a load-supporting field test on at least 3 representative pipe hangers per ceiling when:

- A. Post-installed concrete fasteners (other than under-cut fasteners) are installed in the vertical orientation and are used to support piping larger than 3 in. (80 mm), or
- B. Explosive-driven-fasteners are used, or
- C. Any type of fastener, regardless of its orientation, is installed into light-weight structural or similar type concrete.

2.4.3.2.5.2 Base the load for the field tests on two (2) times the tributary weight of the water-filled sprinkler system piping.

### 2.4.3.2.6 Attachment of Sprinkler System Pipe Hangers to Composite Wood Truss/Joist

For hanging sprinkler pipe from composite wood truss/joist, consult the truss manufacturer for their recommended installation point.

### 2.4.3.3 Location and Spacing of Sprinkler System Pipe Hangers

#### 2.4.3.3.1 Support for Horizontal Steel Sprinkler Piping

2.4.3.3.1.1 Arrange sprinkler system pipe hangers so the maximum horizontal distance between them when supporting steel sprinkler pipe is either (1) in accordance with Table 2.4.3.3.1.1 based on the minimum wall thickness of the sprinkler pipe being installed, or (2) when applicable, in accordance with the pipe's specific listing provided in the *Approval Guide*.

Table 2.4.3.3.1.1. Recommended Maximum Horizontal Distance Between Pipe Hangers Supporting Steel Sprinkler Pipe

Sprinkler Pipe Material	Maximum Horizontal Distance Between Sprinkler Pipe Hangers, ft (m)						
	Nominal Pipe Diameter, in. (mm)						
	1 (25)	1-1/4 (32)	1-1/2 (40)	2 (50)	2-1/2 (65)	3 (80)	Greater than 3 (80)
Steel Pipe with wall thicknesses less than those indicated in Table 2.4.3.3.1.1(1)	12 (3.7)	12 (3.7)	12 (3.7)	12 (3.7)	12 (3.7)	12 (3.7)	Not Applicable; Use pipe with minimum wall thickness per Table 2.4.3.3.1.1(1)
Steel Pipe with wall thicknesses equal to or greater than those indicated in Table 2.4.3.3.1.1(1)	12 (3.7)	12 (3.7)	15 (4.6)	15 (4.6)	15 (4.6)	15 (4.6)	15 (4.6)

Table 2.4.3.1.1(1). Minimum Wall Thickness of Sprinkler Piping for Use with Table 2.4.3.3.1.1

Nominal Pipe Size, in. (mm)	Minimum Wall Thickness, in. (mm)
1 (25)	0.105 (2.7)
1-1/4 (32)	0.105 (2.7)
1-1/2 (40)	0.105 (2.7)
2 (50)	0.105 (2.7)
2-1/2 (65)	0.115 (2.9)
3 (80)	0.115 (2.9)
3-1/2 (90)	0.115 (2.9)
4 (100)	0.115 (2.9)
5 (125)	0.130 (3.3)
6 (150)	0.130 (3.3)
8 (200)	0.180 (4.6)
10 (250)	0.180 (4.6)
12 (300)	0.180 (4.6)

2.4.3.3.1.2 Arrange sprinkler system pipe hangers so that any section of sprinkler pipe over 6 ft (1.8 m) in length is supported by at least one pipe hanger.

2.4.3.3.1.3 The maximum distance between pipe hangers supporting cross mains, near mains, and far mains may be increased by 5 ft (1.5 m) over the values indicated in Table 2.4.3.3.1.1 when all branch lines located between the main's hangers are equipped with hangers that meet one of the following:

- A. Within 6 ft (1.8 m) of the connection to the main, or
- B. Within one-half the distance indicated in Table 2.4.3.3.1.1.

2.4.3.3.1.4 Install hangers on cross mains, near mains, and far mains within 3 ft (0.9 m) horizontally from the last branch line.

2.4.3.3.1.5 Install hangers on cross mains, near mains, and far mains within 2 ft (0.6 m) horizontally from any connection to a vertical section of pipe.

2.4.3.3.1.6 Install hangers on branch lines within 1 ft (0.3 m) horizontally of the main when the hanger for the main is located more than 6 ft (1.8 m) horizontally from the branch line connection.

2.4.3.3.1.7 Install hangers on branch lines within 1 ft (0.3 m) horizontally of the sprinkler pipe's connection where there is a horizontal change in the direction of flow.

2.4.3.3.1.8 Install hangers on branch lines within 1 to 3 ft (0.3 to 0.9 m) horizontally from the last sprinkler on a branch line having single-path flow.

2.4.3.3.1.9 For sprinkler pipe having a nominal pipe diameter 2-1/2 in. (65 mm) or larger, the maximum horizontal distance between hangers indicated in Table 2.4.3.3.1.1 can be increased to 26 ft (8 m) if two pipe hangers, no more than 3 ft (0.9 m) apart horizontally, are provided on either side of the pipe's coupling. See Figure 2.4.3.3.1.9 for a visual representation of this arrangement.

2.4.3.3.1.10 For sprinkler pipe having a nominal pipe diameter 5 in. (125 mm) and larger, the maximum horizontal distance between hangers indicated in Table 2.4.3.3.1.1 can be increased by up to 5 ft (1.5 m) if there are a minimum of 2 hangers per pipe section.

2.4.3.3.1.11 When upright sprinklers are installed, arrange the sprinkler system pipe hangers as follows:

- A. A minimum horizontal distance of 3 in. (75 mm) from all upright sprinklers protecting a nonstorage occupancy hazard, or
- B. A minimum horizontal distance of 12 in. (300 mm) from all upright sprinklers protecting a storage occupancy hazard.

2.4.3.3.1.12 See the *Approval Guide* for the required location and spacing of pipe hangers for FM Approved non-rigid sprinkler piping (i.e., flexible sprinkler hose).

### 2.4.3.3.2 Support for Vertical Steel Sprinkler Pipe

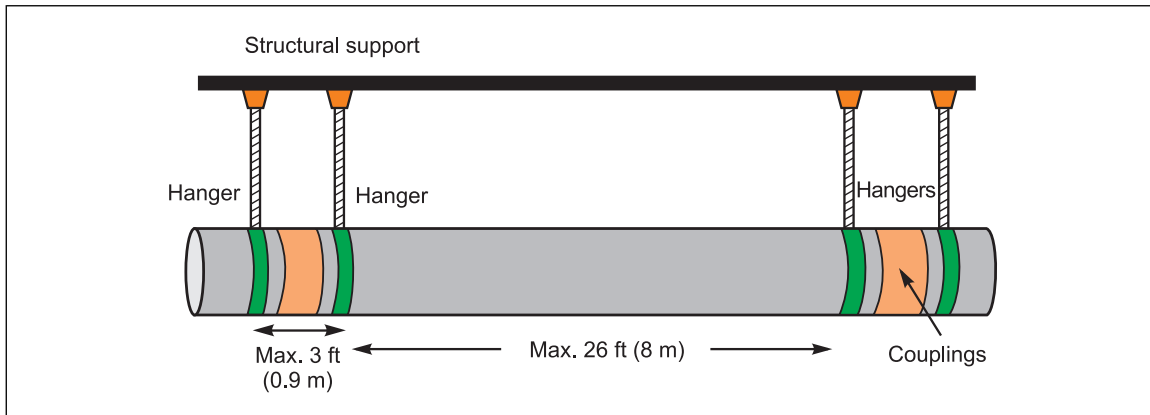

Fig. 2.4.3.3.1.9. Piping arrangement for maximum horizontal distance of 26 ft (8 m) between pipe hangers

2.4.3.3.2.1 Support vertical sprinkler system risers at their base, accounting for both the weight of the vertical column of water and the sprinkler pipe. When such piping changes from a vertical to a horizontal orientation, provide support of the vertical pipe, whether via a hanger or a pipe stand, within 1 ft (0.3 m) horizontally of the point of pipe orientation change.

2.4.3.3.2.2 Support vertical sprinkler piping at least every 12 ft (3.6 m) using a piping support that is specifically manufactured for vertically running pipe. Install the piping support in accordance with the recommendations in this section and the manufacturer's installation guidelines.

2.4.3.3.2.3 Provide additional support for any vertical sprinkler pipe 4 ft (1.2 m) long or more to which an upright sprinkler is directly attached.

2.4.3.3.2.4 Provide additional support for any vertical sprinkler piping 4 ft (1.2 m) long or more to which a pendent sprinkler is directly attached.

2.4.3.3.2.5 The maximum vertical distance in Section 2.4.3.3.2.4 can be increased to 12 ft (3.6 m) when a pendent sprinkler is secured to a supported structure, such as a suspended ceiling or a piece of ductwork.

2.4.3.3.2.6 Provide additional support to restrict the rotation of wall-mounted sidewall sprinklers.

2.4.3.3.2.7 When grooved couplings are used for to connect branch line sprinkler pipe, provide additional support to restrict upward movement for all return bends, armovers, and similar sprinkler pipe arrangements.

2.4.3.3.2.8 When branch line sprinkler pipe is connected by means other than grooved couplings, provide additional support to restrict upward movement for all return bends, armovers, and similar sprinkler pipe arrangements that are more than 2 ft (0.6 m) horizontally in length.

### 2.4.3.3.3 Support for Nonmetallic Sprinkler Pipe

The strength of nonmetallic pipe varies considerably from product to product. Follow the manufacturer's requirements for hanger type as well as horizontal and vertical spacing when installing nonmetallic pipe.

## 2.5 Sprinklers

### 2.5.1 General Recommendations for Sprinklers

#### 2.5.1.1 Recommended Nominal Temperature Rating and Minimum Design Pressures of Sprinklers

##### 2.5.1.1.1 Recommended Nominal Temperature Rating of Sprinklers

See the occupancy-specific data sheet to determine the recommended nominal temperature rating of the sprinklers to be installed. However, if the ambient temperature of the protected area at the sprinklers will exceed 100°F (38°C), see Table 2.5.1.1.1 to determine the recommended nominal temperature for the sprinklers.

*Table 2.5.1.1.1. Nominal Temperature Ratings of Sprinklers Based on the Maximum Ambient Temperature at the Sprinkler*

<i>Maximum Ambient Temperature at Sprinkler Level, F° (C°)</i>	<i>Nominal Temperature Rating of Sprinkler, F° (C°)</i>	<i>Temperature Classification of Sprinkler</i>	<i>Color of Sprinkler Glass Bulb<sup>(Note 1)</sup></i>
100 (40)	135 (55)	Ordinary	Orange
100 (40)	160 (70)	Ordinary	Red
150 (65)	175 (80)	Ordinary	Yellow
150 (65)	212 (100)	Intermediate	Green
225 (110)	280 (140)	High	Blue
300 (150)	350 (175)	Extra High	Mauve
375 (190)	425 (220)	Very Extra High	Black
475 (245)	525 (275)	Ultra High	Black
625 (330)	650 (345)	Ultra High	Black

Note 1. In several countries, the arm frames of the sprinkler are provided with a color coding to represent the temperature classification of the sprinkler. Check the local country code to determine the temperature classification for the sprinkler based on the sprinkler's arm-frame color.

### 2.5.1.1.2 Recommended Minimum Design Pressures of Sprinklers

See the occupancy-specific data sheet to determine the recommended protection design for the ceiling sprinkler system and, if applicable, the in-rack sprinkler system. **When the design for a sprinkler (ceiling or in-rack) is provided in terms of either density or flow, calculate the corresponding design pressure and compare it to the value indicated in Table 2.5.1.1.2 for the specific sprinkler being installed. If the calculated pressure is less than the value indicated in Table 2.5.1.1.2 for the specific sprinkler being installed, use the pressure indicated in Table 2.5.1.1.2 for design purposes.**

Table 2.5.1.1.2. Minimum Design Pressures for Sprinklers

Sprinkler K-Factor	Sprinkler Coverage Type	Sprinkler Orientation	Sprinkler RTI Rating	Sprinkler Application	Sprinkler Spacing, ft (m)	Minimum Design Pressure, psi (bar)	
K5.6 (K80)	Standard	Pendent, Sidewall, or Upright	Quick or Standard	Nonstorage	As permitted	7 (0.5)	
		Dry-Pendent or Dry-Sidewall	Quick or Standard	Nonstorage	As permitted	7 (0.5)	
		Dry-Upright	Quick or Standard	Nonstorage	As permitted	10 (0.7)	
	Extended	Pendent	Quick	Nonstorage	As permitted	7 (0.5)	
		Sidewall	Quick	Nonstorage	16 x 16 (4.9 x 4.9)	22 (1.5)	
					16 x 18 (4.9 x 5.5)	29 (2.0)	
					16 x 20 (4.9 x 6.1)	35 (2.4)	
	K8.0 (115)	Standard	Pendent, or Upright	Quick or Standard	Nonstorage	As permitted	7 (0.5)
			Dry-Pendent	Quick or Standard	Nonstorage	As permitted	7 (0.5)
Dry-Upright			Quick or Standard	Nonstorage	As permitted	10 (0.7)	
Extended		Pendent	Quick	Nonstorage	As permitted	7 (0.5)	
		Sidewall	Quick	Nonstorage	16 x 16 (4.9 x 4.9)	16 (1.1)	
					16 x 18 (4.9 x 5.5)	20 (1.4)	
					16 x 20 (4.9 x 6.1)	25 (1.7)	
					16 x 22 (4.9 x 6.7)	30 (2.1)	
					16 x 24 (4.9 x 7.3)	36 (2.5)	
K11.2 (K160)	Standard-	Pendent or Upright	Quick or Standard	Nonstorage or Storage	As permitted	7 (0.5)	
	Extended	Pendent or Upright	Quick	Nonstorage	As permitted	12 (0.8)	
K14.0 (K200)	Standard-	Pendent	Quick or Standard	Nonstorage	As permitted	7 (0.5)	
		Upright	Quick	Nonstorage	As permitted	7 (0.5)	
		Pendent	Quick	Storage	As permitted	10 (0.7)	
			Standard	Storage	As permitted	7 (0.5)	
		Upright	Quick	Storage	As permitted	7 (0.5)	
	Extended	Pendent or Upright	Quick	Nonstorage	As permitted	18 (1.2)	
		Sidewall	Quick	Nonstorage or Storage	As permitted	7 (0.5)	
K16.8 (240)	Standard	Pendent	Quick	Nonstorage	As permitted	7 (0.5)	
		Upright	Quick or Standard	Nonstorage	As permitted	7 (0.5)	
		Pendent	Quick	Storage	As permitted	10 (0.7)	
		Upright	Quick or Standard	Storage	As permitted	7 (0.5)	
K19.6 (K280)	Standard	Pendent	Standard	Nonstorage	As permitted	7 (0.5)	
				Storage	As permitted	10 (0.7)	

Table 2.5.1.1.2. *Minimum Design Pressures for Sprinklers (continued)*

Sprinkler K-Factor	Sprinkler Coverage Type	Sprinkler Orientation	Sprinkler RTI Rating	Sprinkler Application	Sprinkler Spacing, ft (m)	Minimum Design Pressure, psi (bar)
K22.4 (K320)	Standard	Pendent	Quick	Nonstorage	As permitted	10 (0.7)
				Storage	As permitted	15 (1.0)
K25.2 (K360)	Standard	Pendent	Quick	Nonstorage	As permitted	10 (0.7)
		Pendent or Upright	Standard	Nonstorage	As permitted	7 (0.5)
		Pendent	Quick	Storage	As permitted	15 (1.0)
		Upright	Quick or Standard	Storage	As permitted	10 (0.7)
	Extended	Pendent or Upright	Quick	Nonstorage	As permitted	10 (0.7)
				Storage	As permitted	20 (1.4)
K28.0 (K400)	Standard	Pendent	Quick	Nonstorage	As permitted	15 (1.0)
				Storage	As permitted	20 (1.4)
K33.6 (K480)	Standard	Pendent	Quick	Nonstorage	As permitted	15 (1.0)
				Storage	As permitted	20 (1.4)
		Upright	Standard	Nonstorage	As permitted	10 (0.7)
				Storage	As permitted	20 (1.4)

### 2.5.1.2 Mixing Sprinklers in the Same Area

2.5.1.2.1 Do not mix sprinklers with different coverage types, K-factors, orientations, RTI ratings, and/or temperature ratings within the same area.

2.5.1.2.2 Ceiling-level sprinklers with different K-factor values can be installed in the same area if:

- A. They are used to protect two adjacent occupancy hazards that require different sprinkler designs, and
- B. The sprinkler thread sizes for the two sprinklers are different.

When parts A and B are both satisfied, extend the design of the sprinkler system protecting the higher-hazard occupancy a minimum of one sprinkler in all directions beyond the perimeter of the higher-hazard occupancy area.

2.5.1.2.3 Ceiling-level pendent and upright sprinklers can be installed in the same area if they are used to protect two adjacent occupancy hazards that require different sprinkler designs. Extend the design of the sprinkler system protecting the higher-hazard occupancy a minimum of one sprinkler in all directions beyond the perimeter of the higher-hazard occupancy area.

2.5.1.2.4 An upright sprinkler can be substituted for an obstructed pendent sprinkler if:

- A. The upright sprinkler has the same attributes as the pendent sprinkler (other than orientation), and
- B. The upright sprinkler is an acceptable option to protect the occupancy hazard.

2.5.1.2.5 Ceiling level sprinklers with different RTI ratings can be installed in the same area if:

- A. A minimum 2 ft (0.6 m) deep solid noncombustible draft curtain is installed to separate the area protected by quick-response sprinklers from the area protected by standard-response sprinklers, and
- B. A minimum 7-1/2 ft (2.3 m) wide space, measured away from the draft curtain, clear of combustibles is provided on the side of the draft curtain protected by standard-response sprinklers.

2.5.1.2.6 Ceiling level sprinklers with different RTI ratings can be installed in the same area if:

- A. There is a minimum 2 ft (0.6 m) elevation difference between adjacent ceilings, and
- B. Standard-response sprinklers are installed beneath the higher elevated ceiling, and
- C. A minimum 7-1/2 ft (2.3 m) wide space, measured away from the elevation difference, clear of combustibles is provided on the side protected by standard-response sprinklers.

2.5.1.2.7 Ceiling-level sprinklers with the same K-factor, orientation, RTI rating, and coverage type attributes, but with different nominal temperature ratings can be installed in the same area if isolated ambient temperature conditions (such as near unit heater outlets) require a higher sprinkler temperature rating.

2.5.1.2.8 Sidewall sprinklers can be installed in the same area being protected by pendent and upright sprinklers.

### 2.5.1.3 Draft Curtains

2.5.1.3.1 Do not install draft curtains unless they are recommended for a specific condition in one of the following:

- A. Other sections of this data sheet, or
- B. The relevant occupancy-specific data sheet.

2.5.1.3.2 If draft curtains are recommended, install a minimum 2 ft (0.6 m) deep draft curtain that consists of noncombustible materials, such as minimum 26-gauge (0.5 mm) sheet steel, cementitious panels, or gypsum board. If the ceiling is not smooth, fill in the gaps between the topside of the draft curtain and the ceiling if the vertical gap exceeds more than 4 in. (100 mm). Acceptable fill includes sheet steel, cementitious panels, gypsum board, mineral wool, ceramic fiber, or an FM Approved firestop material.

### 2.5.1.4 Solid Mezzanines

See the flowchart in Figure 2.5.1.4 for guidelines involving the installation of sprinklers under solid mezzanines.

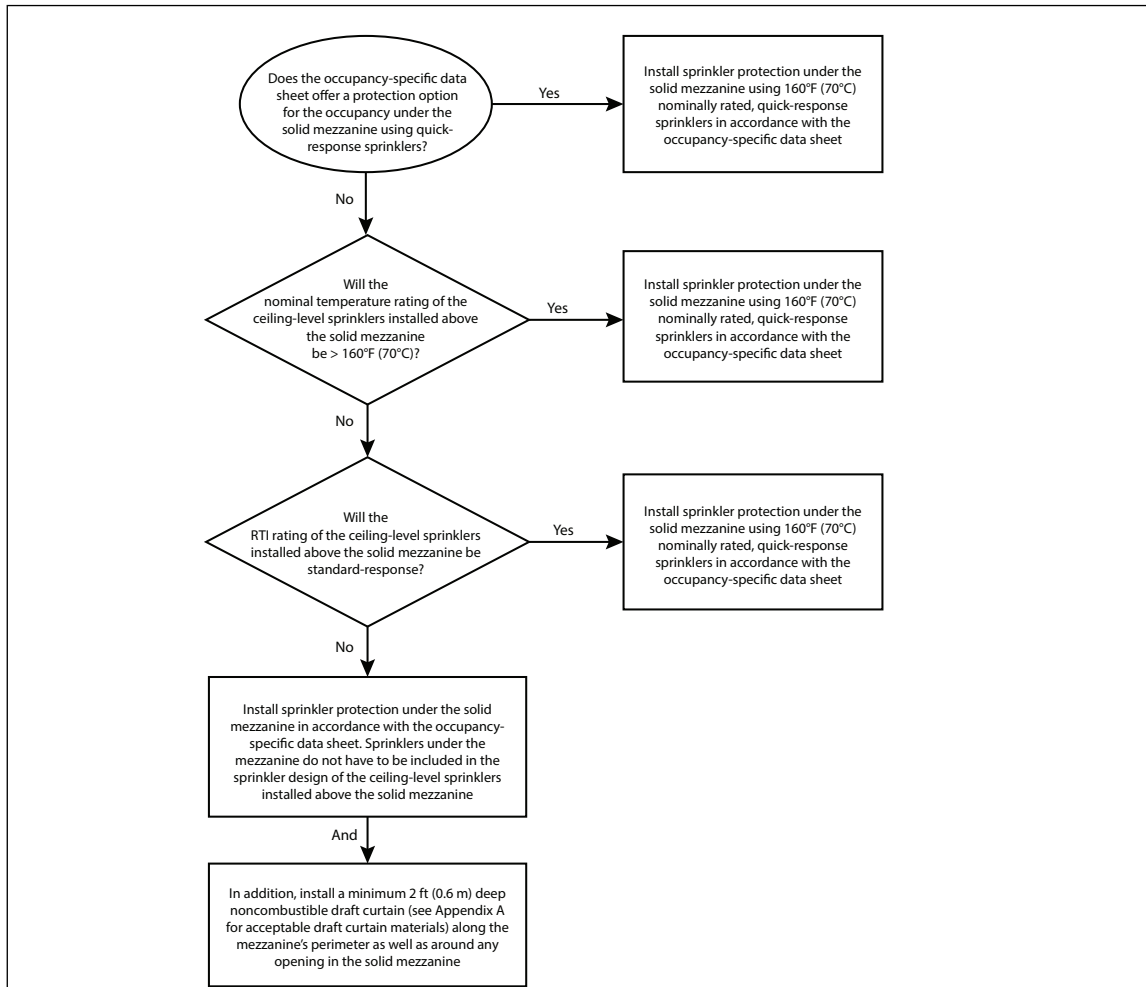

Fig. 2.5.1.4. Installation guidelines for sprinklers under a solid mezzanine]

### 2.5.1.5 Solid Walkways

2.5.1.5.1 Install sprinklers under a solid walkway using the same ceiling-level sprinklers located over the walkway, but with the following exceptions:

- A. The RTI rating of the sprinklers under the walkway is quick-response, and
- B. The nominal temperature rating of the sprinklers under the walkway is 160°F (70°C).

Use the same sprinkler branch line pipe arrangement installed at ceiling level to feed the sprinklers under the walkway.

2.5.1.5.2 As an alternative to Section 2.5.1.5.1, the size of the branch line pipe feeding the sprinklers under the walkway can be determined by using the sprinkler design for the occupancy adjacent to the walkway along with the height of the walkway.

2.5.1.5.3 Sprinklers installed under the solid walkway do not need to be included in the hydraulic design of the ceiling sprinkler system located above it.

2.5.1.5.4 Protect solid walkways wider than 10 ft (3.0 m) in accordance with the recommendations for a solid mezzanine in Section 2.5.1.4.

### 2.5.1.6 Combustible Concealed Spaces

2.5.1.6.1 See Data Sheet 1-12, *Ceilings and Concealed Spaces*, for recommendations on sprinklers under combustible suspended ceilings and within combustible concealed spaces.

2.5.1.6.2 See Data Sheet 3-26, *Fire Protection for Nonstorage Occupancies*, for recommended designs for sprinklers installed under combustible suspended ceilings and within combustible concealed spaces.

### 2.5.1.7 Protection of Wall and Floor Openings

#### 2.5.1.7.1 Protection of Conveyor Openings

2.5.1.7.1.1 Protect conveyor openings using FM Approved open-type water spray nozzles as indicated in Sections 2.5.1.7.1.2 through 2.5.1.7.1.6. Note that quick-response automatic sprinklers can be used to protect a conveyor opening going through a fire partition (wall), as shown in Figure 2.5.1.7.1.1, if the size of the conveyor opening does not exceed 8 ft<sup>2</sup> (0.75 m<sup>2</sup>).

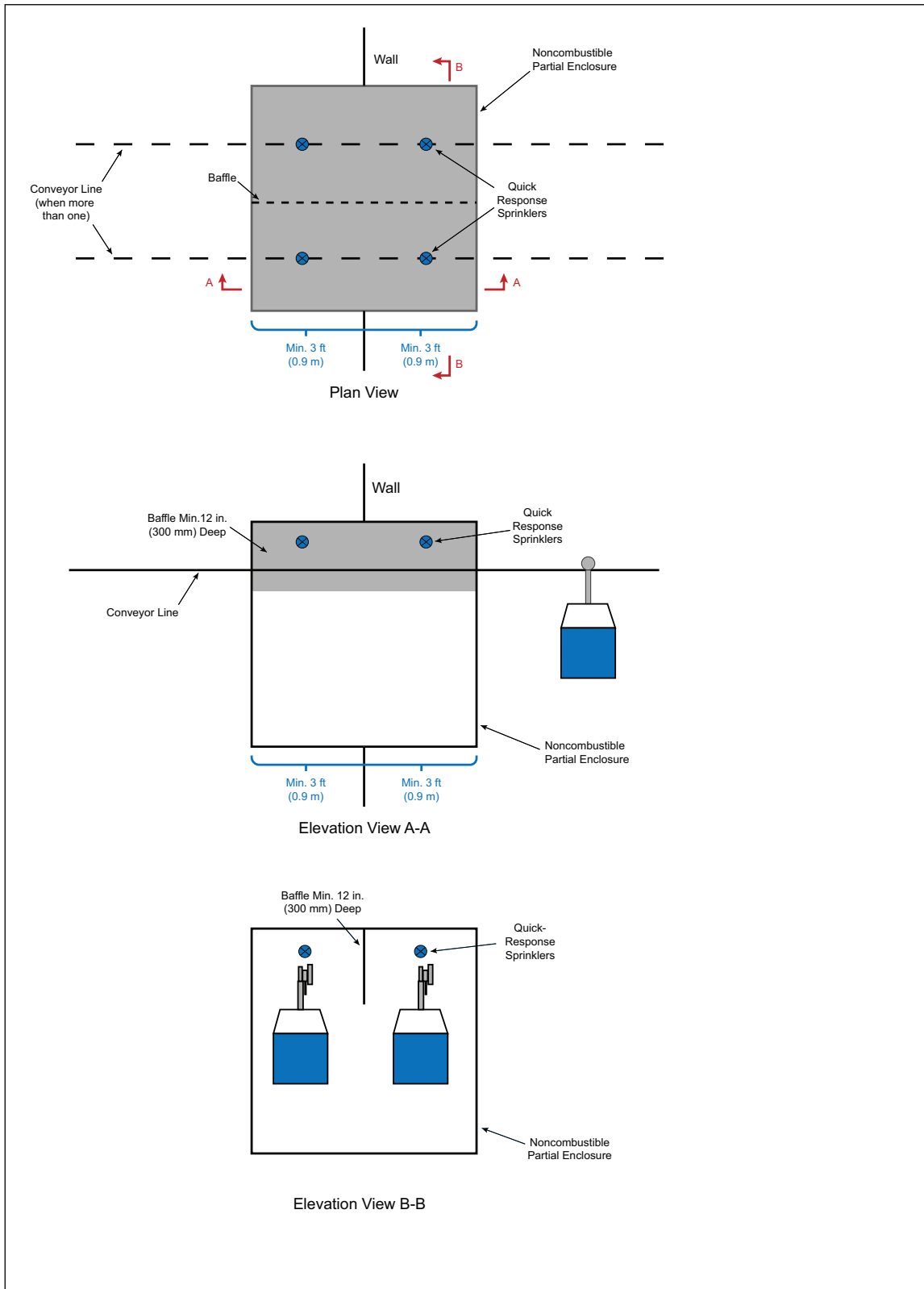

Fig. 2.5.1.7.1.1. Protection of small conveyor openings using quick-response automatic sprinklers

2.5.1.7.1.2 Protect conveyor openings in walls in accordance with Figure 2.5.1.7.1.2 if material handling via the conveyor passes through the wall opening in only one direction.

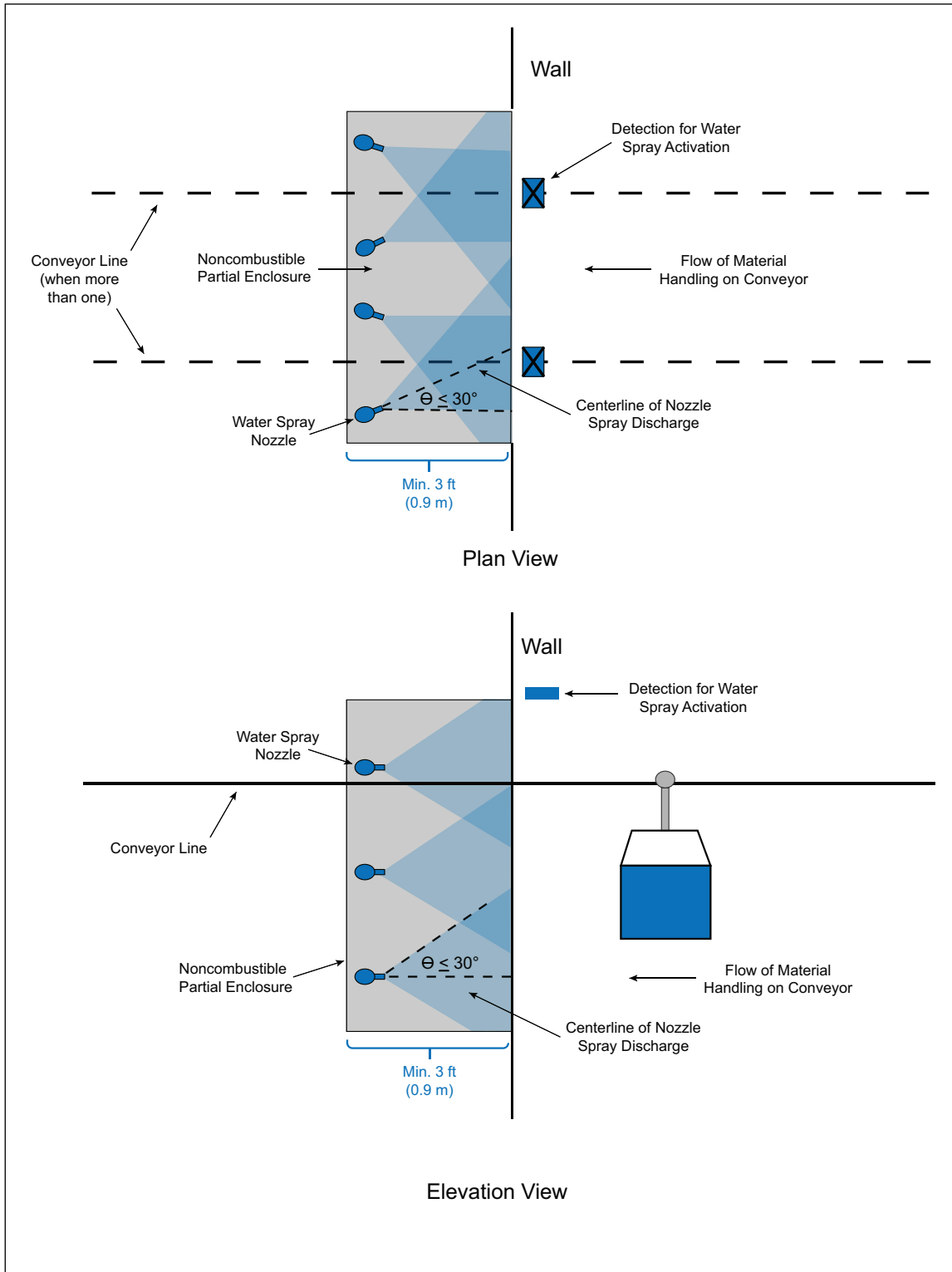

Fig. 2.5.1.7.1.2. Protection of conveyor opening in a wall with flow of material handling through the opening only in one direction

2.5.1.7.1.3 Protect conveyor openings in walls in accordance with Figure 2.5.1.7.1.3 if material handling via the conveyor passes through the wall opening in both directions.

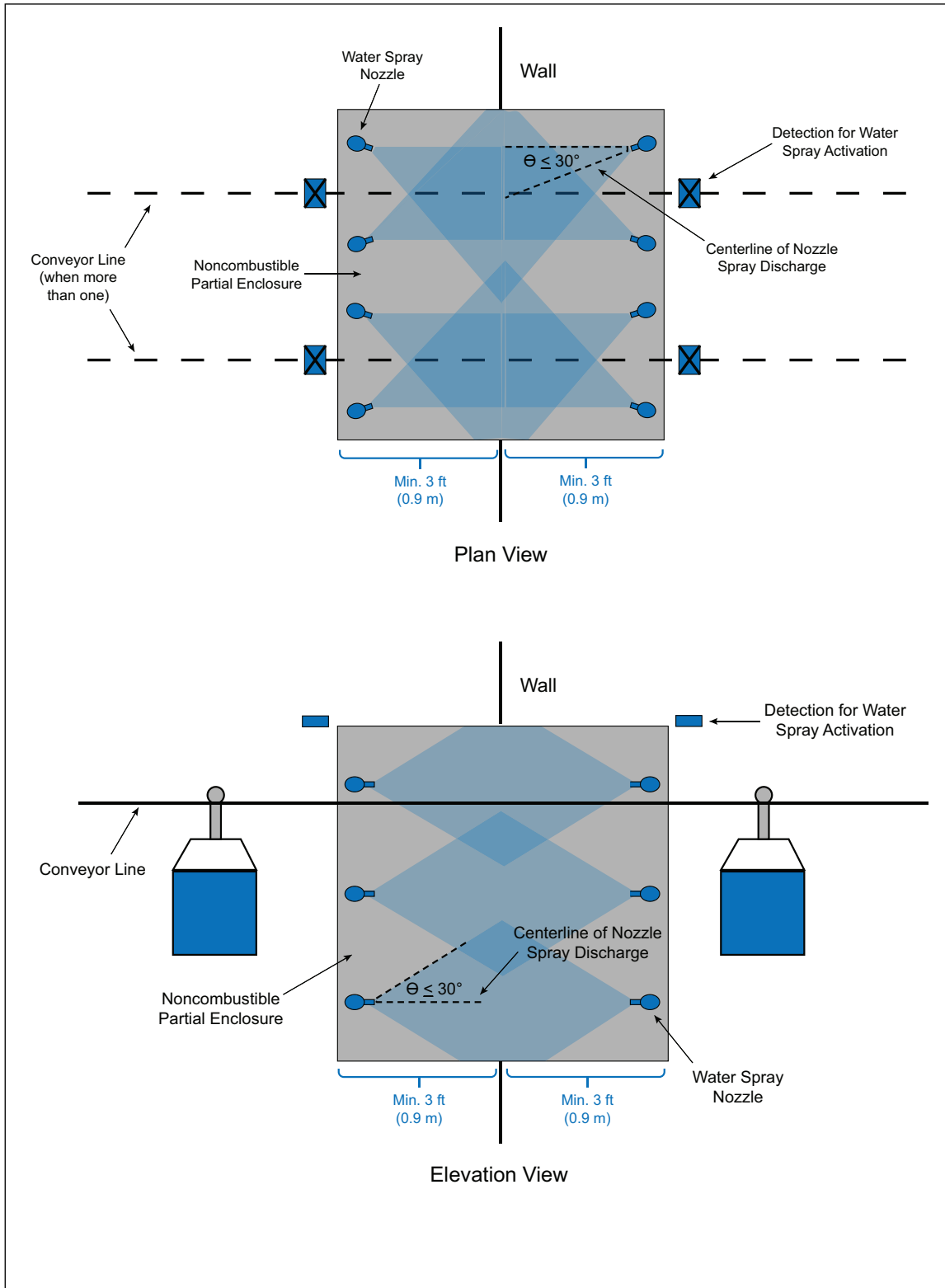

Fig. 2.5.1.7.1.3. Protection of conveyor opening in a wall with flow of material handling through the opening in both directions

### 2.5.1.7.1.4 Protect conveyor openings in floors/ceilings in accordance with Figure 2.5.1.7.1.4.

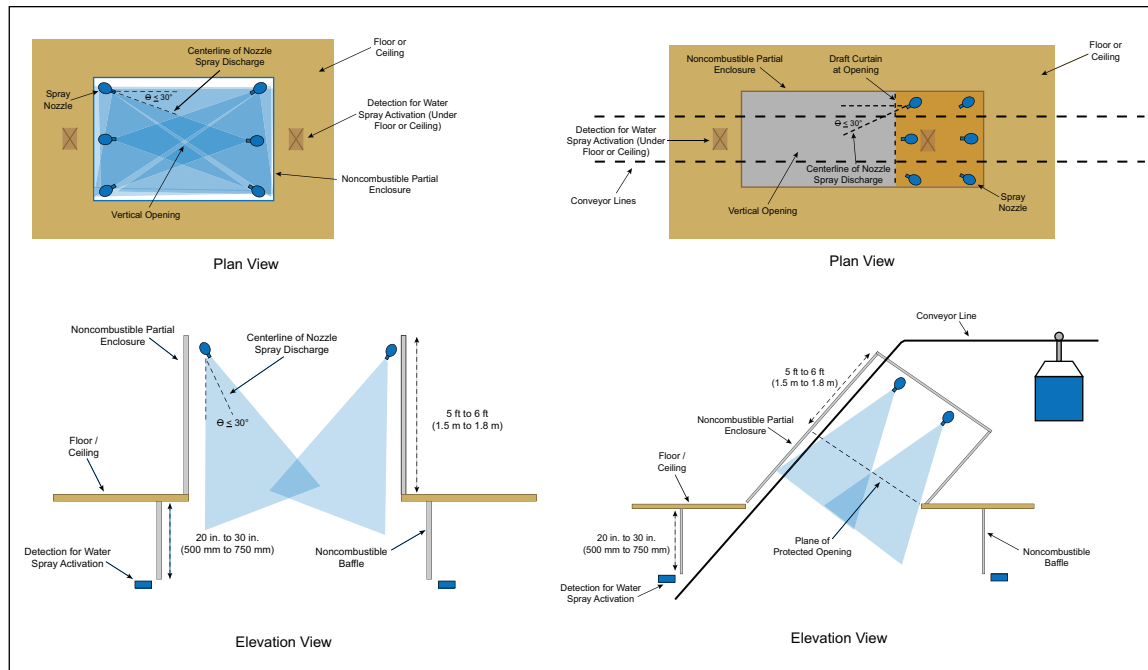

Fig. 2.5.1.7.1.4. Protection of conveyor opening in a floor/ceiling: vertical opening on left; inclined opening on right

### 2.5.1.7.1.5 Arrange the water spray systems for the protection of openings as follows:

- A. Use a separate water spray system on each side of an opening, and
- B. Feed each water spray system from the sprinkler system located on the same side of the opening as the water spray system, and
- C. Provide a control valve as a means of isolating the water spray system from the sprinkler system, and
- D. Use FM Approved quick-response pilot sprinklers or rate-of-rise detection for water spray system activation and install them on the opposite side of the opening where the nozzles they are activating are located, and
- E. Position the water spray nozzles from the opening no more than the distances obtained from Table 2.5.1.7.1.6(b), and
- F. Choose the number of nozzles and the discharge angles such that the opening is well covered with dense spray.

### 2.5.1.7.1.6 Design the water spray systems for the protection of openings as follows:

- A. Design the water spray system using the minimum discharge densities indicated in Table 2.5.1.7.1.6(a) while at the same time providing a minimum spray nozzle pressure of 25 psi (1.7 bar), and
- B. Position the water spray nozzles from the opening in accordance with Table 2.5.1.7.1.6(b), and
- C. Account for the water spray system flowing simultaneously with the sprinkler system located adjacent to and on the opposite side of the opening.

Table 2.5.1.7.1.6(a). Recommended Minimum Discharge Density from Spray Nozzles

Opening Height Above Floor <sup>1</sup> , ft (m)	Discharge Density for Each Opening, gpm/ft <sup>2</sup> (mm/min)
< 15 (4.6)	2 (80)
< 20 (6.1)	2.5 (100)
< 30 (9.1)	3 (120)
≥ 30 (9.1)	4 (160)

Note 1. As measured from the floor to the top of the opening.

Table 2.5.1.7.1.6(b). Recommended Maximum Mounting Distance of Spray Nozzles from Protected Openings With Enclosures

Individual Nozzle Discharge Rate, gpm (L/min)	Maximum Horizontal Distance from Opening, ft (m)
≤ 15 (57)	5.5 (1.7)
≤ 25 (95)	7 (2.1)
≤ 35 (132)	8 (2.4)
> 35 (132)	9 (2.7)

### 2.5.1.7.2 Elevator Hoistways

2.5.1.7.2.1 Sprinkler protection can be avoided in the bottom of an elevator hoistway if the elevator shaft is:

- A. Enclosed, and
- B. Noncombustible, and
- C. Void of any combustible hydraulic fluids and
- D. The elevator belt is noncombustible or of limited-combustibility.

2.5.1.7.2.2 If the requirements of Section 2.5.1.7.2.1 are not met, protect the bottom of the elevator shaft with the installation of minimum K5.6 (K80) sidewall sprinklers having a nominal temperature rating of 212°F (100°C) or less no more than 2 ft (0.6 m) above the floor of the pit.

2.5.1.7.2.3 Sprinkler protection can be avoided in the top of an elevator hoistway if the elevator shaft is:

- A. Specific for passengers, and
- B. Noncombustible or limited-combustible, and
- C. The car enclosure materials meet the requirements of ASTM A17.1, *Safety Code for Elevators and Escalators*, and
- D. The elevator belt is noncombustible or of limited-combustibility.

2.5.1.7.2.4 If the requirements of Section 2.5.1.7.2.3 are not met, protect the top of the elevator shaft with the installation of minimum K5.6 (K80) sprinklers having a nominal temperature rating of 212°F (100°C) or less.

### 2.5.1.7.3 Vertically Enclosed Shafts

2.5.1.7.3.1 Sprinkler protection can be avoided in vertically enclosed shafts if the shaft is:

- A. Noncombustible or is of limited-combustibility, and
- B. Inaccessible, and
- C. Is utilized as an air duct, electrical shaft, or a mechanical shaft.

2.5.1.7.3.2 If the requirements of Section 2.5.1.7.3.1 are not met, protect the top of the vertically enclosed shaft with the installation of a minimum K5.6 (K80) sprinkler having a nominal temperature rating of 212°F (100°C) or less.

2.5.1.7.3.3 If the vertically enclosed shaft has combustible surfaces, in addition to installing a sprinkler at the top of the shaft, install a minimum K5.6 (K80) sprinkler having a nominal temperature rating of 212°F (100°C) or less at each alternate floor level.

2.5.1.7.3.4 If a vertically enclosed shaft with combustibles surfaces is trapped, in addition to the recommendations in Section 2.5.1.7.3.2 and Section 2.5.1.7.3.3, install an additional minimum K5.6 (K80) sprinkler having a nominal temperature rating of 212°F (100°C) or less at the top of each trapped section of the shaft.

2.5.1.7.3.5 If vertically enclosed shafts are accessible, protect the bottom of the vertically enclosed shaft with a minimum K5.6 (K80) sidewall sprinkler having a nominal temperature rating of 212°F (100°C) or less no more than 2 ft (0.6 m) above the bottom of the shaft.

#### 2.5.1.7.4 Non-Enclosed Vertical Floor Openings

2.5.1.7.4.1 A non-enclosed vertical floor opening does not need a combination of draft curtains and closely spaced sprinklers if:

- A. The floor opening joins spaces/floor levels that are protected by ceiling sprinklers in accordance with FM Property Loss Prevention Data Sheets, and
- B. The horizontal distance between opposite ends of the opening is a minimum of 20 ft (6.1 m) in all directions, and
- C. The area size of the opening is a minimum of 1,000 ft<sup>2</sup> (93 m<sup>2</sup>).

2.5.1.7.4.2 If the requirements of Section 2.5.1.7.4.1 are not met, install draft curtains in accordance with Section 2.5.1.7.4.3 and closely spaced sprinklers in accordance with Section 2.5.1.7.4.4 and Section 2.5.1.7.4.5.

2.5.1.7.4.3 If Section 2.5.1.7.4.2 indicates draft curtains are recommended, install noncombustible or limited-combustible draft curtains that are a minimum 18 in. (450 mm) deep and located immediately adjacent to the opening.

2.5.1.7.4.4 If Section 2.5.1.7.4.2 indicates that closely spaced sprinklers are recommended, install sprinklers 6 ft (1.8 m) apart along the opening as follows:

- A. Use the same sprinklers being installed under the ceiling adjacent to the opening, but use quick-response sprinklers if standard-response sprinklers are being installed under the adjacent ceiling, and
- B. Position the sprinklers so that they are 6 to 12 in. (150 to 300 mm) horizontally away from the draft curtain.

2.5.1.7.4.5 If the spacing between sprinklers in Section 2.5.1.7.4.4 will be less than 6 ft (1.8 m), install noncombustible or limited-combustible baffles midway between the sprinklers as follows:

- A. Size the baffles so they are at least 8 in. (200 mm) in length and at least 6 in. (150 mm) tall, and
- B. Position the baffles so they extend 2 to 3 in. (50 to 75 mm) above the top of upright sprinklers and position the baffles even with the deflectors if pendent sprinklers are installed.

#### 2.5.1.7.5 Stairways

2.5.1.7.5.1 Install sprinklers beneath all stairways having combustible construction.

2.5.1.7.5.2 Install sprinklers beneath all landings if the area is used for storage.

2.5.1.7.5.3 In noncombustible stair shafts having noncombustible stairs with noncombustible or limited-combustible finishes, install sprinklers at the top of the stairway shaft and under the first accessible landing above the bottom of the shaft.

2.5.1.7.5.4 Install sprinklers for each stairway floor landing where an access door is provided.

#### 2.5.1.7.6 Escalators

2.5.1.7.6.1 Install sprinklers to protect floors served by escalators if the construction or occupancy is combustible.

2.5.1.7.6.2 Install quick-response sprinklers along the periphery of an escalator as demonstrated in Figure 2.5.1.7.6.2 if a ceiling is located over the entrance and exit points of the escalator at each floor level.

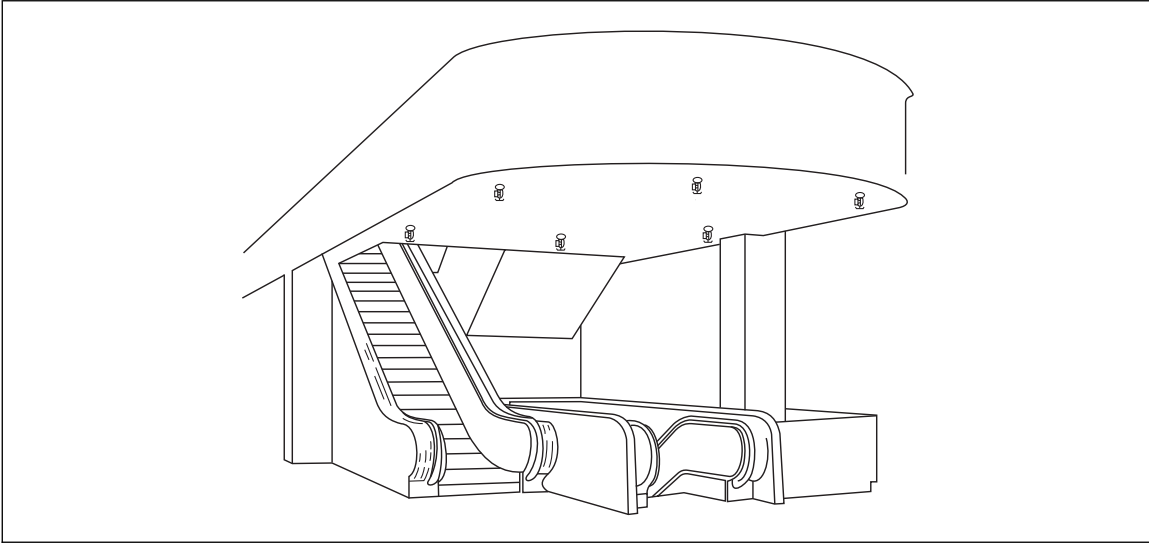

Fig. 2.5.1.7.6.2. Protection of an escalator with a ceiling over the entrance and exit points of the escalator at each floor level

2.5.1.7.6.3 If a ceiling is not provided over the entrance and exit points of an escalator at each floor level, protect the vertical opening created by the escalator in accordance with Section 2.5.1.7.4.

#### 2.5.1.7.7 Windows

2.5.1.7.7.1 Where windows are installed in fire-rated walls, protect against fire spread through the window as follows:

- A. Install a window that is listed for a duration equal to at least 75% of the fire partition in which it will be installed, and
- B. The glass/glazing of the window is listed for use in fire barriers with a minimum one-hour fire rating, and
- C. The window frame is listed with a minimum one-hour fire rating, and
- D. A clear space free of combustibles in accordance with Figure 2.5.1.7.7.1.

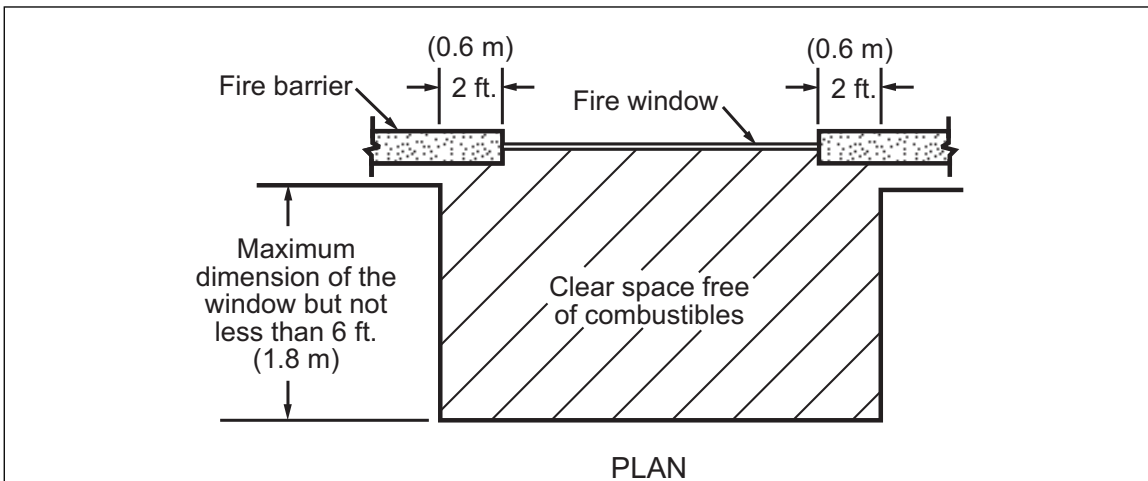

Fig. 2.5.1.7.7.1. Recommended void area of combustibles for windows not protected by sprinklers

2.5.1.7.7.2 Where the requirements of Section 2.5.1.7.7.1 are not met, protect the windows using sprinklers either by (a) installing open-head type minimum K5.6 (K80) pendent sprinklers on a deluge sprinkler system, or by (b) installing 165°F (70°C) nominally rated quick-response minimum K5.6 (K80) pendent sprinklers on a wet-pipe sprinkler system. Arrange the piping and control of the window sprinkler system as recommended for an in-rack sprinkler system.

2.5.1.7.7.3 Where a deluge sprinkler system is being utilized, trip the deluge system using combination rate-of-rise, fixed-temperature (nominal 135°F [57°C] rated) heat-actuated detectors. Locate the detectors just above the window sprinklers at ceiling/roof level, but at least 6 in. (150 mm) from the wall and a maximum of 10 ft (3.0 m) on center parallel to the window.

2.5.1.7.7.4 Install the pendent sprinklers on spacing ranging from 6 to 10 ft (1.8 to 3.0 m) on center and positioned adjacent to and near the top of the windows, but at least 6 in. (150 mm) below the ceiling. Arrange the sprinkler's deflector so that it is facing parallel to the window and located about 12 in. (300 mm) horizontally from it.

2.5.1.7.7.5 Install baffles between ceiling sprinklers and window sprinklers if they are closer than 6 ft (1.8 m) apart.

2.5.1.7.7.6 Where window heights exceed 13 ft (4.0 m), provide an additional level(s) of window sprinklers with water shields, with each level of sprinklers covering an approximately equal vertical area below them.

2.5.1.7.7.7 Design the window sprinkler system to provide a minimum flow of 4 gpm per linear foot (50 L/min/m) of window width. Arrange the water supply to account for the simultaneous flow of the ceiling sprinkler system adjacent to the windows, the hose demand indicated for the ceiling sprinkler system, and the window sprinkler system.

### 2.5.1.8 Automatic Shutdown of Conveyors and Conveying Systems

Arrange conveyor systems to shut down automatically upon sprinkler system waterflow.

### 2.5.1.9 Clearance Below Ceiling-Level Sprinklers

2.5.1.9.1 Maintain a minimum 3 ft (0.9 m) clearance between combustibles and standard-coverage ceiling-level sprinkler deflectors.

2.5.1.9.2 Maintain a minimum 5 ft (1.5 m) clearance between combustibles and extended-coverage ceiling-level sprinkler deflectors.

### 2.5.1.10 Protecting Sprinklers from Damage

2.5.1.10.1 Provide protection for sprinklers that are subject to mechanical damage. Protection can be in the form of FM Approved sprinkler cages, steel framing, concrete posts, etc. if the protection provided complies with the obstruction guidelines for the sprinkler being protected.

#### 2.5.1.10.2 Protecting Dry-Pendent Sprinklers

2.5.1.10.2.1 If dry-pendent sprinklers are installed to protect a cold or freezer area and fed from a wet-pipe sprinkler system, maintain a minimum 12 in. (300 mm) vertical distance between the top of the area's ceiling and the overhead sprinkler piping that will feed the dry-pendent sprinklers.

2.5.1.10.2.2 As a means of preventing water accumulation on the exterior of the dry-pendent sprinkler drop located in the heated area, consider tightly caulking the hole created by the drop, and wrapping the dry-pendent drop located above the ceiling with thermal mastic tape (or equivalent).

#### 2.5.1.11 Return Bends for Sprinklers

2.5.1.11.1 Install minimum 1 in. (25 mm) individual return bends for all K11.2 (K160) or smaller pendent sprinklers that are supplied from a raw water source, a mill pond, or from an open-top reservoir. See Figure 2.5.1.11.1 for an example of a return bend.

2.5.1.11.2 Return bends are not needed for:

- A. A sprinkler system that is equipped with an FM Approved strainer, or
- B. A deluge sprinkler system, or

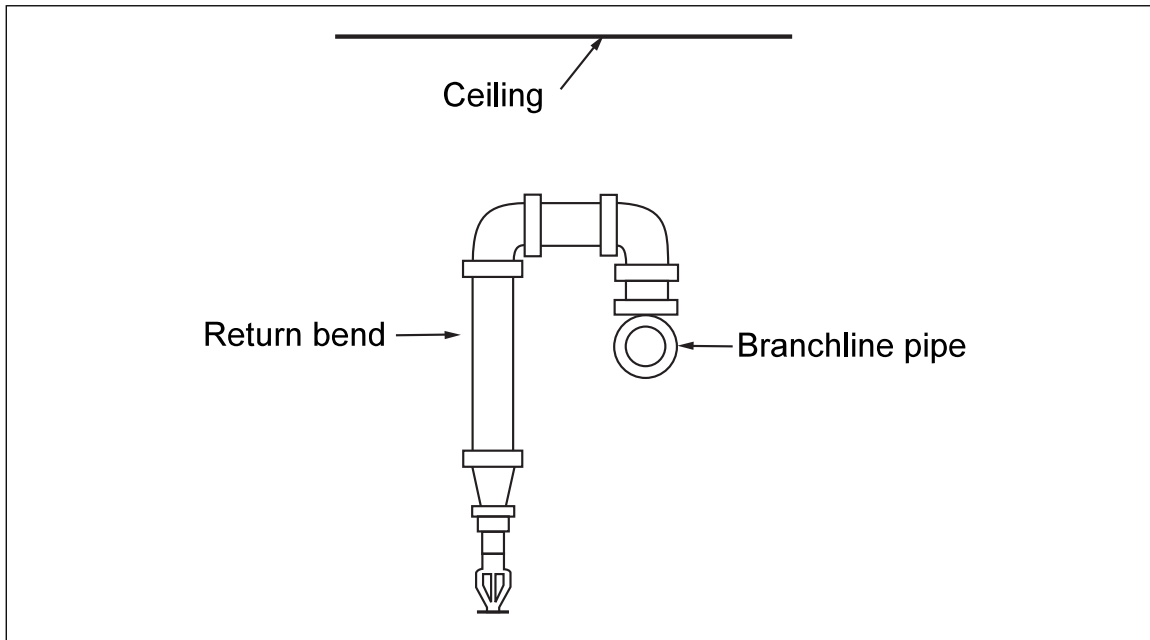

Fig. 2.5.1.11.1. Example of a return bend for Nonstorage sprinklers

C. Dry-pendent sprinklers.

#### 2.5.1.12 Frame Arms of Upright Sprinklers

Install upright sprinklers so their frame arms are parallel to the branch line.

#### 2.5.1.13 Spare Sprinklers

2.5.1.13.1 Maintain a supply of spare sprinklers on site for each type of sprinkler installed, and any equipment required for installing them.

2.5.1.13.2 The minimum number of spare sprinklers to maintain on site is based on the largest number of sprinklers required in the sprinkler system design area for which they are used.

### 2.5.2 Nonstorage Pendent and Upright Sprinklers

#### 2.5.2.1 General Recommendations for Nonstorage Pendent and Upright Sprinklers

See Figure 2.5.2.1 to assist in determining what Nonstorage pendent and upright sprinklers can be installed for a given occupancy when the relevant occupancy-specific data sheet indicates it can be treated as nonstorage.

##### 2.5.2.1.1 Determining Acceptable K-factor for Nonstorage Pendent and Upright Sprinklers

Table 2.5.2.1.1(a) indicates the K-factors for Nonstorage pendent and upright sprinklers. Table 2.5.2.1.1(b) indicates the minimum allowable K-factor values depending on the recommended sprinkler system design.

Table 2.5.2.1.1(a). Nominal K-factor Values of FM Approved Nonstorage Sprinklers

Nominal K-factor Values, $\text{gpm}/(\text{psi})^{0.5}$ ( $\text{L}/\text{min}/[\text{bar}]^{0.5}$ )	Nominal Pipe Thread Size, in. (mm)
2.8 (40)	1/2 or 3/4 (15 or 20)
5.6 (80)	1/2 or 3/4 (15 or 20)
8.0 (115)	1/2 or 3/4 (15 or 20)
11.2 (160)	1/2 or 3/4 (15 or 20) <sup>1</sup>
14.0 (200)	3/4 (20)
16.8 (240)	3/4 (20)

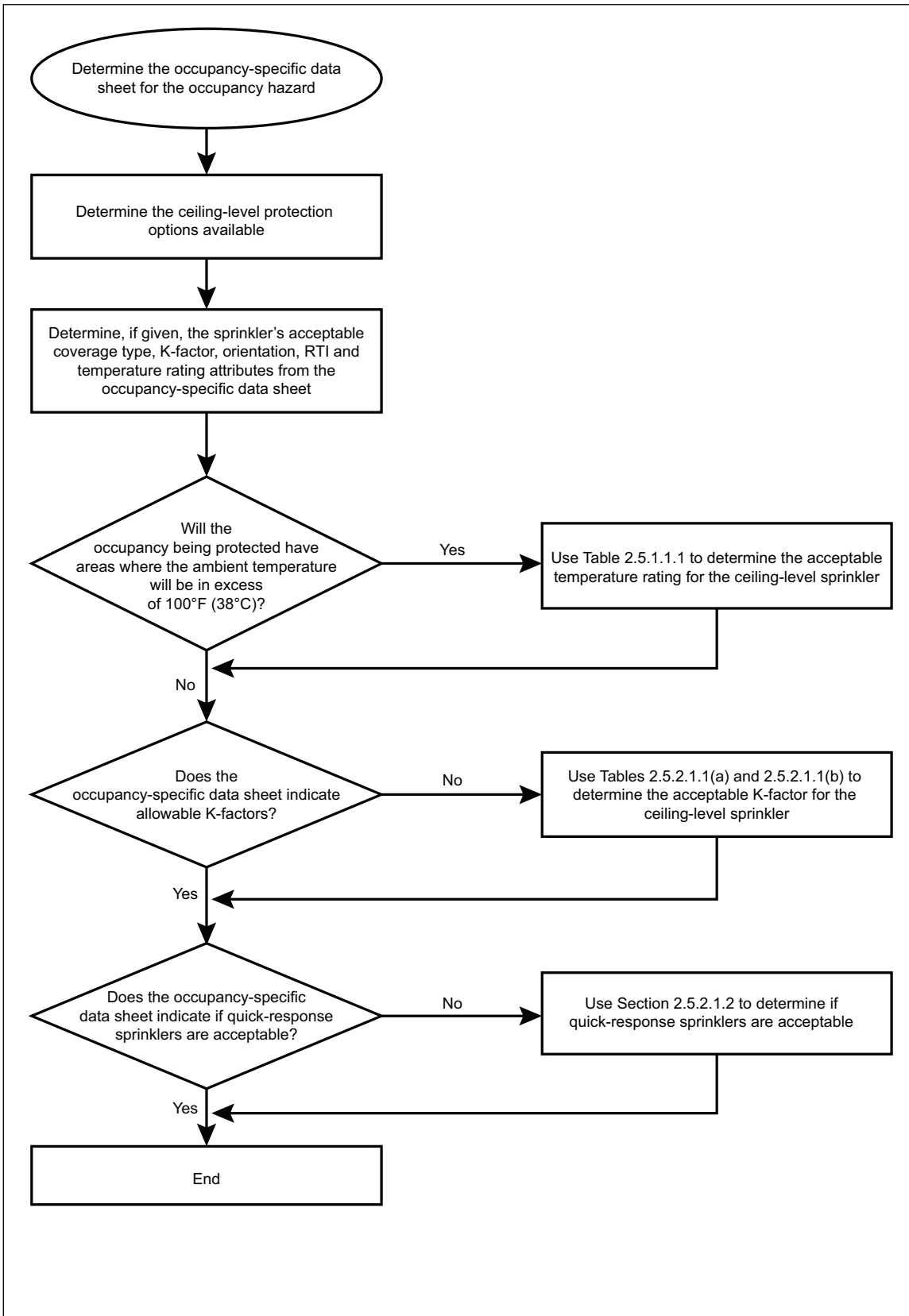

Fig. 2.5.2.1. Flowchart for applicable Nonstorage pendent and upright sprinklers

Nominal K-factor Values, $\text{gpm}/(\text{psi})^{0.5}$ ( $\text{L}/\text{min}/[\text{bar}]^{0.5}$ )	Nominal Pipe Thread Size, in. (mm)
2.8 (40)	1/2 or 3/4 (15 or 20)
19.6 (280)	1 (25)
22.4 (320)	1 (25)
25.2 (360)	1 (25)
28.0 (400)	1 (25)
33.6 (480)	1-1/4 (32)

Note 1. The use of K11.2 (K160) sprinklers having nominal 1/2 in. (15 mm) NPT threaded connections is acceptable only if they are being considered as a retrofit option for the replacement of existing K8.0 (K115) or smaller sprinklers.

Table 2.5.2.1.1(b). Recommended Minimum Allowable Nonstorage Pendent and Upright Sprinkler K-factors

Recommended Density from Occupancy-Specific Data Sheet, $\text{gpm}/\text{ft}^2$ (mm/min)	Minimum Recommended Standard-Coverage Ceiling Sprinkler K-factor	Minimum Recommended Extended-Coverage Ceiling Sprinkler K-factor
Density $\leq$ 0.10 (4)	K5.6 (K80)	K5.6EC (K80EC)
0.10 (4) < Density $\leq$ 0.30 (12)	K5.6 (K80)	K11.2EC (K160EC)
Density > 0.30 (12)	K11.2 (K160)	K25.2EC (K360EC)

### 2.5.2.1.2 Determining Acceptable RTI Ratings for Nonstorage Pendent and Upright Sprinklers

2.5.2.1.2.1 The installation of standard-response Nonstorage sprinklers is acceptable for both wet-type and dry-type sprinkler systems.

2.5.2.1.2.2 The installation of quick-response Nonstorage sprinklers is acceptable for wet type sprinkler systems; however, do not use quick-response sprinklers for the following types of nonstorage occupancies:

- A. Spray applications of ignitable liquids
- B. Hydraulic equipment using ignitable liquids
- C. Occupancies involving ignitable liquids other than those incidental to a process and are in safety containers having volume capacities of 5 gallons (19 liters) or less
- D. Vehicle assembly or repair areas where there is fuel in fuel tanks
- E. Occupancies where there are large areas shielded from sprinkler discharge
- F. Areas where oil, dust, lint, or similar combustible residues can accumulate on ceilings and/or building structural support members
- G. Where the occupancy-specific data sheet does not recommend their use for the occupancy being protected

### 2.5.2.1.3 Gravity Heat/Smoke Vents in the Presence of Nonstorage Sprinklers

2.5.2.1.3.1 Do not install gravity heat vents or gravity smoke vents in buildings protected by ceiling-level sprinklers.

2.5.2.1.3.2 If the installation of these types of vents is unavoidable, use the flowchart in Figure 2.5.2.1.3.2(a) when the size of the gravity heat/smoke vent will be equal to or less than 4 ft<sup>2</sup> (0.4 m<sup>2</sup>) or Figure 2.5.2.1.3.2(b) for larger-sized vents.

2.5.2.1.3.3 Where a flat, continuous, false ceiling is to be installed as shown in Figure 2.5.2.1.3.2(c), use minimum 22-gauge (0.7 mm) sheet metal or similar noncombustible material for the false ceiling; and secure it so that it can resist a minimum uplift velocity pressure of 3 lb/ft<sup>2</sup> (14.6 kg/m<sup>2</sup>). A less desirable but acceptable alternative to noncombustible materials includes minimum 3/8 in. (10 mm) plywood (or similar material).

### 2.5.2.1.4 Natural Draft Exhaust Vents in the Presence of Nonstorage Sprinklers

Use the flowchart in Figure 2.5.2.1.4 to determine if corrective action is needed due to the presence of a natural draft exhaust vent.

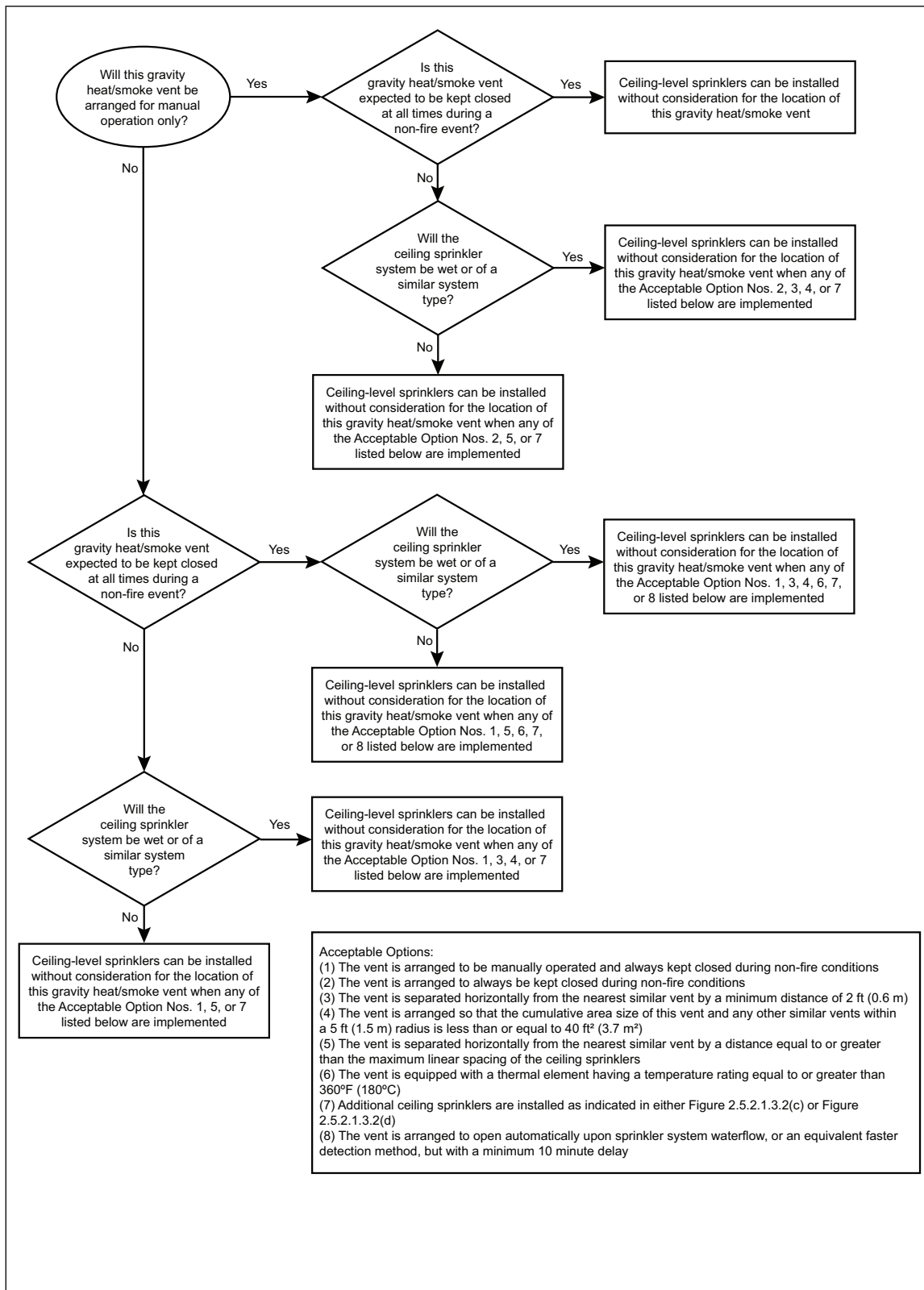

Fig. 2.5.2.1.3.2(a) Flowchart for potential recommendations when a gravity heat/smoke vent less than or equal to 4 ft<sup>2</sup> (0.4 m<sup>2</sup>) in size must be installed over a nonstorage-type occupancy

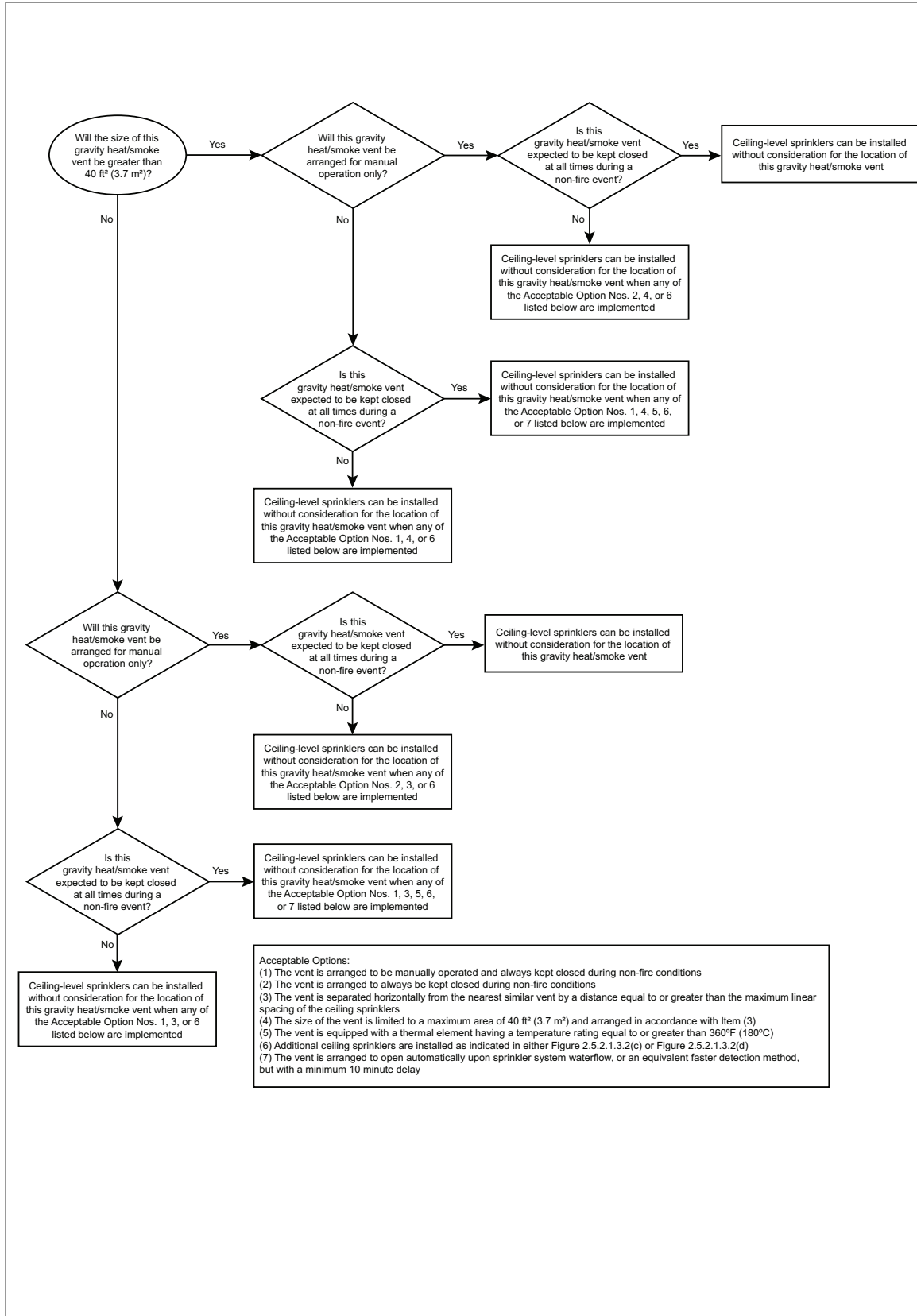

Fig. 2.5.2.1.3.2(b). Flowchart for potential recommendations when a gravity heat/smoke vent larger than 4 ft² (0.4 m²) in size must be installed over a nonstorage-type occupancy

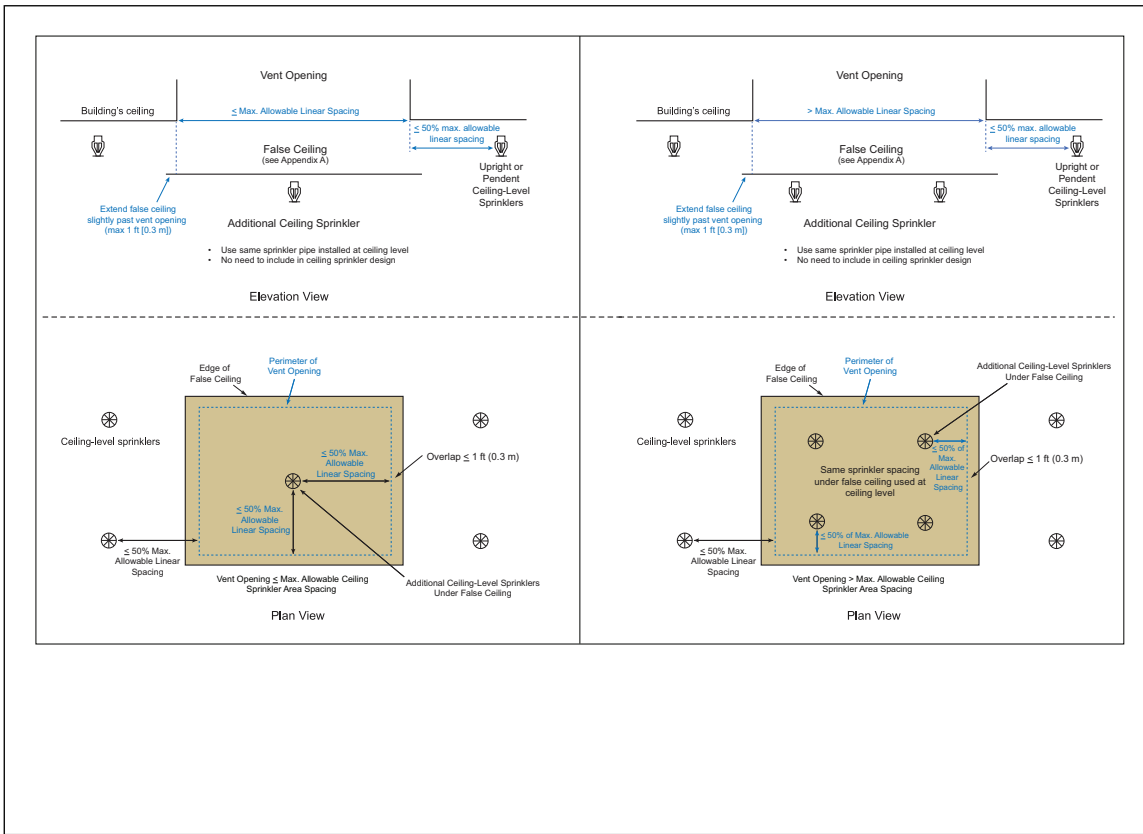

Fig. 2.5.2.1.3.2(c). Protection of vent openings at ceiling level, such as gravity heat/smoke vents, natural draft exhaust vents or mechanical exhaust vents using a flat, continuous, false ceiling and additional ceiling-level sprinklers

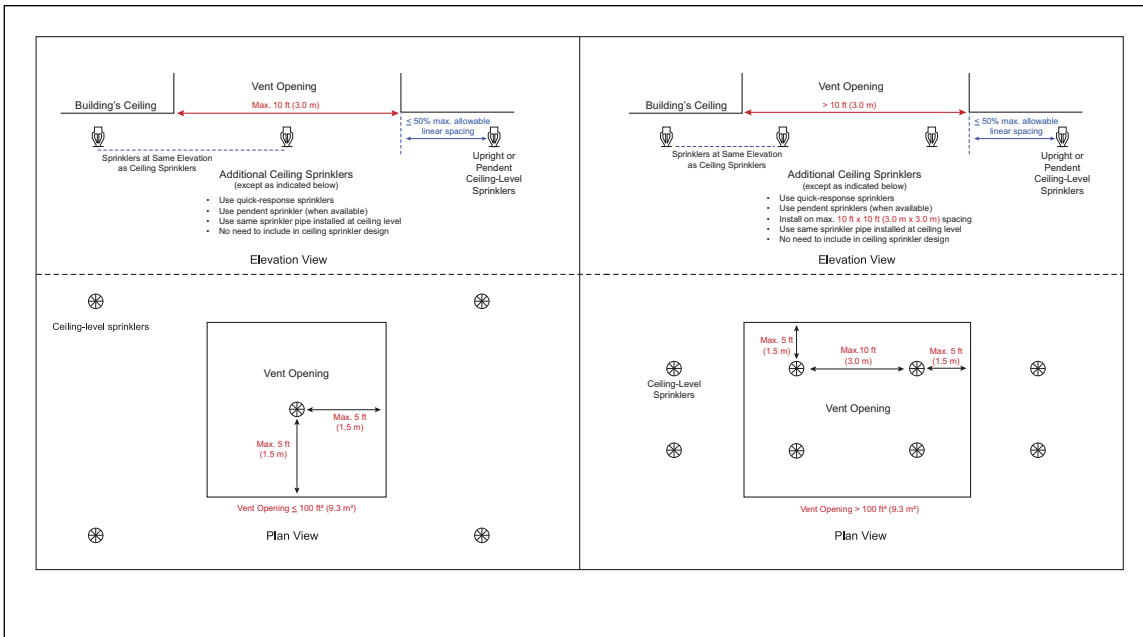

Fig. 2.5.2.1.3.2(d). Protection of vent openings at ceiling level, such as gravity heat/smoke vents, natural draft exhaust vents or mechanical exhaust vents, located over a nonstorage-type occupancy, using additional quick-response ceiling-level sprinklers

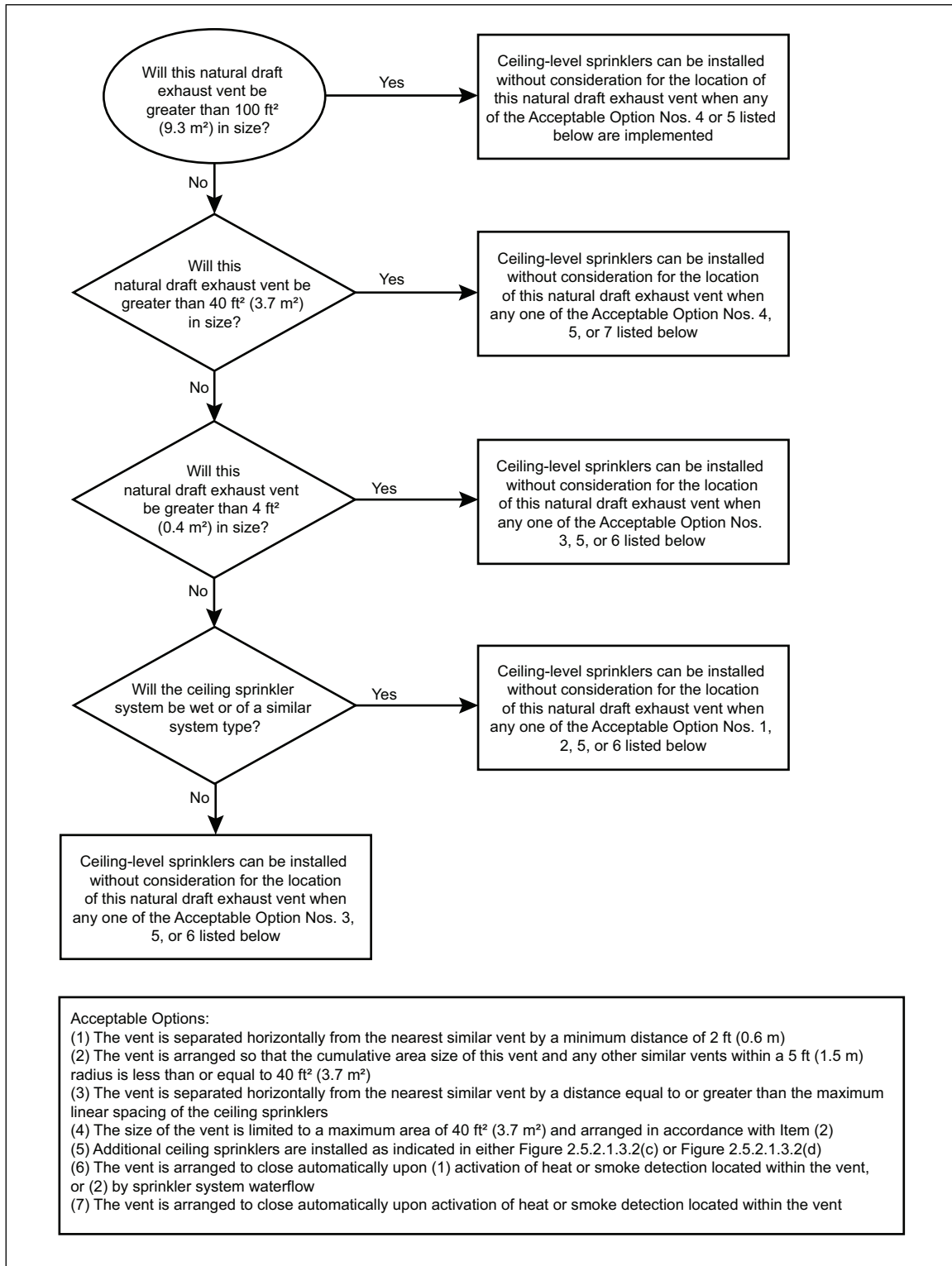

Fig. 2.5.2.1.4. Flowchart for potential recommendations when a natural draft exhaust vent is to be installed over a nonstorage-type occupancy

### 2.5.2.1.5 Mechanical Exhaust Vents in the Presence of Nonstorage Sprinklers

If a mechanical exhaust vent will be installed at ceiling level over a nonstorage-type occupancy, use the flowchart in Figure 2.5.2.1.5 to determine if corrective action is needed due to the presence of the mechanical exhaust vent.

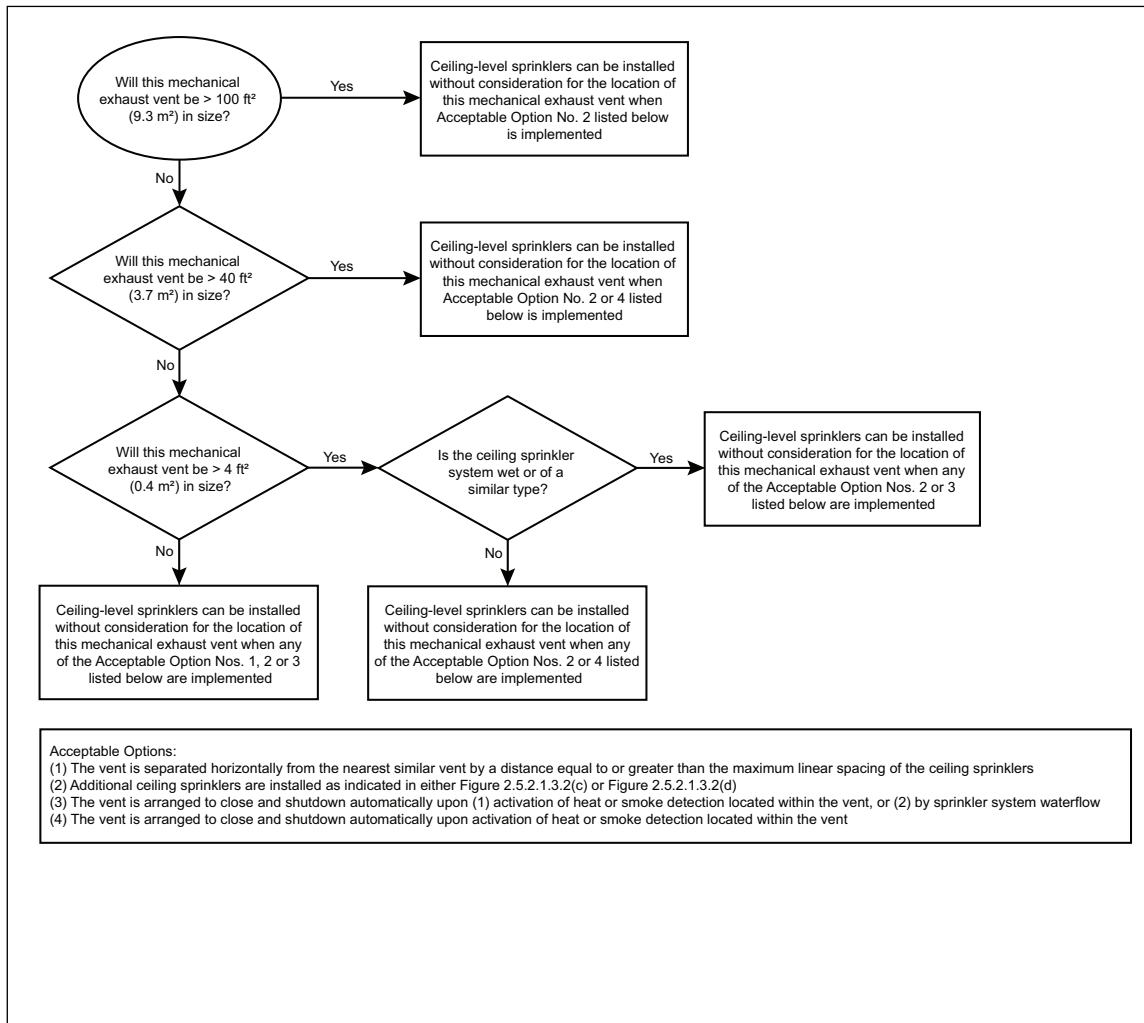

Fig. 2.5.2.1.5. Flowchart for potential recommendations when a mechanical exhaust vent is to be installed over a nonstorage-type occupancy.

### 2.5.2.1.6 Ridge Vents in the Presence of Nonstorage Sprinklers

If a ridge vent will be installed at ceiling level over a nonstorage-type occupancy, see Figures 2.5.2.1.6(a) through Figure 2.5.2.1.6(d) for acceptable ceiling-level sprinkler arrangements, depending on the width of the ridge vent.

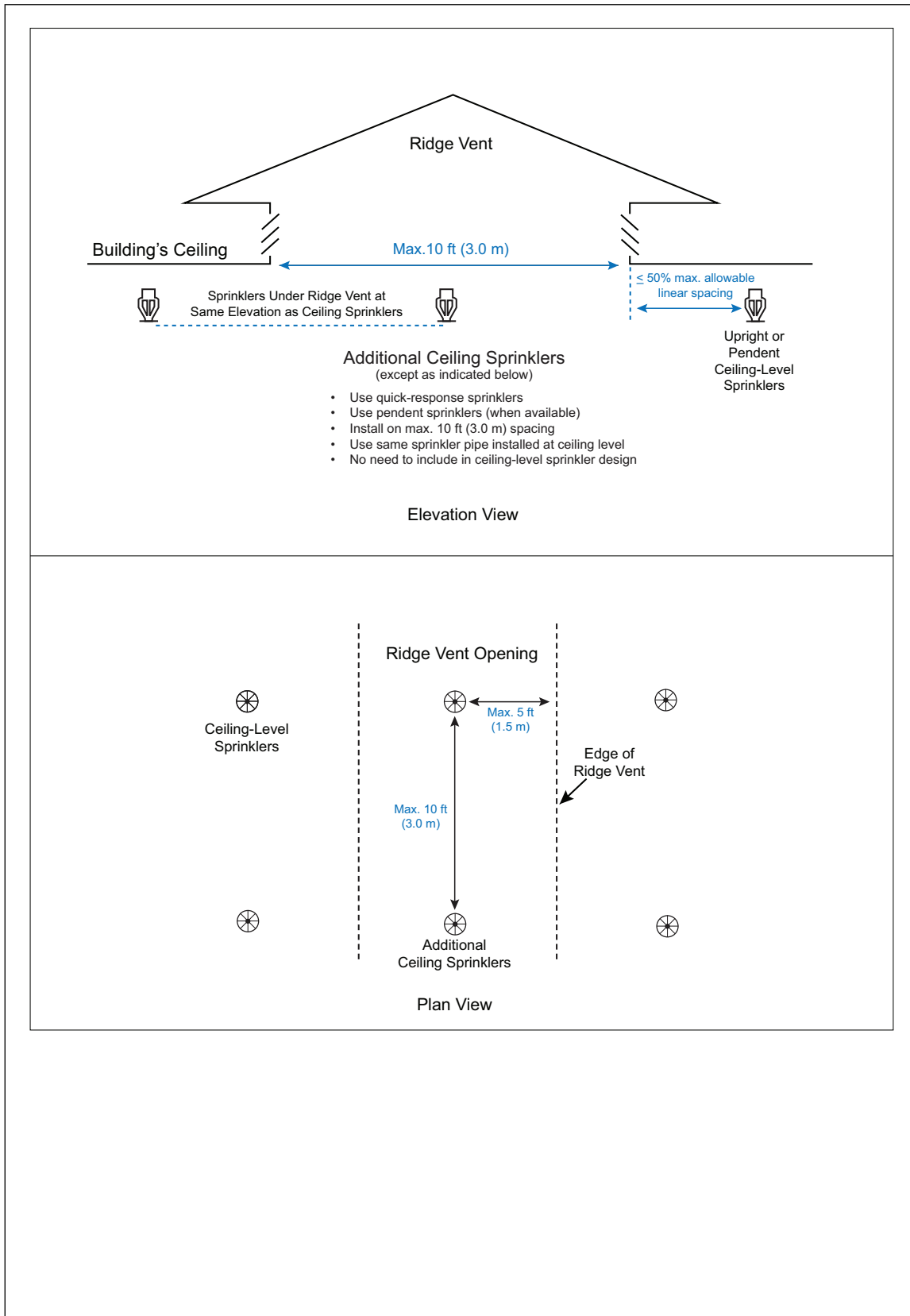

Fig. 2.5.2.1.6(a). Acceptable ceiling-level sprinkler arrangement for the protection of a nonstorage-type occupancy in the presence of a ridge vent up to 10 ft (3.0 m) wide, using additional quick-response ceiling-level sprinklers installed within the footprint of the ridge vent

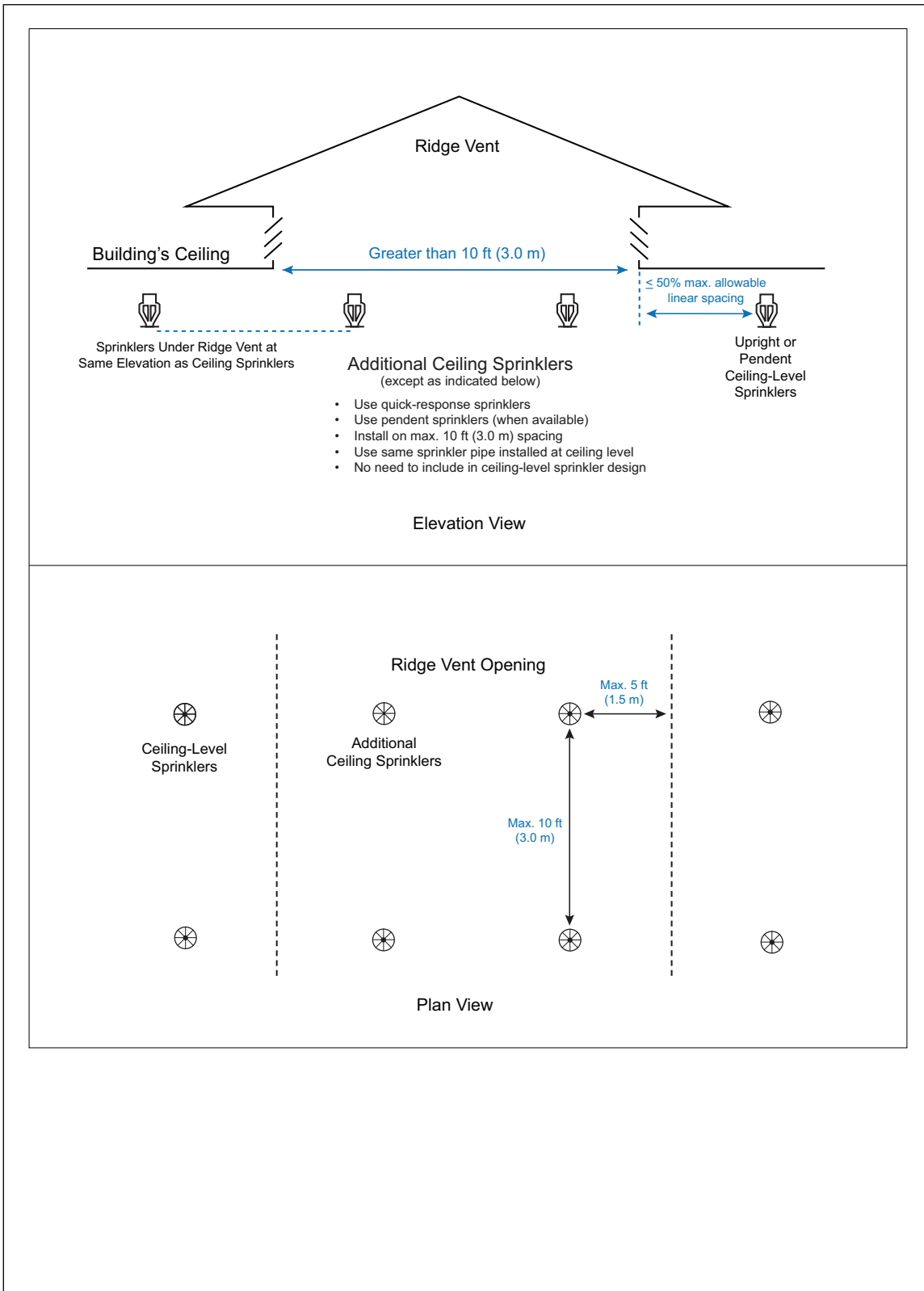

Fig. 2.5.2.1.6(b). Acceptable ceiling-level sprinkler arrangement for the protection of a nonstorage-type occupancy in the presence of a ridge vent greater than 10 ft (3.0 m) wide using additional quick-response ceiling-level sprinklers installed below the ridge vent

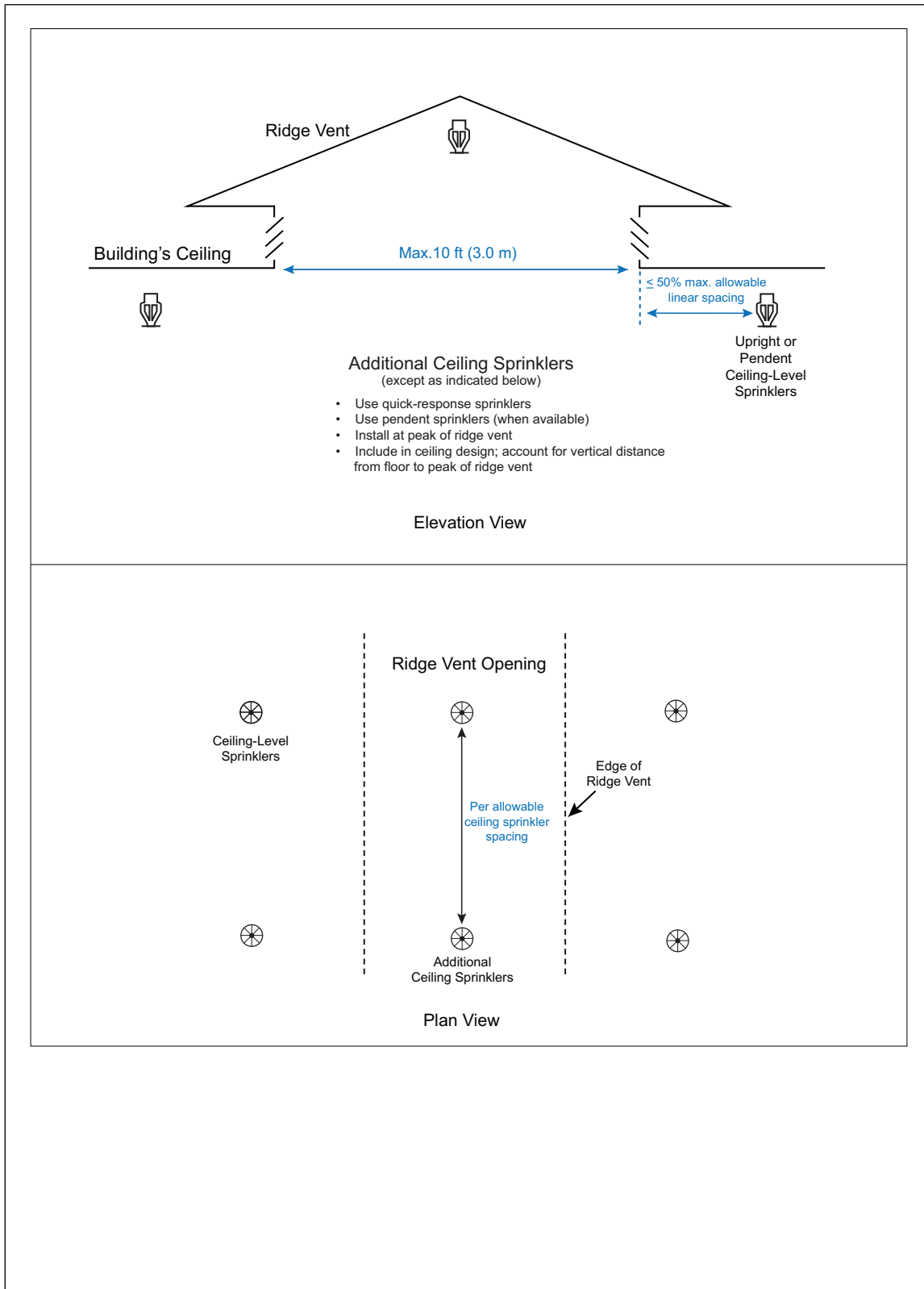

Fig. 2.5.2.1.6(c). Acceptable ceiling-level sprinkler arrangement for the protection of a nonstorage-type occupancy in the presence of a ridge vent up to 10 ft (3.0 m) wide using additional quick-response ceiling-level sprinklers installed within the ridge vent

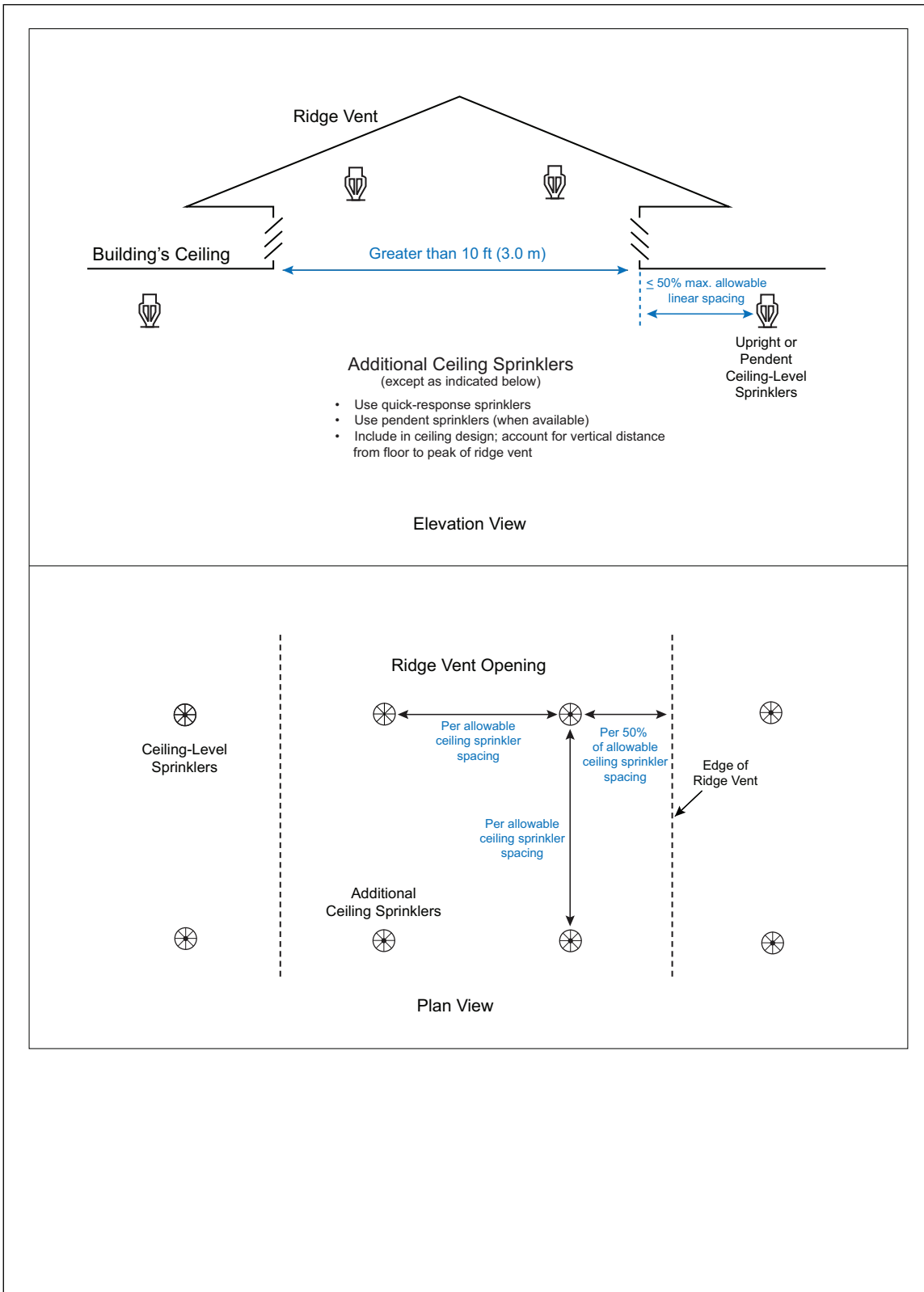

Fig. 2.5.2.1.6(d). Acceptable ceiling-level sprinkler arrangement for the protection of a nonstorage-type occupancy in the presence of a ridge vent greater than 10 ft (3.0 m) wide using additional quick-response ceiling-level sprinklers installed within the ridge vent

**2.5.2.1.7 Skylights in the Presence of Nonstorage Sprinklers**

Install ceiling-level sprinklers below skylights, whether glass or plastic, in the same manner as installing under a noncombustible ceiling.

If the skylight is equipped with a gravity heat/smoke vent, see the recommendations in Section 2.5.2.1.3.

If the skylight is elevated above the adjacent ceiling area, see the recommendations in Section 2.5.2.1.8 to determine if the skylight qualifies as a ceiling pocket. If so, determine whether sprinklers are recommended within the skylight.

**2.5.2.1.8 Ceiling Pockets in the Presence of Nonstorage Pendent and Upright Sprinklers**

See the flowchart in Figure 2.5.2.1.8 to determine whether sprinklers are recommended within the footprint of a ceiling pocket in addition to being installed under the main lower ceiling of the protected area.

If the flowchart indicates that sprinklers are recommended within the ceiling pocket, install the sprinklers based on the guidelines indicated for the maximum ceiling height of the ceiling pocket. Note that the minimum allowable horizontal distances between sprinklers in the ceiling pocket and those located below the main ceiling can be ignored. However, the maximum allowable horizontal distances between these sprinklers cannot be ignored.

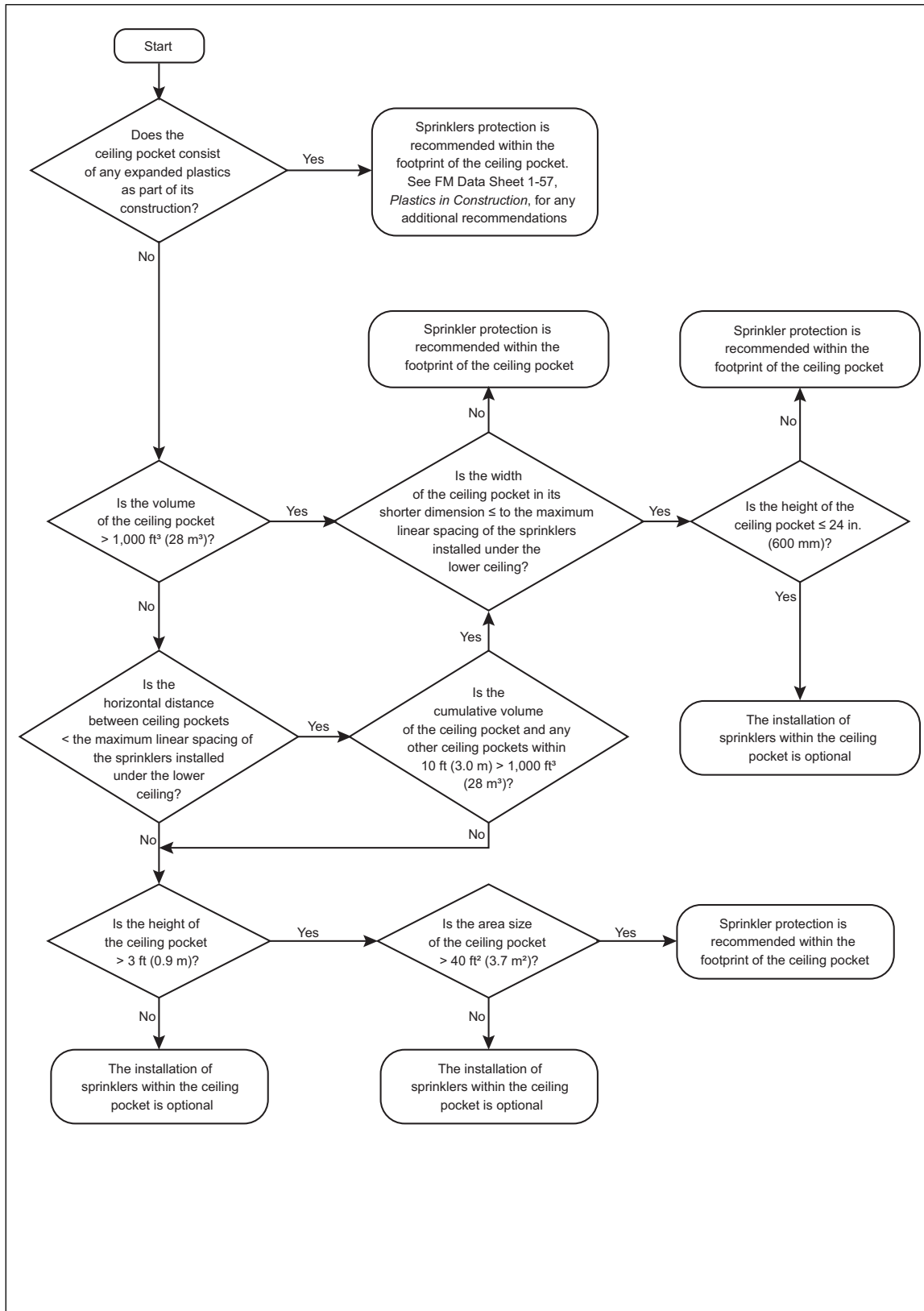

Fig. 2.5.2.1.8. Flowchart to determine if sprinklers are needed within a ceiling pocket of a non-storage area protected by pendent or upright sprinklers

### 2.5.2.1.9 Airflow Velocities Below Nonstorage Ceiling Sprinklers

2.5.2.1.9.1 For nonstorage-type occupancies, arrange any airflow between the protected occupancy and the horizontal plane located at the ceiling-level sprinklers (such as airflow from HVLS fans demonstrated in Figure 2.5.2.1.9.1(a), or HVAC equipment demonstrated in Figure 2.5.2.1.9.1(b)) so the airflow velocity does not exceed 5 ft/sec (1.5 m/sec). If the airflow cannot be limited to a maximum velocity of 5 ft/sec (1.5 m/sec) for occupancy hazards greater than HC-1, implement one of the following acceptable options:

- (1) Arrange the airflow source to shutdown automatically upon activation of the ceiling sprinkler waterflow alarm, or
- (2) If the ceiling sprinkler system will be wet or a similar system type, design the sprinkler system as if it were a dry sprinkler system. If a dry sprinkler system design is not provided from the occupancy-specific data sheet, increase the indicated wet sprinkler system design area by 30%. If the ceiling sprinkler system will be dry or a similar system type, increase the indicated design area for the dry system design by 30%, or
- (3) Install FM Approved flame detection at ceiling level that will monitor a 10 ft (3.0 m) radius of any area where airflow velocities will be greater than 5 ft/sec (1.5 m/sec). Arrange the airflow source to automatically shut down upon activation of the detection system, or
- (4) Install additional ceiling-level sprinklers in combination with a flat, continuous false ceiling as indicated in Figure 2.5.2.1.9.1(b).

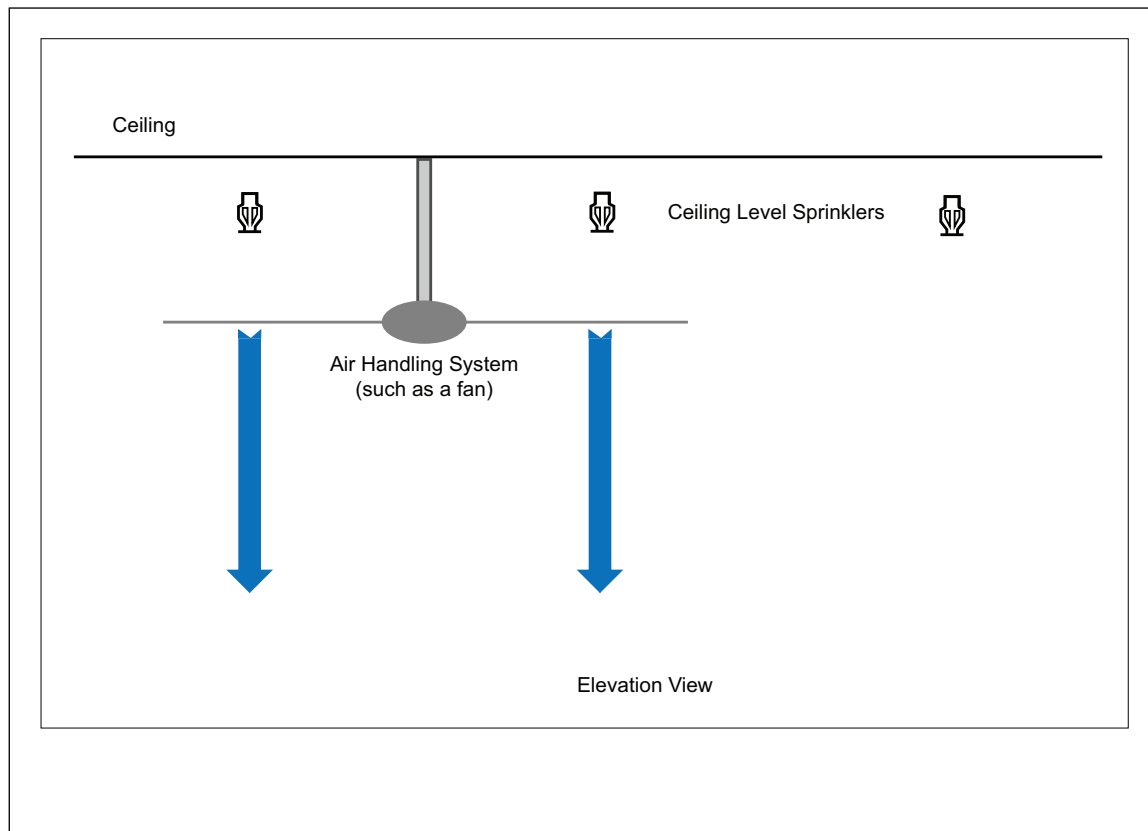

Fig. 2.5.2.1.9.1(a). Example of airflow velocities created by ceiling-mounted equipment such as HVLS type fans

2.5.2.1.9.2 Where a flat, continuous false ceiling is to be installed as shown in Figure 2.5.2.1.9.1(b), use minimum 22-gauge (0.7 mm) sheet metal or similar noncombustible material for the false ceiling; and secure it so that it can resist a minimum uplift velocity pressure of 3 lb/ft<sup>2</sup> (14.6 kg/m<sup>2</sup>). A less desirable but acceptable alternative to noncombustible materials would include minimum 3/8 in. (10 mm) plywood (or similar material).

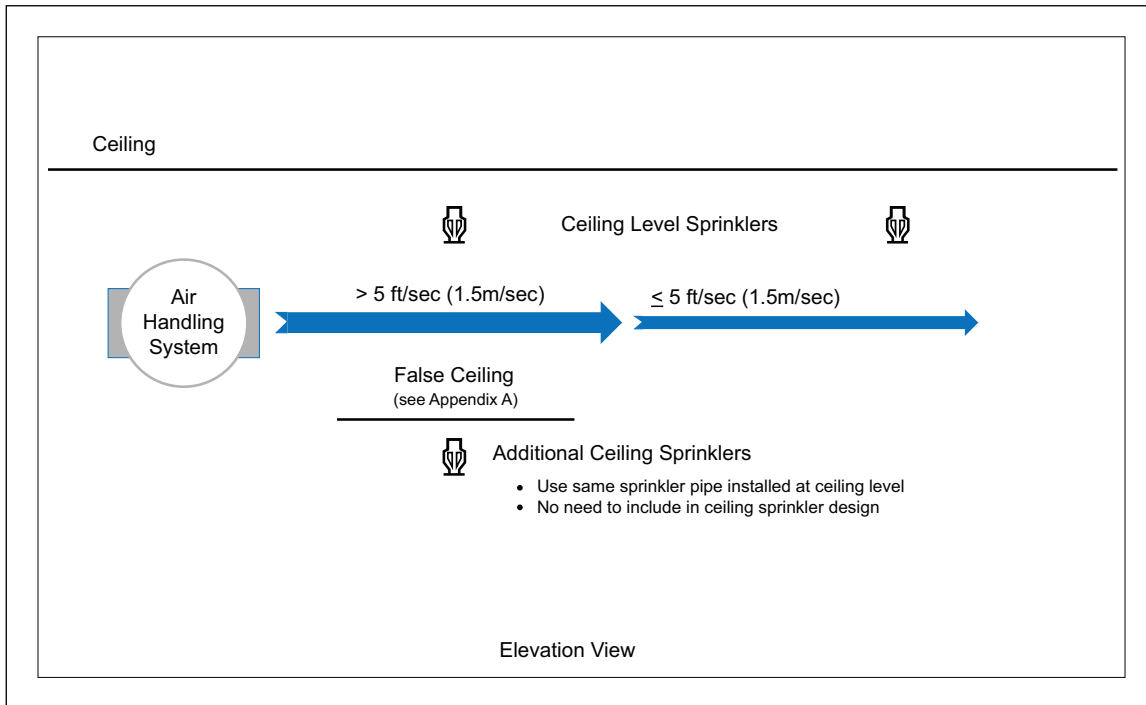

Fig. 2.5.2.1.9.1(b). Acceptable arrangement of additional ceiling-level sprinklers in areas where airflow velocities exceed 5 ft/sec (1.5 m/sec) over a nonstorage-type occupancy.

## 2.5.2.2 Determining Obstructed or Unobstructed Ceiling Construction

2.5.2.2.1 See the flowchart in Figure 2.5.2.2.1 to determine if the ceiling construction qualifies as either unobstructed or obstructed for the installation of Nonstorage pendent and upright sprinklers. Note that a solid ceiling structural member is one where its cross-sectional area in a vertical plane is less than 70% open.

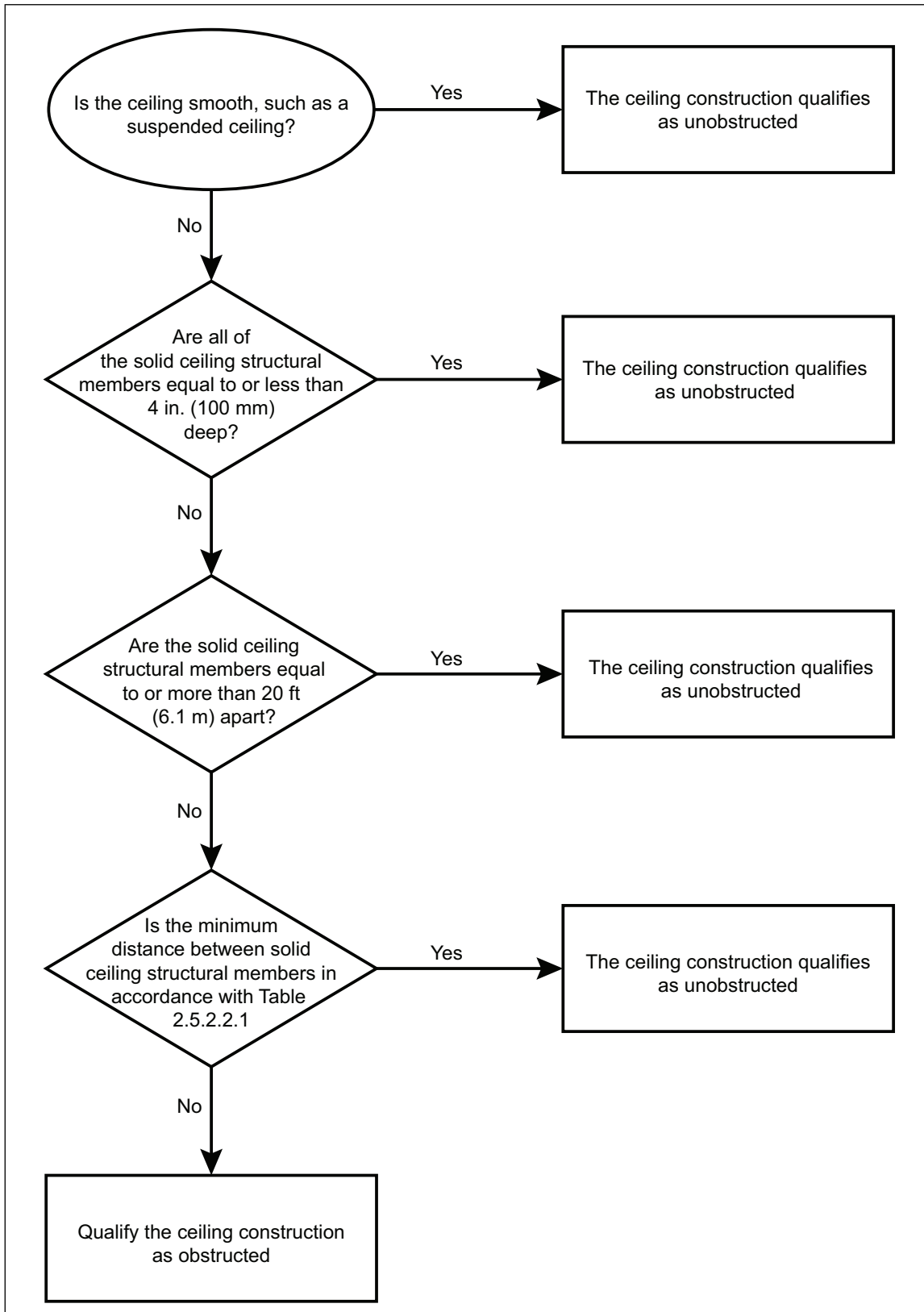

Fig. 2.5.2.2.1. Flowchart for determining ceiling construction type for Nonstorage pendent and upright sprinklers

Table 2.5.2.2.1. Determining Ceiling Construction Type When Solid Structural Members Deeper than 4 in. (100 mm) are Present

Ceiling Sprinkler K-factor Value	Maximum Occupancy Hazard Category	Maximum Ceiling Height, ft (m)	Minimum Distance Required Between Solid Ceiling Structural Members to Qualify as Unobstructed, ft (m)
≤ K8.0 (K115)	HC-2	60 (18.3)	15 (4.6)
	HC-3	30 (9.1)	12 (3.7)
		45 (13.7)	10 (3.0)
K11.2 (K160)	HC-2	60 (18.3)	15 (4.6)
	HC-3	30 (9.1)	12 (3.7)
		60 (18.3)	10 (3.0)
≥ K14 (K200)	HC-2	60 (18.3)	15 (4.6)
	HC-2	> 60 (18.3)	12 (3.7)
	HC-3	30 (9.1)	12 (3.7)
	HC-3	> 30 (9.1)	10 (3.0)
K11.2EC (K160EC) Upright	HC-1	30 (9.1)	20 (6.1)
	HC-2	60 (18.3)	16 (4.9)
	HC-3	45 (13.7)	16 (4.9)
K14.0EC (K200EC) Upright	HC-2	60 (18.3)	20 (6.1)
	HC-3	30 (9.1)	20 (6.1)
		45 (13.7)	16 (4.9)
K25.2EC (K360EC)	HC-3	Any	14 (4.3)

2.5.2.2.2 Install Nonstorage pendent and upright sprinklers in accordance with the horizontal and vertical positioning recommendations indicated in Section 2.5.2.3 if the flowchart in Figure 2.5.2.2.1 qualifies the ceiling construction type as unobstructed.

2.5.2.2.3 Install Nonstorage pendent and upright sprinklers in accordance with the horizontal and vertical positioning recommendations indicated in Section 2.5.2.4 if the flowchart in Figure 2.5.2.2.1 qualifies the ceiling construction type as obstructed.

### 2.5.2.3 Horizontal and Vertical Positioning of Nonstorage Pendent and Upright Sprinklers Under Unobstructed Ceiling Construction

#### 2.5.2.3.1 Horizontal Linear and Area Spacing of Nonstorage Pendent and Upright Sprinklers

2.5.2.3.1.1 If the occupancy-specific data sheet does not provide recommendations regarding the ceiling sprinkler spacing, install Nonstorage pendent and upright sprinklers under unobstructed ceiling construction in accordance with:

- A. Table 2.5.2.3.1.1(a) for a Hazard Category 1
- B. Table 2.5.2.3.1.1(b) for a Hazard Category 2
- C. Table 2.5.2.3.1.1(c) for a Hazard Category 3

Table 2.5.2.3.1.1(a). Spacing of Ceiling-Level Nonstorage Pendent and Upright Sprinklers for Hazard Category No. 1 Under Unobstructed Ceiling Construction

Ceiling Height, ft (m)	K-Factor	Orientation	RTI Response	Ceiling Construction Type	Maximum Ceiling Slope	Linear Spacing, ft (m)		Area Spacing, ft <sup>2</sup> (m <sup>2</sup> )	
						Min.	Max.	Min.	Max.
Up to 30 (9.1)	≥ 5.6 (80)	Pendent or Upright	Quick or Standard	Unobstructed	DNA	7 (2.1)	15 (4.6)	64 (6.0)	225 (20.9) <sup>1</sup>
	5.6EC (80EC), 8.0EC (115EC)	Pendent or Upright	Quick	Smooth, Flat	2 in 12 (10°)	10 (3.0)	20 (6.1)	100 (9.3)	400 (37.2)
	11.2EC (160EC), 14.0EC (200EC)	Pendent	Quick	Smooth, Flat	2 in 12 (10°)	10 (3.0)	20 (6.1)	100 (9.3)	400 (37.2)
	11.2EC (160EC), 14.0EC (200EC)	Upright	Quick	Unobstructed	2 in 12 (10°)	10 (3.0)	20 (6.1)	100 (9.3)	400 (37.2)
	25.2EC (360EC)	Pendent or Upright	Quick	Unobstructed	DNA	10 (3.0)	14 (4.3)	100 (9.3)	196 (18.2)
Over 30 (9.1) and up to 60 (18.3)	≥ 5.6 (80)	Pendent or Upright	Quick or Standard	Unobstructed	4 in 12 (18.5°)	7 (2.1)	15 (4.6)	64 (6.0)	130 (12.1)
	11.2EC (160EC)	Upright	Quick	Unobstructed	2 in 12 (10°)	10 (3.0)	16 (4.9)	100 (9.3)	256 (23.8)
	14.0EC (200EC)	Upright	Quick	Unobstructed	2 in 12 (10°)	10 (3.0)	20 (6.1)	100 (9.3)	400 (37.2)
	25.2EC (360EC)	Pendent or Upright	Quick	Unobstructed	4 in 12 (18.5°)	10 (3.0)	14 (4.3)	100 (9.3)	196 (18.2)
Over 60 (18.3)	≥ 14.0 (200)	Pendent or Upright	Quick	Unobstructed	4 in 12 (18.5°)	8 (2.4)	12 (3.7)	64 (6.0)	120 (11.1)
	25.2EC (360EC)	Pendent or Upright	Quick	Unobstructed	4 in 12 (18.5°)	10 (3.0)	14 (4.3)	100 (9.3)	196 (18.2)

Note 1. The maximum allowable area spacing is reduced to 130 ft<sup>2</sup> (12.1 m<sup>2</sup>) if there are combustible exposed vertical structural members spaced less than 3 ft (0.9 m) on centers

Table 2.5.2.3.1.1(b). Spacing of Ceiling-Level Nonstorage Pendent and Upright Sprinklers for Hazard Category No. 2 Under Unobstructed Ceiling Construction

Ceiling Height, ft (m)	K-Factor	Orientation	RTI Response	Ceiling Construction Type	Maximum Ceiling Slope	Linear Spacing, ft (m)		Area Spacing, ft <sup>2</sup> (m <sup>2</sup> )	
						Min.	Max.	Min.	Max.
Up to 30 (9.1)	≥ 5.6 (80)	Pendent or Upright	Quick or Standard	Unobstructed	4 in 12 (18.5°)	7 (2.1)	15 (4.6)	64 (6.0)	130 (12.1)
	11.2EC (160EC)	Pendent	Quick	Smooth, Flat	2 in 12 (10°)	10 (3.0)	16 (4.9)	100 (9.3)	256 (23.8)
	14.0EC (200EC)	Pendent	Quick	Smooth, Flat	2 in 12 (10°)	10 (3.0)	20 (6.1)	100 (9.3)	400 (37.2)
	11.2EC (160EC)	Upright	Quick	Unobstructed	2 in 12 (10°)	10 (3.0)	16 (4.9)	100 (9.3)	256 (23.8)
	14.0EC (200EC)	Upright	Quick	Unobstructed	2 in 12 (10°)	10 (3.0)	20 (6.1)	100 (9.3)	400 (37.2)
	25.2EC (360EC)	Pendent or Upright	Quick	Unobstructed	4 in 12 (18.5°)	10 (3.0)	14 (4.3)	100 (9.3)	196 (18.2)
Over 30 (9.1) and up to 60 (18.3)	≥ 5.6 (80)	Pendent or Upright	Quick or Standard	Unobstructed	4 in 12 (18.5°)	7 (2.1)	15 (4.6)	64 (6.0)	130 (12.1)
	11.2EC (160EC)	Upright	Quick	Unobstructed	2 in 12 (10°)	10 (3.0)	16 (4.9)	100 (9.3)	256 (23.8)
	14.0EC (200EC)	Upright	Quick	Unobstructed	2 in 12 (10°)	10 (3.0)	20 (6.1)	100 (9.3)	400 (37.2)
	25.2EC (360EC)	Pendent or Upright	Quick	Unobstructed	4 in 12 (18.5°)	10 (3.0)	14 (4.3)	100 (9.3)	196 (18.2)
Over 60 (18.3)	≥ 14.0 (200)	Pendent or Upright	Quick	Unobstructed	4 in 12 (18.5°)	8 (2.4)	10 (3.0)	64 (6.0)	100 (9.3)
	25.2EC (360EC)	Pendent or Upright	Quick	Unobstructed	4 in 12 (18.5°)	10 (3.0)	14 (4.3)	100 (9.3)	196 (18.2)

Table 2.5.2.3.1.1(c). Spacing of Ceiling-Level Nonstorage Pendent and Upright Sprinklers for Hazard Category No. 3 Under Unobstructed Ceiling Construction

Ceiling Height, ft (m)	K-Factor	Orientation	RTI Response	Maximum Ceiling Slope	Linear Spacing, ft (m)		Area Spacing, ft <sup>2</sup> (m <sup>2</sup> )	
					Min.	Max.	Min.	Max.
Up to 30 (9.1)	≥ 5.6 (80)	Pendent or Upright	Quick or Standard	4 in 12 (18.5°)	7 (2.1)	12 (3.7) <sup>1</sup>	64 (6.0)	100 (9.3)
	11.2EC (160EC)	Upright	Quick	2 in 12 (10°)	10 (3.0)	16 (4.9)	100 (9.3)	256 (23.8)
	14.0EC (200EC)	Upright	Quick	2 in 12 (10°)	10 (3.0)	20 (6.1)	100 (9.3)	400 (37.2)
	25.2EC (360EC)	Pendent or Upright	Quick	4 in 12 (18.5°)	10 (3.0)	14 (4.3)	100 (9.3)	196 (18.2)
Over 30 (9.1) and up to 45 (13.7)	≥ 5.6 (80)	Pendent or Upright	Quick or Standard	4 in 12 (18.5°)	7 (2.1)	10 (3.0)	64 (6.0)	100 (9.3)
	11.2EC (160EC), 14.0EC (200EC)	Upright	Quick	2 in 12 (10°)	10 (3.0)	16 (4.9)	100 (9.3)	256 (23.8)
	25.2EC (360EC)	Pendent or Upright	Quick	4 in 12 (18.5°)	10 (3.0)	14 (4.3)	100 (9.3)	196 (18.2)
Over 45 (13.7) and up to 60 (18.3)	≥ 11.2 (160)	Pendent or Upright	Quick or Standard	4 in 12 (18.5°)	8 (2.4)	10 (3.0)	64 (6.0)	100 (9.3)
	25.2EC (360EC)	Pendent or Upright	Quick	4 in 12 (18.5°)	10 (3.0)	14 (4.3)	100 (9.3)	196 (18.2)
Over 60 (18.3)	≥ 14.0 (200)	Pendent or Upright	Quick	4 in 12 (18.5°)	8 (2.4)	10 (3.0)	64 (6.0)	100 (9.3)
	25.2EC (360EC)	Pendent or Upright	Quick	4 in 12 (18.5°)	10 (3.0)	14 (4.3)	100 (9.3)	196 (18.2)

Note 1. The maximum allowable linear spacing can be increased to 12.5 ft (3.8 m) if the ceiling structural members create bays up to 25 ft (7.6 m) wide.

2.5.2.3.1.2 Measure the linear distance between sprinklers along the slope of the ceiling, not on the viewpoint from floor level.

### 2.5.2.3.2 Horizontal Distance from Walls and Corners to Nonstorage Sprinklers

Install Nonstorage pendent and upright sprinklers horizontally from walls, measured perpendicular to the wall, and wall corners as shown in Figure 2.5.2.3.2.

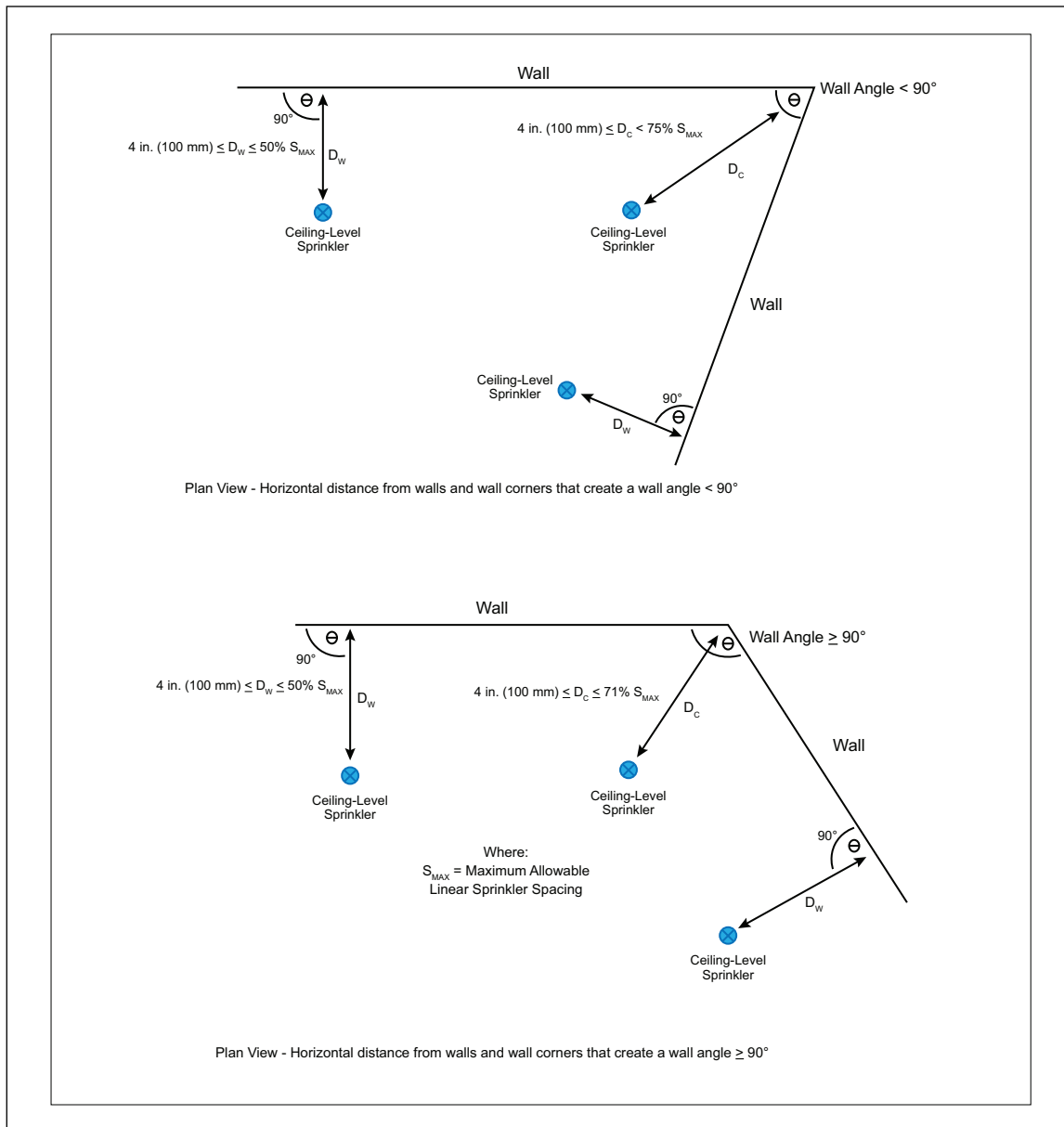

Fig. 2.5.2.3.2. Horizontal distances from walls and wall corners to Nonstorage pendent and upright sprinklers

### 2.5.2.3.3 Vertical Location of Nonstorage Sprinklers Under Unobstructed Construction

2.5.2.3.3.1 The vertical distance between a sprinkler (centerline of the sprinkler's thermal element) and the underside of the ceiling is measured perpendicular to the ceiling as shown in Figure 2.5.2.3.3.1.

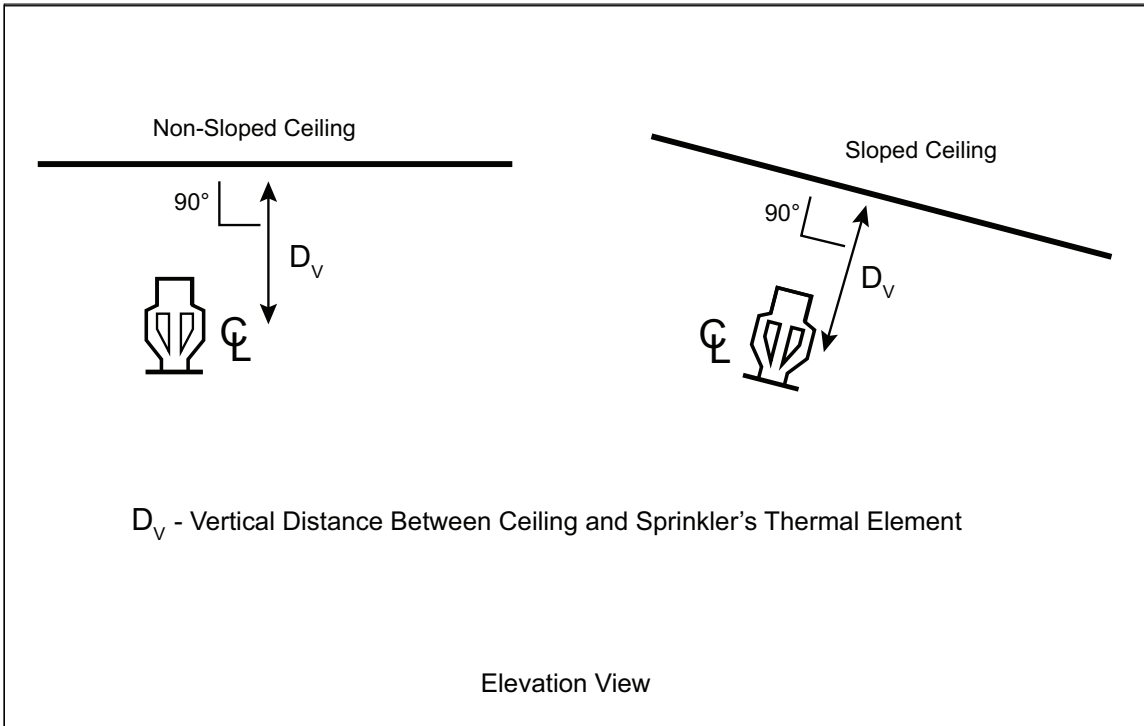

Fig. 2.5.2.3.3.1. Measuring vertical distance between a Nonstorage sprinkler's thermal element and the underside of the ceiling

2.5.2.3.3.2 If a ceiling is corrugated, see Figure 2.5.2.3.3.2 to determine how to measure the vertical distance from the sprinkler's thermal element to the underside of the ceiling.

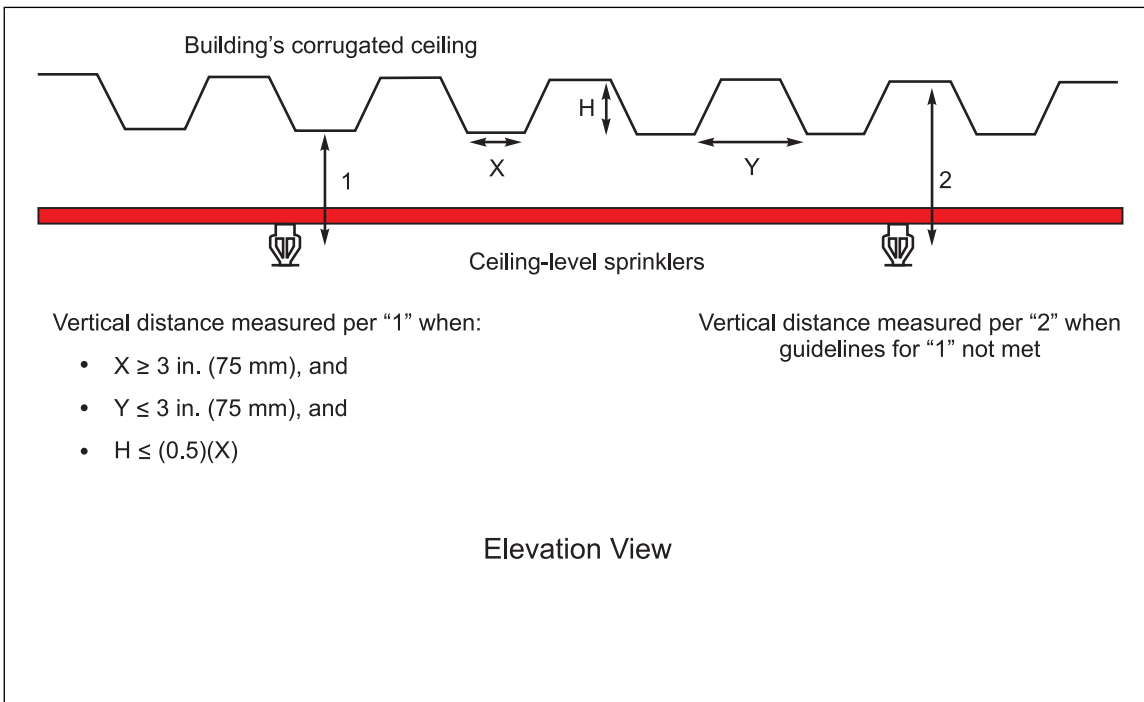

Fig. 2.5.2.3.3.2. How to measure the vertical distance between the thermal element of Nonstorage pendent and upright sprinklers and the underside of a corrugated ceiling

2.5.2.3.3.3 If a vinyl-type canvas support, or similar type of insulating system (a reflective ceiling does not apply), is provided below the underside of the ceiling, the vertical distance between the sprinkler (centerline of the sprinkler's thermal element) and the ceiling is measured as shown in Figure 2.5.2.3.3.3.

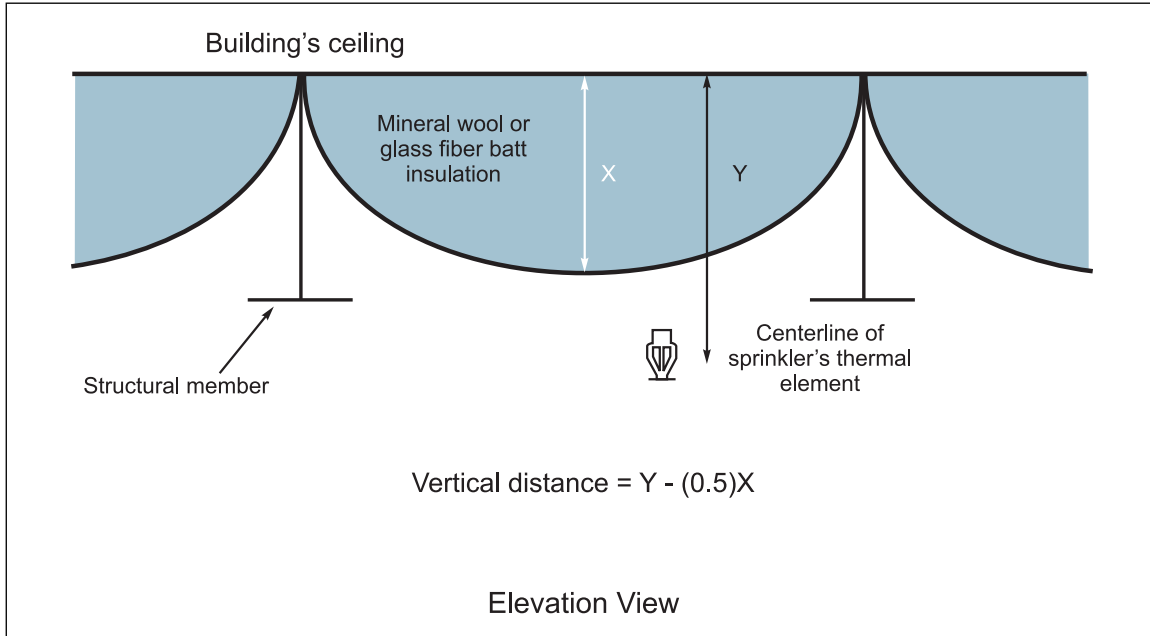

Fig. 2.5.2.3.3.3. Vertical distance between ceiling and centerline of sprinkler's thermal element in the presence of mineral wool or glass fiber batt insulation

2.5.2.3.3.4 Unless indicated otherwise by the relevant occupancy-specific data sheet, install the centerline of Nonstorage pendent and upright sprinklers thermal elements vertically below the underside of the ceiling as shown in Figure 2.5.2.3.3.4. See Table 2.5.2.3.1.1(a), Table 2.5.2.3.1.1(b), and Table 2.5.2.3.1.1(c) to determine which sprinklers are allowed for the indicated ceiling height.

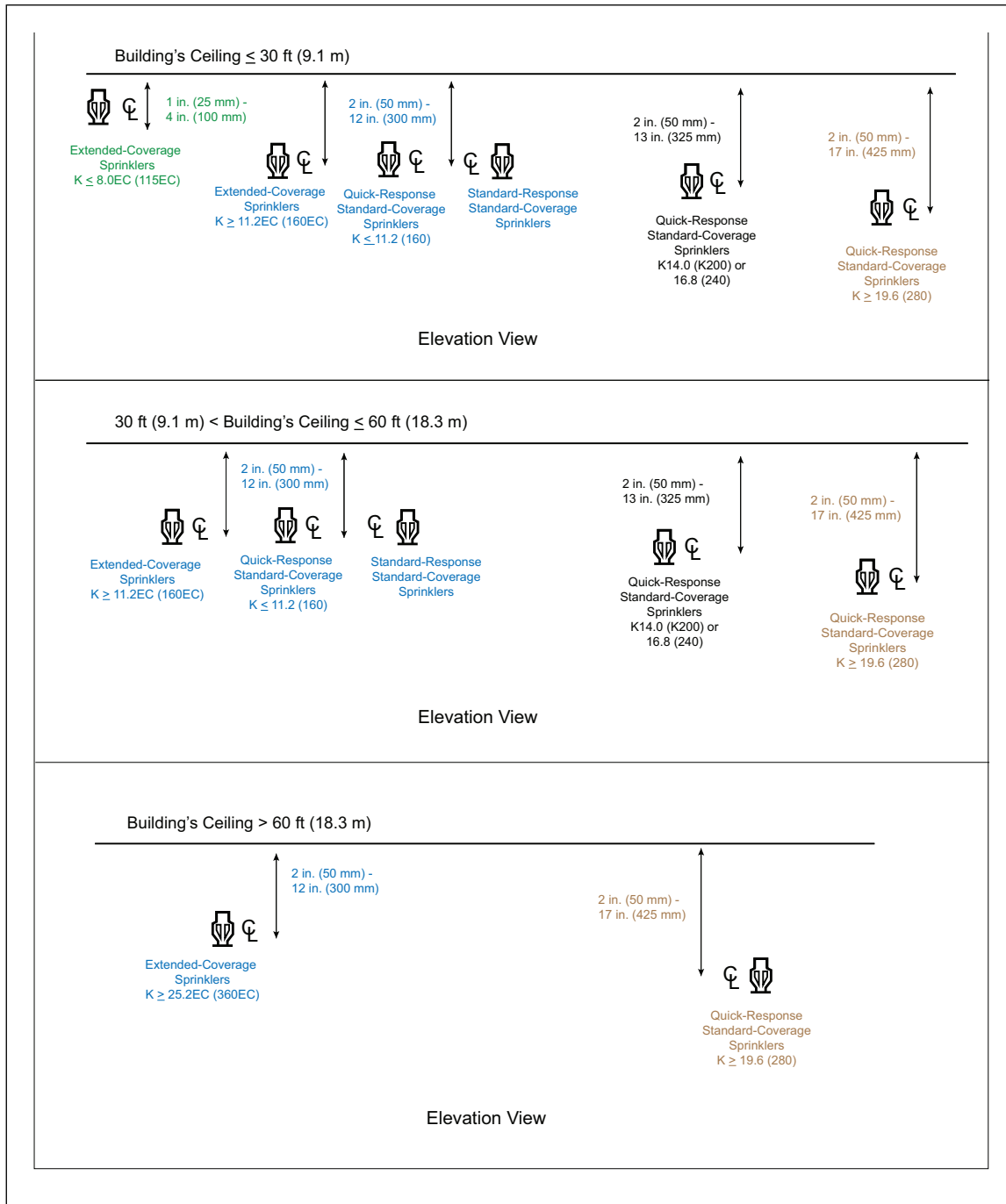

Fig. 2.5.2.3.3.4. Vertical location of Nonstorage pendent and upright sprinklers under unobstructed ceiling construction for various ceiling heights

2.5.2.3.3.5 The requirements of Section 2.5.2.3.3.4 do not apply to flush, recessed or concealed Nonstorage sprinklers.

### 2.5.2.3.4 Impact of Ceiling Slope on Installation of Nonstorage Pendent and Upright Sprinklers

2.5.2.3.4.1 See the flowchart in Figure 2.5.2.3.4.1(a) for guidelines involving the impact of ceiling slope in the presence of Nonstorage sprinklers. For ceilings that are not straight, base the ceiling slope using a tangent line at the point of the ceiling being analyzed (point of tangency).

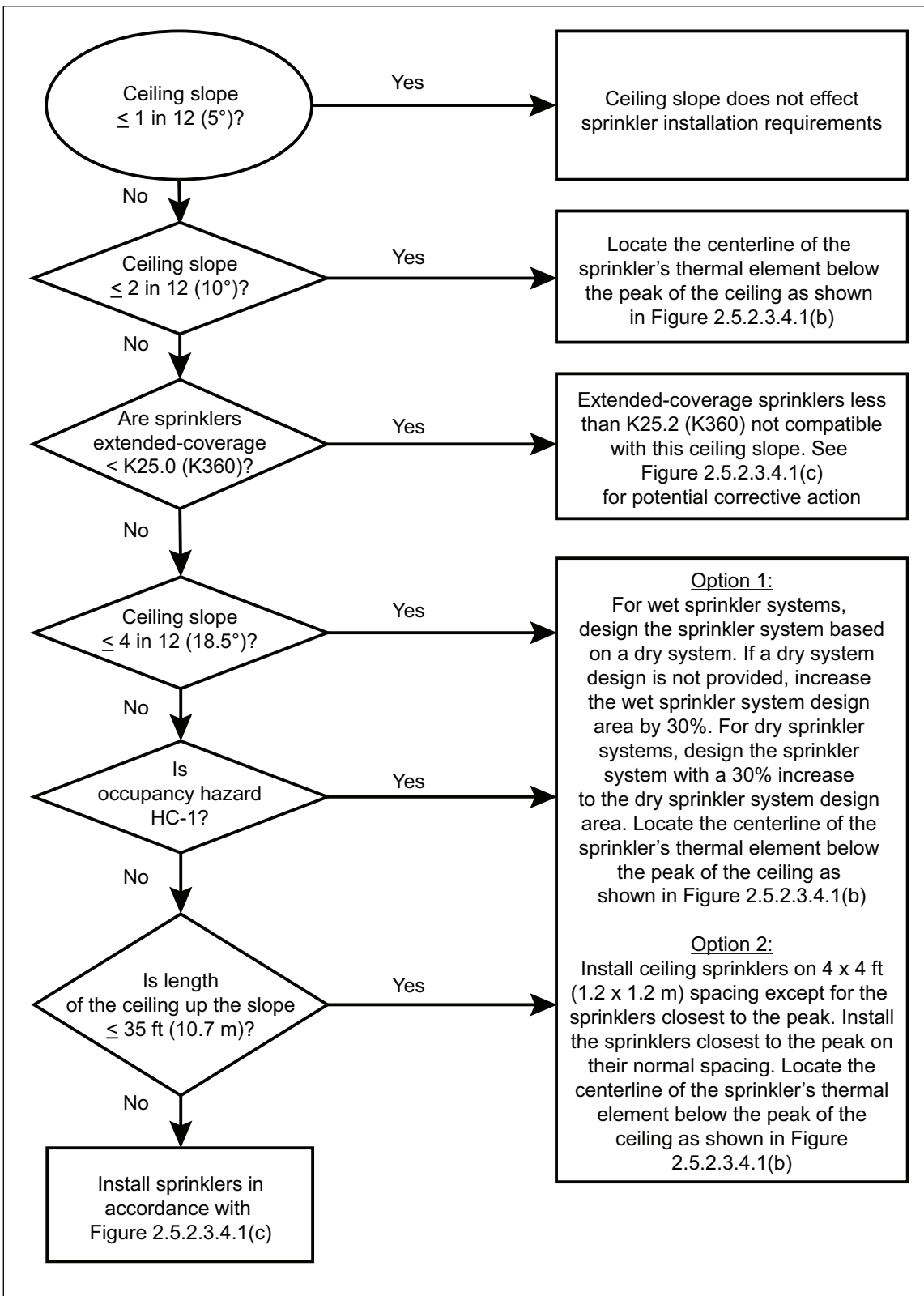

Fig. 2.5.2.3.4.1(a). Guidelines involving ceiling slope with Nonstorage sprinklers

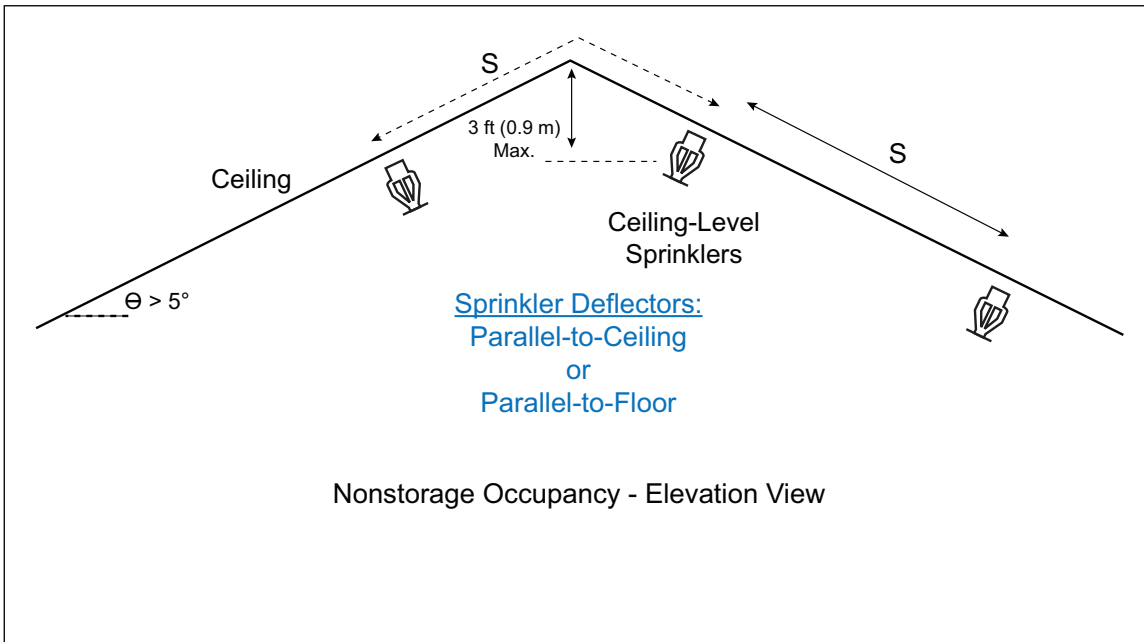

Fig. 2.5.2.3.4.1(b). Location of Nonstorage pendent and upright sprinklers near ceiling peak when slope exceeds 1 in 12 (5°)

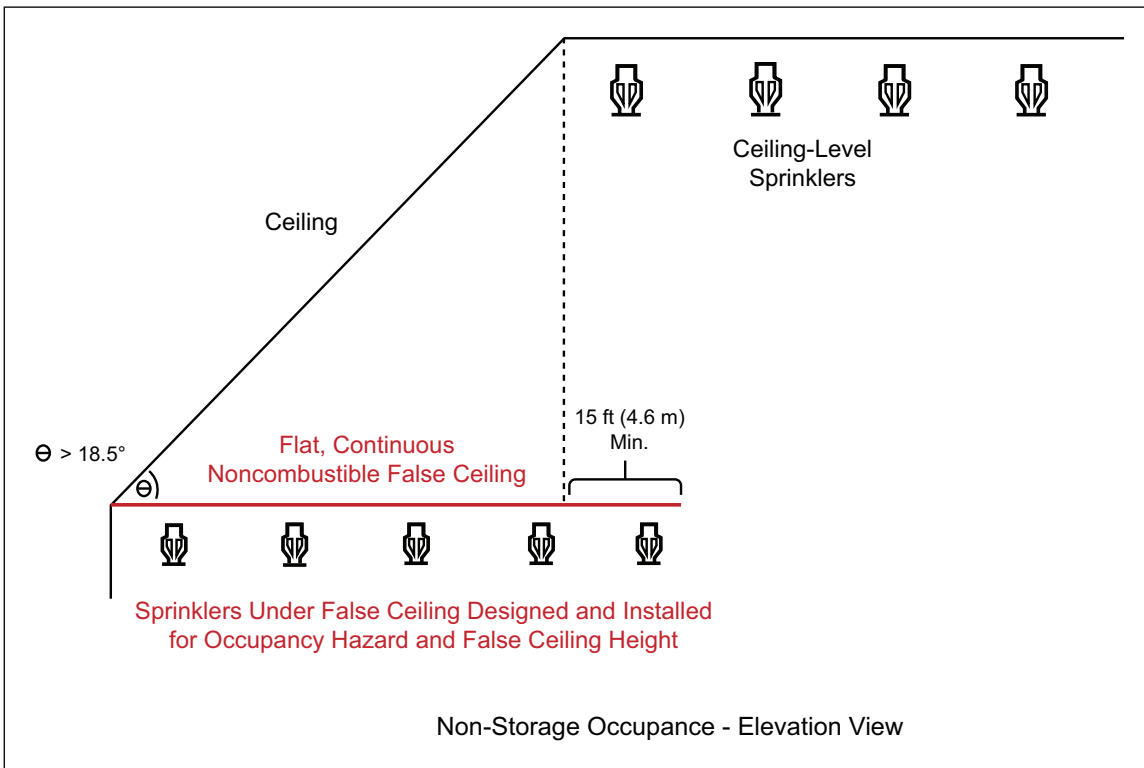

Fig. 2.5.2.3.4.1(c). Recommended sprinkler installation per Figure 2.5.2.3.4.1(a) when ceiling slope exceeds 4 in 12 (18.5°)

2.5.2.3.4.2 Where a flat, continuous false ceiling is to be installed as shown in Figure 2.5.2.3.4.1(c), use minimum 22-gauge (0.7 mm) sheet metal or similar noncombustible material for the false ceiling; and secure it so that it can resist a minimum uplift velocity pressure of 3 lb/ft<sup>2</sup> (14.6 kg/m<sup>2</sup>). A less desirable but acceptable alternative to noncombustible materials would include minimum 3/8 in. (10 mm) plywood (or similar material).

2.5.2.3.4.3 Install Nonstorage pendent and upright sprinklers so their deflector is either parallel to the ceiling or parallel to the floor.

### **2.5.2.4 Horizontal and Vertical Positioning of Nonstorage Pendent and Upright Sprinklers Under Obstructed Ceiling Construction**

2.5.2.4.1 Measure the linear distance between sprinklers along the slope of the ceiling, not on the viewpoint from floor level.

2.5.2.4.2 See the flowchart in Figure 2.5.2.4.2 to determine the recommended horizontal and vertical location of the ceiling sprinklers.

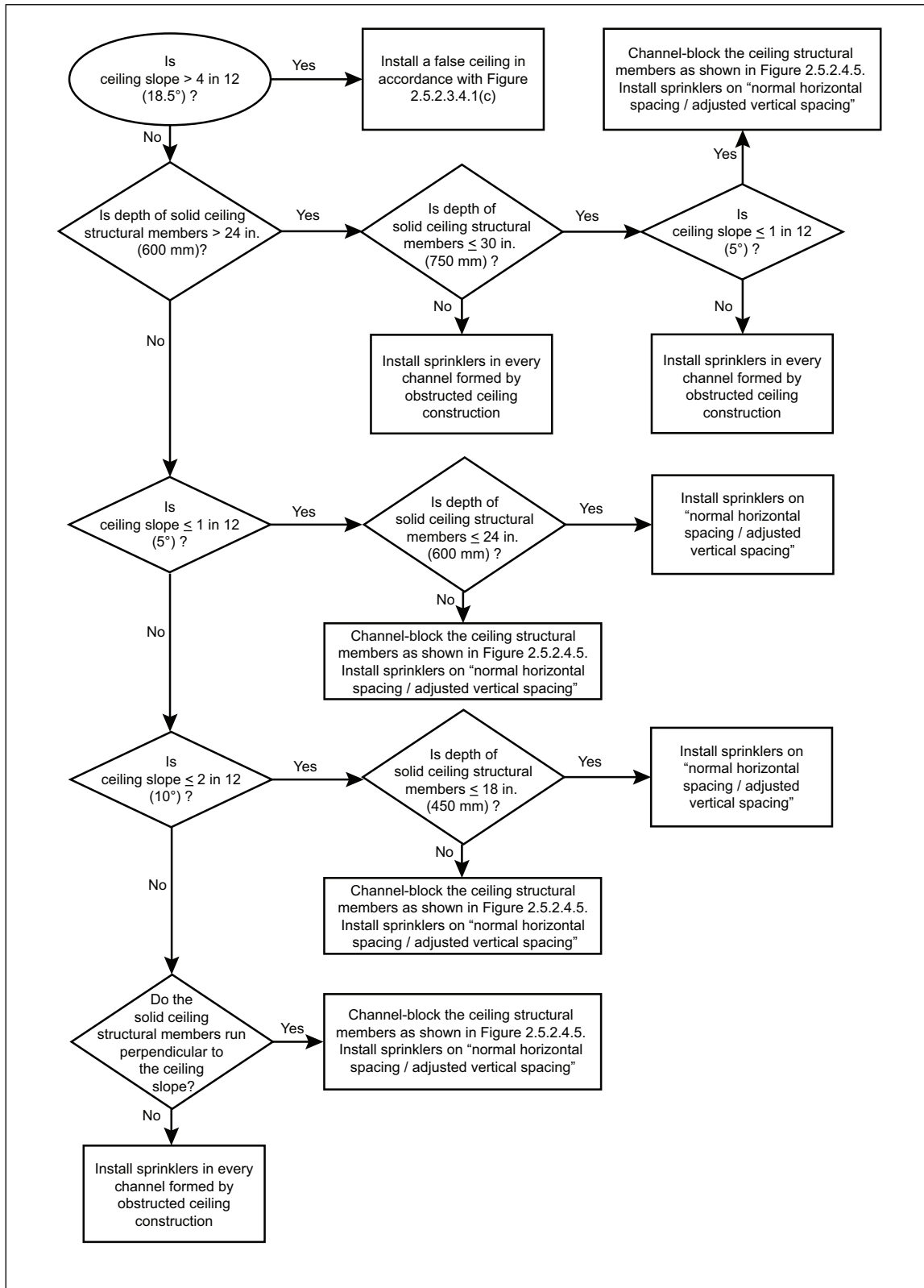

Fig. 2.5.2.4.2. Determining the horizontal and vertical location of Nonstorage pendent and upright sprinklers in the presence of obstructed ceiling construction

2.5.2.4.3 If the flowchart in Figure 2.5.2.4.2 indicates to install sprinklers in every channel formed by obstructed ceiling construction:

A. Horizontal spacing: Determine the minimum and maximum allowable horizontal spacing of the sprinklers within each channel based on the linear spacings indicated in the occupancy-specific data sheet. If spacing is not provided, then use those indicated in either Table 2.5.2.3.1.1(a), Table 2.5.2.3.1.1(b), or Table 2.5.2.3.1.1(c) for the applicable hazard category. If the ceiling structural members have openings, stagger sprinklers horizontally between channels, as needed, to meet the minimum recommended linear spacing requirements.

B. Vertical spacing: Determine the minimum and maximum allowable vertical location of the sprinklers below the ceiling within each channel based on the distances indicated in Section 2.5.2.3.3.

C. Sprinkler system design: If sprinklers are installed in every channel formed by obstructed ceiling construction and the ceiling sprinkler system design is based on density / demand area, use the following steps for establishing the demand area and the design flow at the most remote sprinkler:

1. If not specified by the occupancy-specific data sheet, the number of sprinklers operating per branch line is determined by taking the square root of the demand area, multiplying it by the applicable shape factor and then dividing it by the linear spacing of the sprinklers being installed within the channel created by the ceiling structural members. Use normal rounding methods if this calculation does not result in a whole number.
2. The number of sprinklers to include in the hydraulic analysis of the ceiling sprinkler system is determined by taking the indicated required demand area and dividing it by the maximum allowable area spacing of the ceiling sprinkler being installed. Use normal rounding methods if this calculation does not result in a whole number.
3. The minimum required flow at the most remote ceiling sprinkler is determined by taking the indicated required density and multiplying it by the maximum allowable area spacing of the ceiling sprinkler being installed.

2.5.2.4.4 If the flowchart in Figure 2.5.2.4.2 indicates to install sprinklers on normal horizontal spacing /adjusted vertical spacing, install the sprinklers below the underside of the ceiling structural members as follows:

A. Horizontal spacing: Determine the minimum and maximum allowable horizontal spacing of the sprinklers based on the linear and area spacings indicated in the occupancy-specific data sheet. If spacing is not provided, use those indicated in either Table 2.5.2.3.1.1(a), Table 2.5.2.3.1.1(b), or Table 2.5.2.3.1.1(c) for the applicable hazard category.

B. Vertical spacing: Determine the minimum and maximum allowable vertical location of the sprinklers below the ceiling based on the distances indicated in Section 2.5.2.3.3. However, if the depth of the solid structural members prevents the guidelines from Section 2.5.2.3.3 to be implemented, locate the thermal element of the sprinklers on a plane not exceeding 6 in. (150 mm) below the underside of the solid ceiling structural members as demonstrated in Figure 2.5.2.4.4.

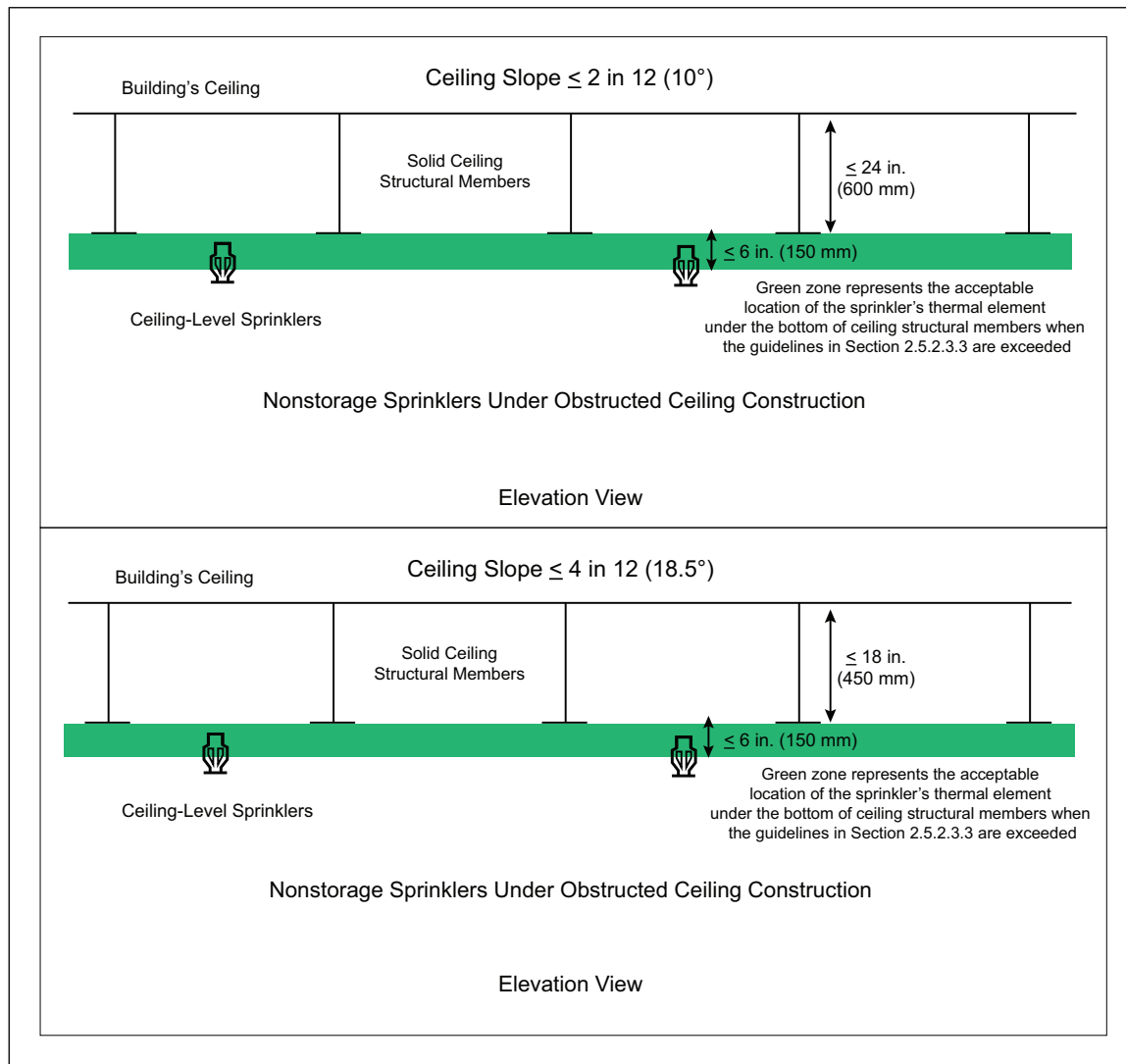

Fig. 2.5.2.4.4. Vertical location of Nonstorage pendent and upright sprinklers under obstructed ceiling construction

2.5.2.4.5 If the flowchart in Figure 2.5.2.4.2 indicates to channel-block the ceiling structural members and install sprinklers on normal horizontal spacing/adjusted vertical spacing, install the sprinklers below the underside of the ceiling structural members as follows:

A. Horizontal spacing: Determine the minimum and maximum allowable horizontal spacing of the sprinklers based on the linear and area spacings indicated in the occupancy-specific data sheet. If spacing is not provided, then use those indicated in either Table 2.5.2.3.1.1(a), Table 2.5.2.3.1.1(b), or Table 2.5.2.3.1.1(c) for the applicable hazard category.

B. Vertical spacing: Determine the minimum and maximum allowable vertical location of the sprinklers below the ceiling based on the distances indicated in Section 2.5.2.3.3. However, if the depth of the solid structural members prevents the guidelines from Section 2.5.2.3.3 from being implemented, locate the thermal element of the sprinklers on a plane not exceeding 6 in. (150 mm) below the underside of the solid ceiling structural members as demonstrated in Figure 2.5.2.4.4.

C. Channel-block the entire depth of the channels created by the solid ceiling structural members, as demonstrated in Figure 2.5.2.4.5, limiting each channel to a maximum volume of:

1. 400 ft<sup>3</sup> (11.3 m<sup>3</sup>) for ceiling slopes ≤ 2 in 12 (10°), or
2. 300 ft<sup>3</sup> (8.5 m<sup>3</sup>) for ceiling slopes over 2 in 12 (10°) but not more than 4 in 12 (18.5°).

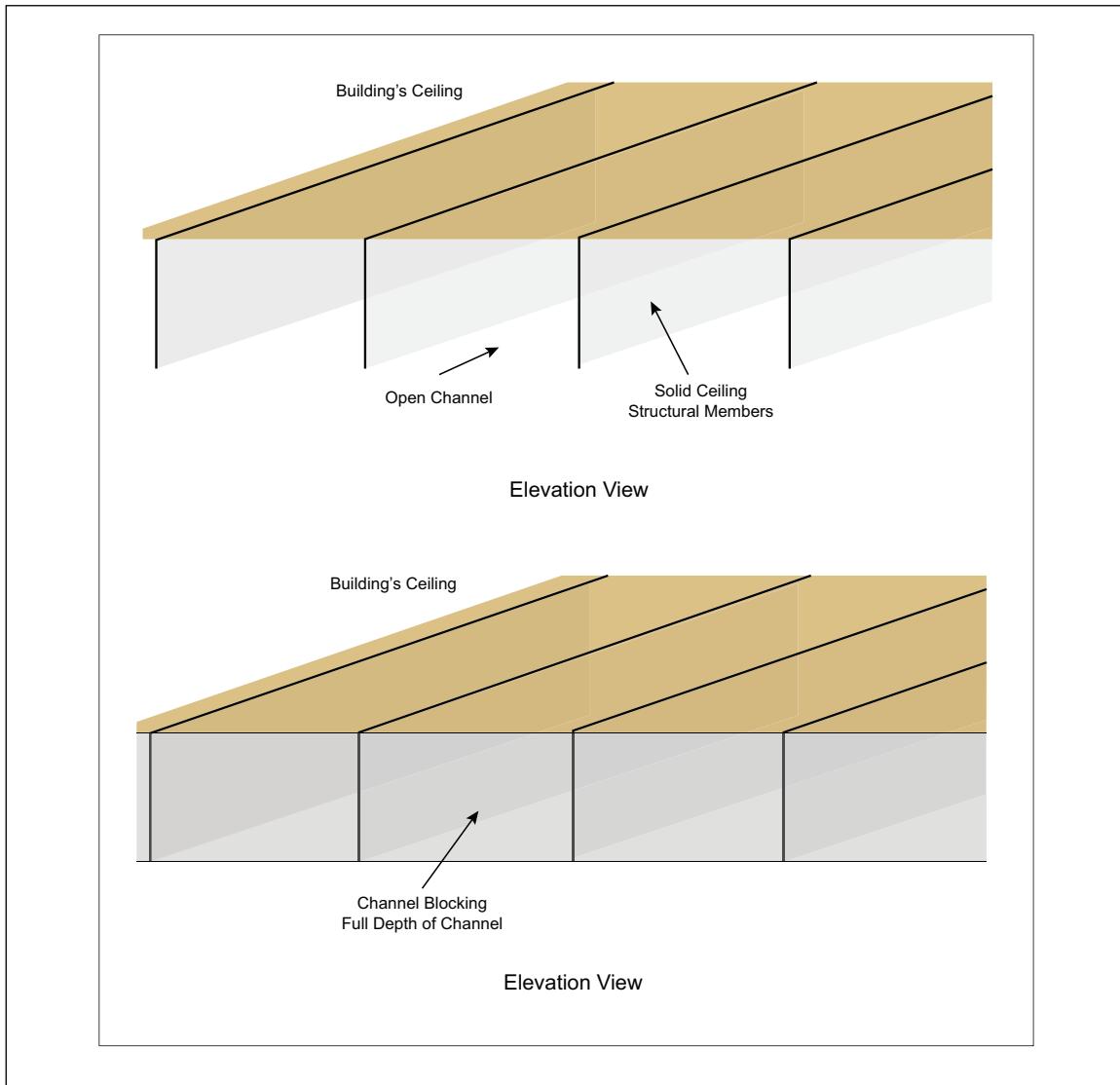

Fig. 2.5.2.4.5. Channel-blocking each channel created by obstructed ceiling construction

When channel-blocking the entire depth of the channel formed by obstructed construction, open gaps up to 4 in. (100 mm) tall between the underside of the ceiling and the top of the ceiling structural members (such as those created by a corrugated steel deck roof) do not need to be filled.

2.5.2.4.6 Install Nonstorage pendent and upright sprinklers horizontally from walls, measured perpendicular to the wall, and wall corners as shown in Figure 2.5.2.3.2.

2.5.2.4.7 If the ceiling slope exceeds a pitch of 1 in 12 (5°), locate the sprinklers within 3 ft (0.9 m) of the ceiling peak as shown in Figure 2.5.2.3.4.1(b).

2.5.2.4.8 Install Nonstorage pendent and upright sprinklers so their deflector is either parallel to the ceiling or parallel to the floor.

### 2.5.2.5 Obstruction to the Discharge Pattern of Ceiling-Level Nonstorage Pendent and Upright Sprinklers

#### 2.5.2.5.1 General Recommendations for Obstructions to Ceiling-Level Nonstorage Pendent and Upright Sprinklers

2.5.2.5.1.1 Any object located entirely within the checkerboard area of Figure 2.5.2.5.1.1(a) for standard-coverage sprinklers or Figure 2.5.2.5.1.1(b) for extended-coverage sprinklers does not qualify as an obstruction to the sprinkler's discharge pattern.

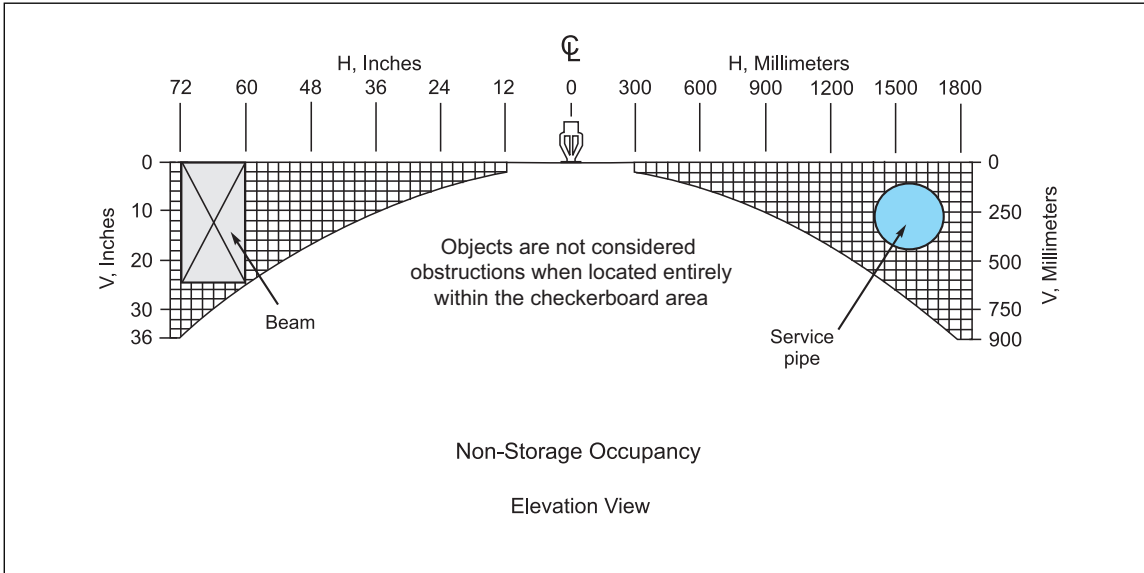

Fig. 2.5.2.5.1.1(a). Objects near ceiling level not considered obstructions to standard-coverage Nonstorage pendent and upright sprinklers

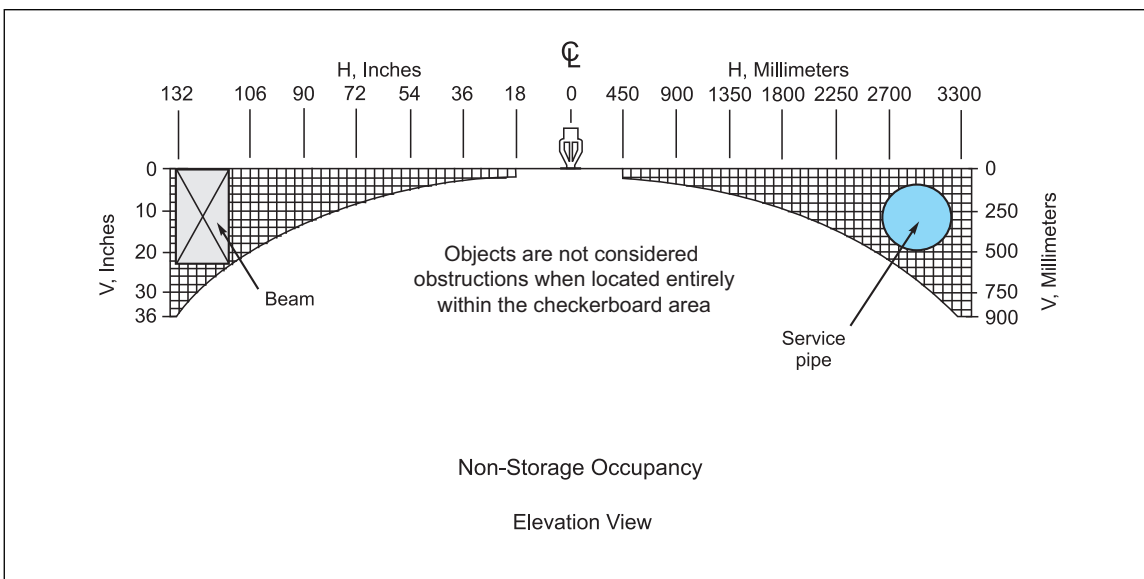

Fig. 2.5.2.5.1.1(b). Objects near ceiling level not considered obstructions to extended-coverage Nonstorage pendent and upright sprinklers

2.5.2.5.1.2 If an object is not located entirely within the checkerboard, see the following sections to determine whether the object qualifies as an unacceptable obstruction to the sprinkler's discharge pattern.

### 2.5.2.5.2 Ceiling Structural Members and Other Similar Objects Located Near Ceiling-Level Nonstorage Pendent and Upright Sprinklers

2.5.2.5.2.1 If ceiling structural members or other similar objects less than 70% open in their vertical profile extend down out of the checkerboard pattern, as demonstrated in Figure 2.5.2.5.2.1(a), position sprinklers on either side of the ceiling structural member as shown in Figure 2.5.2.5.2.1(b).

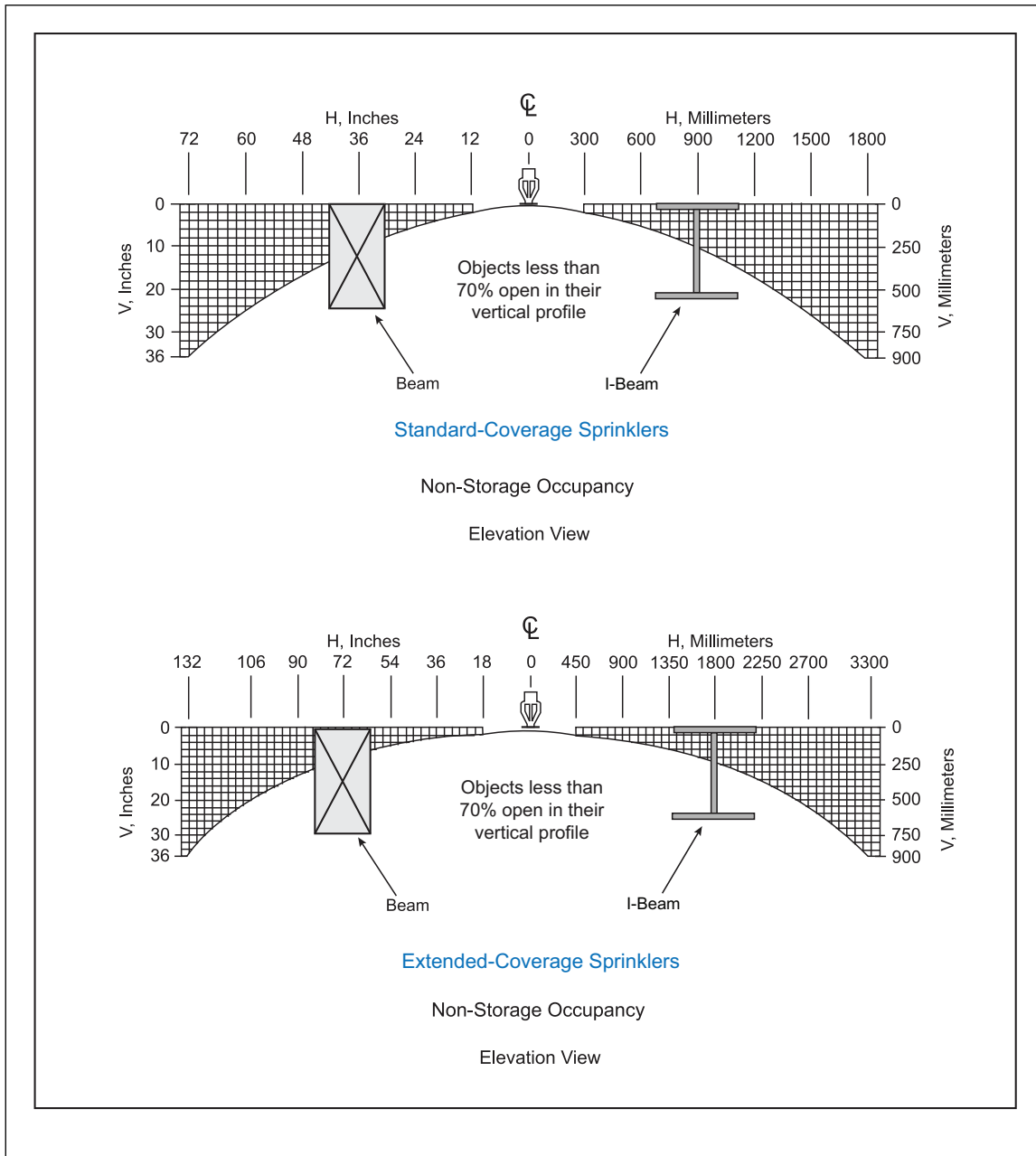

Fig. 2.5.2.5.2.1(a). Example of ceiling structural members that obstruct sprinkler discharge pattern

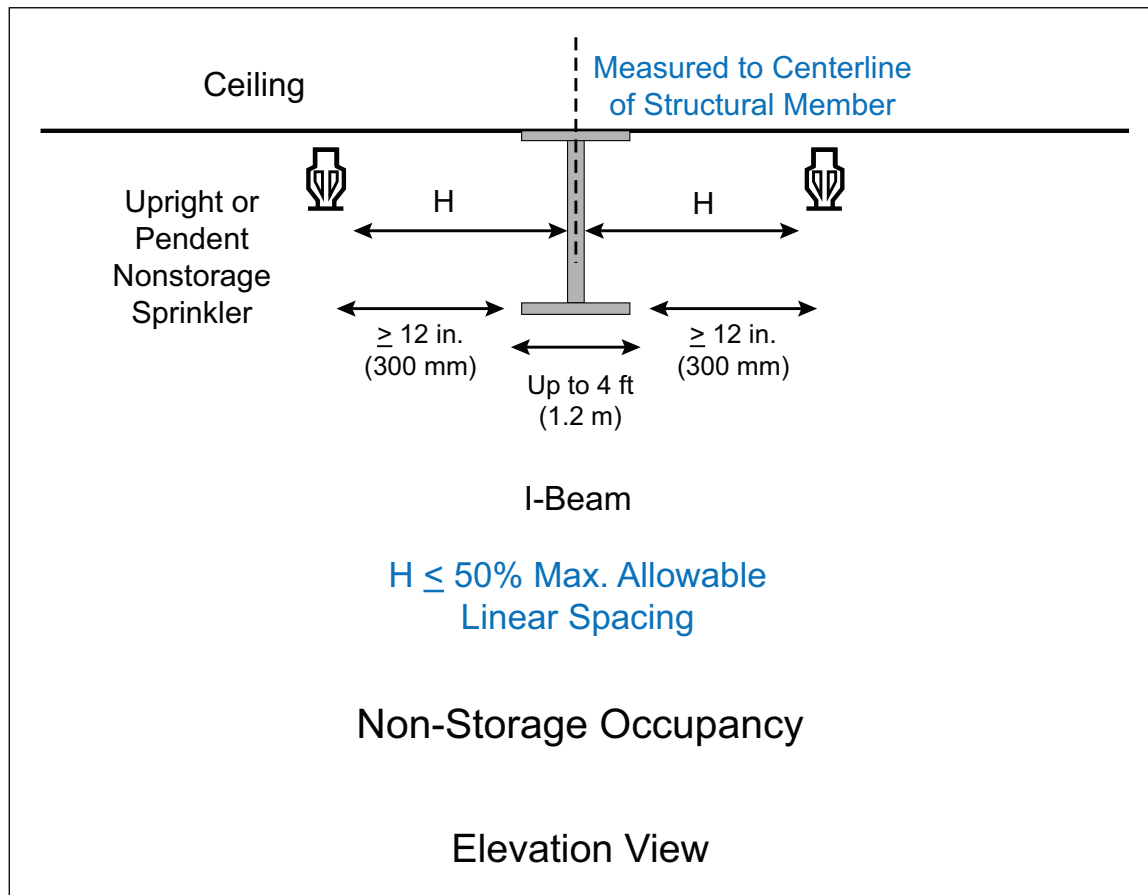

Fig. 2.5.2.5.2.1(b). Positioning ceiling-level sprinklers when ceiling structural members obstruct sprinkler discharge

2.5.2.5.2.2 Ceiling structural members or other similar objects that are 70% or more open in their vertical profile do not qualify as obstructions to the sprinkler's discharge pattern.

2.5.2.5.2.3 If ceiling structural members or other similar objects are a minimum of 70% open in their vertical profile, but are located less than 12 in. (300 mm) horizontally away from standard-coverage sprinklers, or less than 18 in. (450 mm) horizontally away from extended-coverage sprinklers, ensure that any cross-bracing or similar objects that make up the structural member are:

- A. No wider than 3 in. (75 mm), and
- B. Located a minimum horizontal distance of three times the width of the object from the sprinkler.

2.5.2.5.2.4 If the guidelines of Section 2.5.2.5.2.3 cannot be met, reposition a standard-coverage sprinkler so that it is a minimum of 12 in. (300 mm) horizontally from the nearest ceiling structural member, or 18 in. (450 mm) horizontally away from the nearest structural member if the sprinkler is extended-coverage.

### 2.5.2.5.3 Individual or Grouped Objects Located Below Ceiling-Level Nonstorage Pendent and Upright Sprinklers

2.5.2.5.3.1 An object can be considered an "individual object" for the purpose of analyzing it as a potential obstruction to ceiling sprinkler discharge if it is located a minimum of 3 times its width from an adjacent object that is either the same size or larger. See Figure 2.5.2.5.3.1 for an example of applying this guidance.

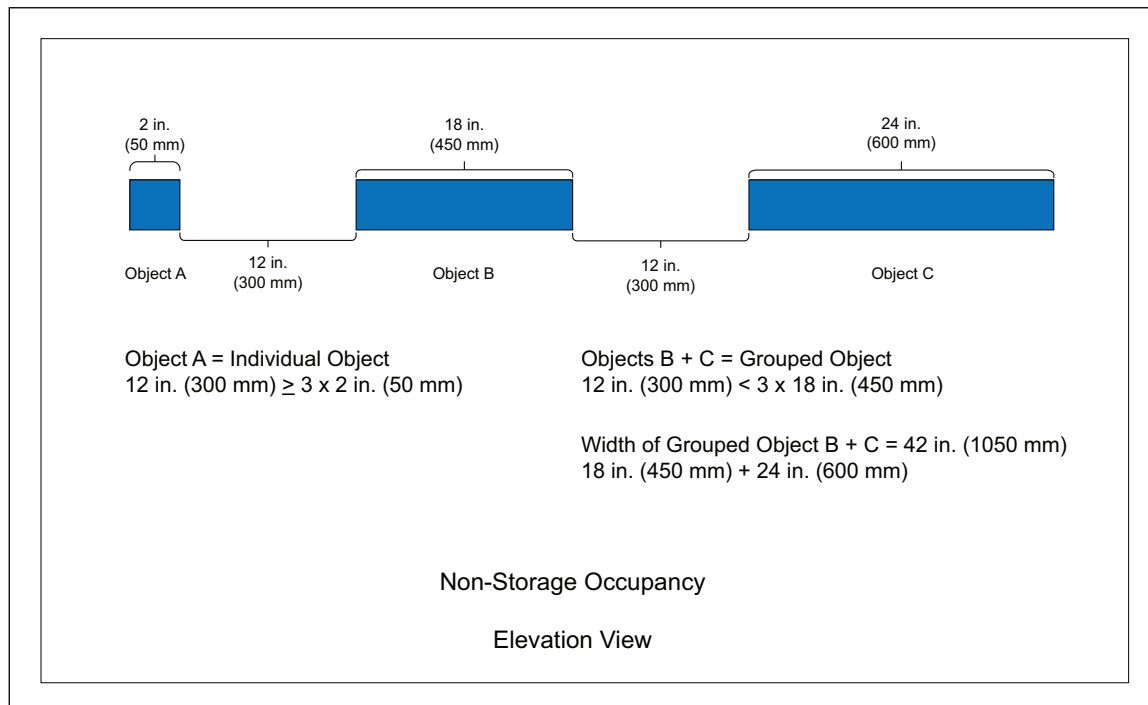

Fig. 2.5.2.5.3.1. Example of an "Individual Object" and a "Grouped Object" for analyzing obstructions

2.5.2.5.3.2 Group an object with an adjacent object of the same size or larger if the horizontal distance between the two objects is less than 3 times the width of the smaller object. See Figure 2.5.2.5.3.1 for an example of applying this guidance.

2.5.2.5.3.3 If two or more objects are considered a "grouped object", their overall width is the collective sum of each of the objects that make-up the grouped object; the open spaces between them do not need to be included in the calculation as demonstrated in Figure 2.5.2.5.3.1.

#### 2.5.2.5.4 Objects Up to 4 ft (1.2 m) Wide Located Below the Ceiling-Level Nonstorage Pendent and Upright Sprinklers

Any object up to 4 ft (1.2 m) wide, as measured in the object's least dimension and in a plane that is parallel to the floor, does not qualify as an obstruction to the sprinkler's discharge pattern.

#### 2.5.2.5.5 Objects Over 4 ft (1.2 m) Wide Located Below the Ceiling-Level Nonstorage Pendent and Upright Sprinklers

2.5.2.5.5.1 For individual or grouped objects over 4 ft (1.2 m) wide, design and install supplemental sprinklers under the obstructing object in accordance with Sections 2.5.2.5.5.2 through 2.5.2.5.5.4.

2.5.2.5.5.2 The design for the supplemental sprinklers is considered acceptable and does not need to be hydraulically balanced or accounted for in the ceiling sprinkler design when all the following conditions are met:

- A. The supplemental sprinklers are fed from a wet (or similar) sprinkler system, and
- B. The pipe size feeding the supplemental sprinklers is equal to or larger than the branch line pipe size of the overhead ceiling sprinkler system, and
- C. The supplemental sprinklers will have the same attributes (characteristics) as the ceiling sprinklers. Acceptable attribute differences include (1) the supplemental sprinklers are quick-response if the ceiling sprinklers are standard-response, or (2) the K-factor of the supplemental sprinklers is greater than the K-factor of the ceiling sprinklers or (3) the nominal temperature rating of the supplemental sprinklers is lower than the nominal temperature rating of the ceiling sprinklers.

2.5.2.5.5.3 Where the guidelines of Section 2.5.2.5.5.2 are not met, the design for the supplemental sprinklers, for the purpose of sizing the pipe feeding them, is determined as follows:

- A. Obtain the recommended density from the occupancy-specific data sheet for the occupancy hazard located below the obstruction by using the bottom of the obstruction, under which the supplemental sprinklers will be installed, as the “ceiling height” for design purposes, and
- B. Include all the supplemental sprinklers for the affected area, up to a maximum of four, in the design area. If more than one branch line will feed the supplemental sprinklers, the four sprinklers in the design can be accounted for using two sprinklers on two lines, and
- C. The required flow and pressure for the supplemental sprinkler design does not need to be hydraulically balanced with the overhead ceiling sprinkler system.

2.5.2.5.5.4 Install the supplemental sprinklers as follows:

- A. Position the supplemental sprinklers on a vertical plane as close to the underside of the obstructing object as possible.
- B. Install the supplemental sprinklers horizontally within the footprint of the obstructing object, using the linear and area spacing guidelines indicated in either Table 2.5.2.3.1.1(a), Table 2.5.2.3.1.1(b), or Table 2.5.2.3.1.1(c), depending on (1) the occupancy hazard being protected and (2) the attributes of the supplemental sprinkler being installed.

### 2.5.2.5.6 Obstruction to Ceiling-Level Nonstorage Sprinkler Discharge Due to Open-Grid Ceilings

2.5.2.5.6.1 Do not install an open-grid ceiling (see Appendix A) unless the occupancy is classified as either a HC-1 or a HC-2 hazard category, as defined per Data Sheet 3-26, *Fire Protection Water Demand for Nonstorage Sprinklered Properties*.

2.5.2.5.6.2 If an open-grid ceiling consisting of uniform openings that constitute at least 70% of the ceiling area will be installed in the presence of either HC-1 or HC-2 occupancies, install the sprinklers located above the open-grid ceiling in accordance with Table 2.5.2.5.6.2.

Table 2.5.2.5.6.2. Spacing Guidelines for Ceiling Sprinklers Located Above the Open-Grid Ceiling in the Presence of an Open-Grid Ceiling.

Hazard Category per Data Sheet 3-26	Vertical Depth of Open-Grid Ceiling	Clearance Between Sprinkler Deflectors and Top of Open-Grid Ceiling	Maximum Allowable Linear Spacing	Maximum Allowable Area Spacing
HC-1	≤ 1/2 in. (13 mm)	≥ 18 in. (450 mm)	10 ft (3.0 m)	100 ft² (9.3 m²)
		≥ 24 in. (600 mm)	12 ft (3.7 m)	120 ft² (11.1 m²)
		≥ 48 in. (1200 mm)	Treat as if the open-grid ceiling is not present	Treat as if the open-grid ceiling is not present
	> 1/2 in. (13 mm)	≥ 48 in. (1200 mm)	Treat as if the open-grid ceiling is not present	Treat as if the open-grid ceiling is not present
HC-2	≤ 1/4 in. (7 mm)	≥ 24 in. (600 mm)	10 ft (3.0 m)	100 ft² (9.3 m²)
		≥ 36 in. (900 mm)	Treat as if the open-grid ceiling is not present	Treat as if the open-grid ceiling is not present
	> 1/4 in. (7 mm)	48 in. (1200 mm)	Treat as if the open-grid ceiling is not present	Treat as if the open-grid ceiling is not present

**2.5.2.5.7 Obstruction to Ceiling-Level Nonstorage Sprinkler Discharge Due to Open-Grid Mezzanines**

2.5.2.5.7.1 Whenever possible, avoid the installation of an open-grid mezzanine (see definition in Appendix A). Instead, provide the mezzanine level with a solid flooring and install sprinklers under the solid flooring in accordance with Section 2.5.1.4.

2.5.2.5.7.2 Sprinklers may be omitted from the underside of an open-grid mezzanine if the mezzanine level will be void of any storage, equipment or other similar objects that could obstruct ceiling sprinkler discharge to the area below the mezzanine.

2.5.2.5.7.3 If Sections 2.5.2.5.7.1 and 2.5.2.5.7.2 are not satisfied, install sprinklers under an open-grid mezzanine as follows:

- A. Sprinkler Type: 160°F (70°C) nominally rated, quick-response Nonstorage sprinklers equipped with water shields
- B. Sprinkler Spacing: Per Table 2.5.2.3.1.1(a), Table 2.5.2.3.1.1(b), or Table 2.5.2.3.1.1(c), depending on the occupancy hazard, but do not exceed a linear spacing of 13 ft (3.9 m) nor an area spacing of 130 ft<sup>2</sup> (12 m<sup>2</sup>)
- C. Sprinkler Design: For the occupancy hazard under the mezzanine as if the mezzanine was solid

2.5.2.5.7.4 If sprinklers are installed in accordance with Section 2.5.2.5.7.3, the sprinkler system under the mezzanine does not need to be hydraulically balanced with the ceiling-level sprinkler system.

**2.5.2.5.8 Obstruction to Ceiling-Level Nonstorage Sprinkler Discharge Due to Open-Grid Walkways**

2.5.2.5.8.1 Whenever possible, avoid the installation of an open-grid walkway (see definition in Appendix A). Instead, provide the walkway level with a solid flooring and install sprinklers under the solid flooring in accordance with Section 2.5.1.5.

2.5.2.5.8.2 Sprinklers may be omitted from the underside of an open-grid walkway when:

- A. The width of the walkway does not exceed 4 ft (1.2 m), or
- B. The area below the walkway will be void of combustibles, or
- C. The walkway will be a minimum of 70% open.

2.5.2.5.8.3 If Sections 2.5.2.5.8.1 and 2.5.2.5.8.2 are not satisfied, install sprinklers under an open-grid walkway as follows:

- A. Sprinkler Type: 160°F (70°C) nominally rated, quick-response Nonstorage sprinklers equipped with water shields that have the same K-factor, coverage-type, and orientation as the sprinkler being installed at ceiling level.
- B. Sprinkler Spacing: Install the sprinklers under the open-grid walkway using the same maximum spacing that will be used for the ceiling-level sprinklers, however, do not exceed a linear spacing of 13 ft (3.9 m).
- C. Sprinkler Design: Use the same branch line pipe size that is being installed at ceiling level.

2.5.2.5.8.4, If sprinklers are installed in accordance with Section 2.5.2.5.8.3, the sprinkler protection under the walkway does not need to be hydraulically balanced with the ceiling-level sprinkler system.

**2.5.2.5.9 Obstruction to Ceiling-Level Nonstorage Sprinkler Discharge Due to Conveyors.**

See the flowchart in Figure 2.5.2.5.9 to determine if the conveyor is an unacceptable obstruction to ceiling sprinkler discharge.

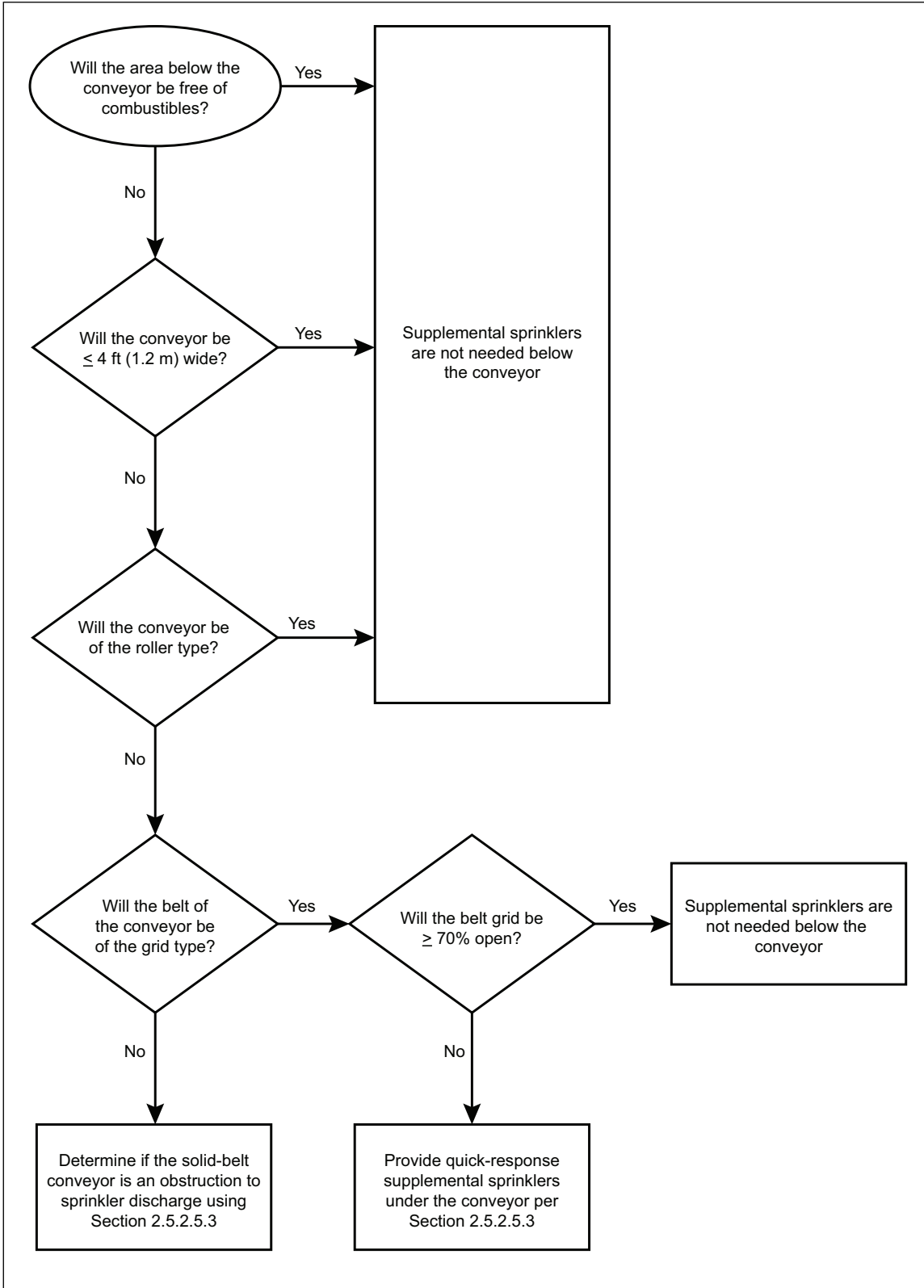

Fig. 2.5.2.5.9. Flowchart to determine if a conveyor is an obstruction to ceiling sprinkler discharge

## 2.5.3 Nonstorage Sidewall Sprinklers

### 2.5.3.1 General Recommendations for Nonstorage Sidewall Sprinklers

2.5.3.1.1 Sidewall sprinklers are acceptable for use under the following conditions:

- A. The occupancy hazard qualifies as either HC-1 or HC-2 as defined in Data Sheet 3-26, *Fire Protection for Nonstorage Occupancies*, and
- B. The ceiling construction type qualifies as flat, smooth, and unobstructed, and
- C. The ceiling height of the protected area does not exceed 30 ft (9.1 m).

2.5.3.1.2 See Section 2.5.3.4 for additional general recommendations regarding the K14.0EC (K200EC) horizontal sidewall sprinkler.

### 2.5.3.1.3 Ceiling Pockets in the Presence of Nonstorage Sidewall Sprinklers

See the flowchart in Figure 2.5.3.1.3 to determine if sprinklers are recommended within the footprint of a ceiling pocket in addition to being installed under the main lower ceiling of the protected area.

If the flowchart indicates that sprinklers are recommended within the ceiling pocket, install the sprinklers based on the guidelines indicated for the maximum ceiling height of the ceiling pocket. Note that the minimum allowable horizontal distances between sprinklers in the ceiling pocket and those located below the main ceiling can be ignored. However, the maximum allowable horizontal distances between these sprinklers cannot be ignored.

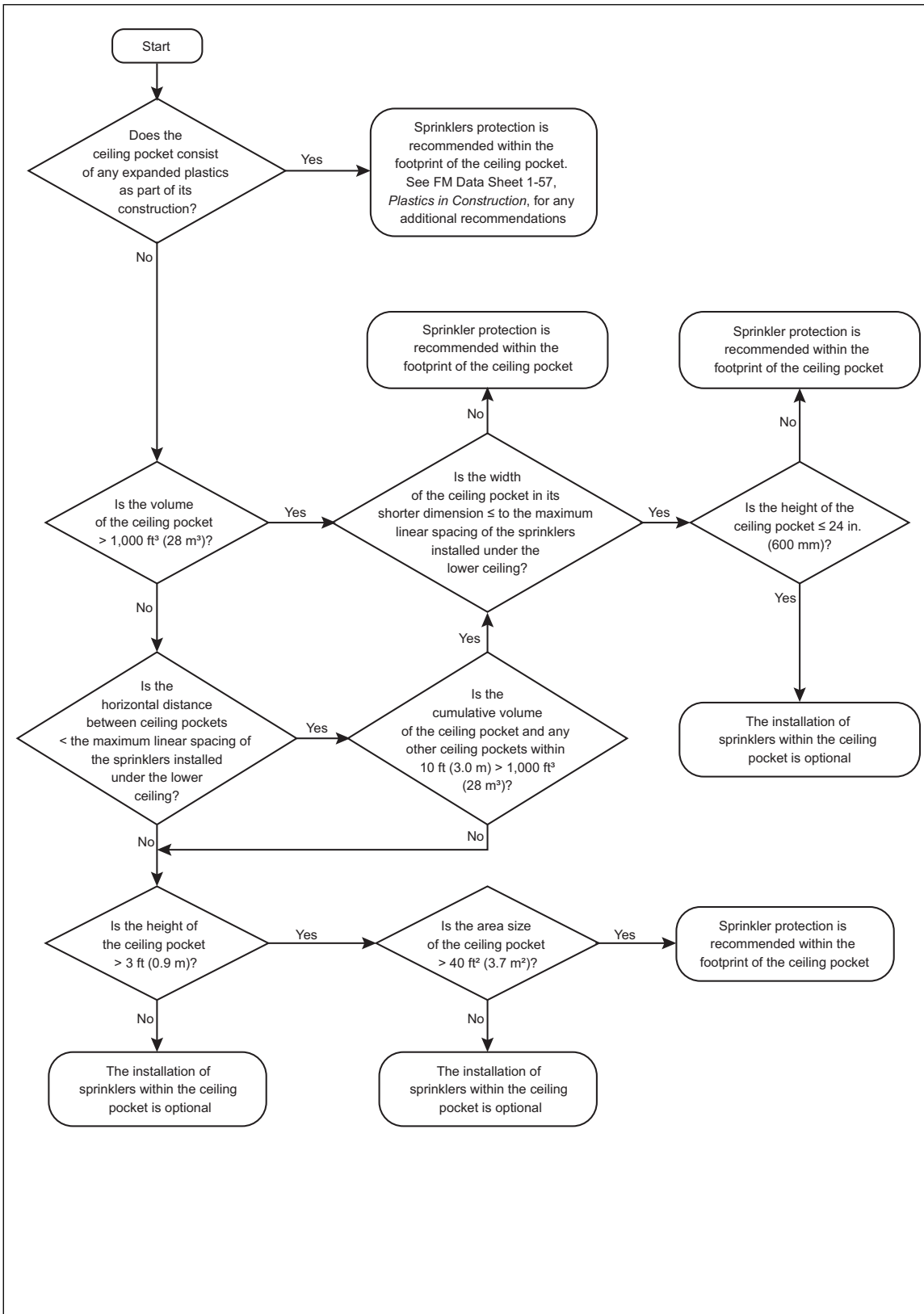

Fig. 2.5.3.1.3. Flowchart to determine if sprinklers are needed within a ceiling pocket of a non-storage area protected by sidewall sprinklers

## 2.5.3.2 Horizontal Positioning of Nonstorage Sidewall Sprinklers

### 2.5.3.2.1 Horizontal Linear Spacing of Nonstorage Sidewall Sprinklers

2.5.3.2.1.1 If the occupancy-specific data sheet does not provide recommendations regarding the ceiling sprinkler spacing, install Nonstorage sidewall sprinklers under unobstructed ceiling construction in accordance with Table 2.5.3.2.1.1(a) or Table 2.5.3.2.1.1(b), depending on the occupancy hazard category.

Table 2.5.3.2.1.1(a). Spacing of Ceiling-Level Nonstorage Sidewall Sprinklers for Hazard Category No. 1

Ceiling/Wall Type	K-Factor	RTI Rating	Linear Spacing				Area Spacing	
			Along the Mounting Wall		Away from the Mounting Wall			
			Min. ft (m)	Max., ft (m)	Min. ft (m)	Max., ft (m)	Min., ft <sup>2</sup> (m <sup>2</sup> )	Max., ft <sup>2</sup> (m <sup>2</sup> )
Flat, Smooth, with Noncombustible Finish	5.6 (80)	Quick or Standard	6 (1.8)	14 (4.3)	6 (1.8)	14 (4.3)	DNA	196 (18.2)
	5.6EC (80EC)	Quick	See Note 1	16 (4.9)	See Note 1	20 (6.1)	DNA	320 (29.7)
	8.0EC (115EC)	Quick	See Note 1	16 (4.9)	See Note 1	24 (7.3)	DNA	384 (35.7)
Flat, Smooth, with Combustible Finish	5.6 (80)	Quick or Standard	6 (1.8)	14 (4.3)	6 (1.8)	12 (3.7)	DNA	120 (11.1)
	5.6EC (80EC)	Quick	See Note 1	16 (4.9)	See Note 1	20 (6.1)	DNA	320 (29.7)
	8.0EC (115EC)	Quick	See Note 1	16 (4.9)	See Note 1	24 (7.3)	DNA	384 (35.7)

Note 1. The minimum linear spacing is that required to prevent sprinklers from being installed within the protected area of adjacent extended-coverage sidewall sprinklers

Table 2.5.3.2.1.1(b). Spacing of Ceiling-Level Nonstorage Sidewall Sprinklers for Hazard Category No. 2

Ceiling/Wall Type	K-Factor	RTI Rating	Linear Spacing				Area Spacing	
			Along the Mounting Wall		Away from the Mounting Wall			
			Min. ft (m)	Max., ft (m)	Min. ft (m)	Max., ft (m)	Min., ft <sup>2</sup> (m <sup>2</sup> )	Max., ft <sup>2</sup> (m <sup>2</sup> )
Flat, Smooth, with Noncombustible Finish	5.6 (80)	Quick or Standard	6 (1.8)	10 (3.0)	6 (1.8)	10 (3.0)	DNA	100 (9.3)
Flat, Smooth, with Combustible Finish	5.6 (80)	Quick or Standard	6 (1.8)	10 (3.0)	6 (1.8)	10 (3.0)	DNA	80 (7.4)

2.5.3.2.1.2 Measure the linear distance between sprinklers along the slope of the ceiling, not on the viewpoint from floor level.

2.5.3.2.1.3 Install Nonstorage sidewall sprinklers along a continuous wall, lintel, or similar structural object, and only under flat, smooth ceiling construction having a maximum ceiling slope of 2 in 12 (10°).

2.5.3.2.1.4 Nonstorage sidewall sprinklers can be installed along non-continuous vertical walls, such as lintels and soffits, if the following criteria is met:

- A. The non-continuous wall is tight to the ceiling above, and
- B. The wall extends vertically downward a minimum of 2 in. (50 mm) beyond the centerline of the sprinkler's thermal sensing element, and
- C. The vertical location recommendations for deflector arrangement as indicated in Section 2.5.3.3 are met.

2.5.3.2.1.5 Install Nonstorage sidewall sprinklers with their deflectors arranged parallel to the ceiling.

2.5.3.2.1.6 See Section 2.5.3.4 for horizontal linear spacing recommendations regarding the K14.0EC (K200EC) horizontal sidewall sprinkler.

### 2.5.3.2.2 Horizontal Location of Nonstorage Sidewall Sprinklers from Walls

2.5.3.2.2.1 Install Nonstorage sidewall sprinklers horizontally from walls, measured perpendicular to the wall, as shown in Figure 2.5.3.2.2.1(a), and wall corners as shown in Figure 2.5.3.2.2.1(b).

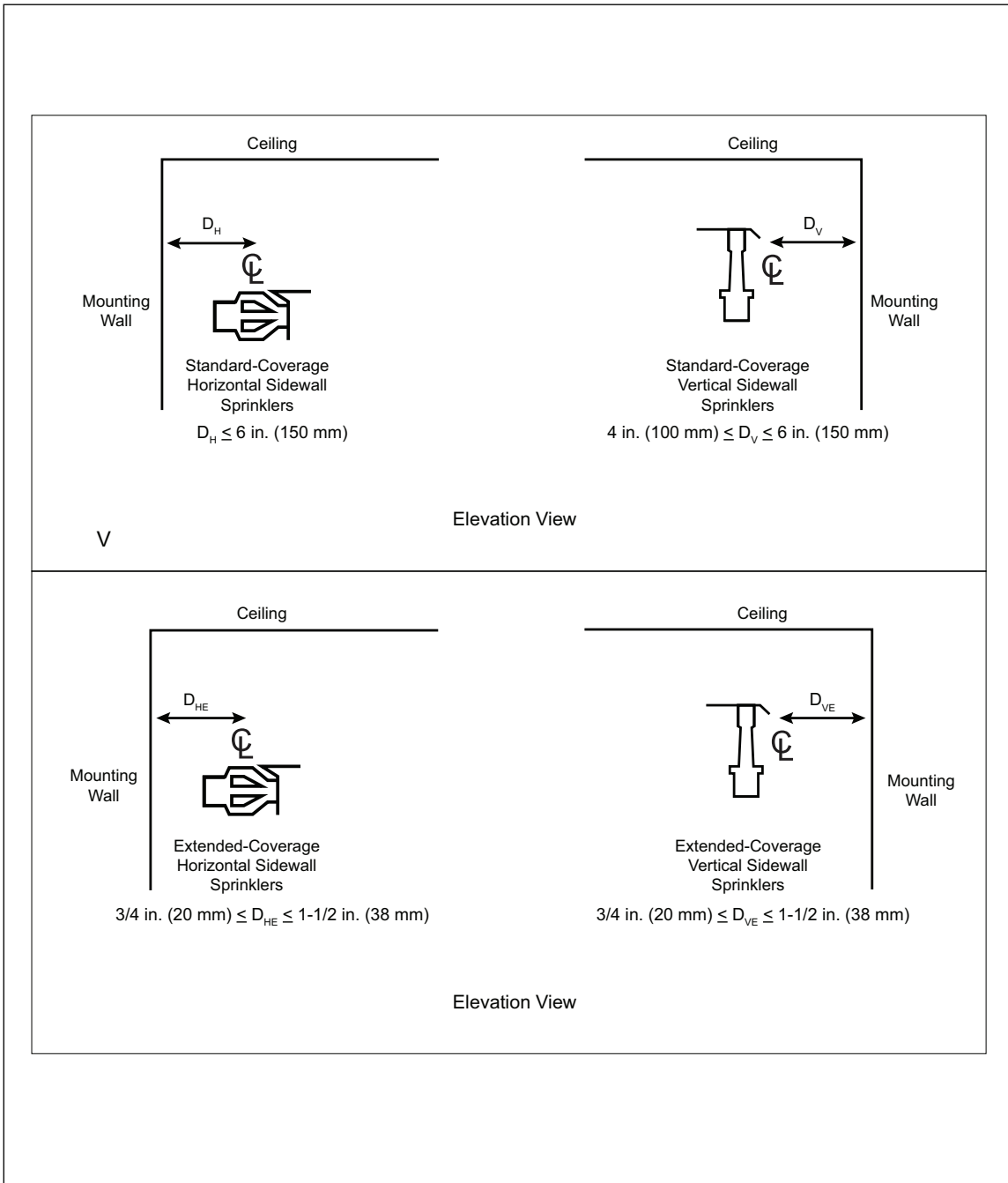

Fig. 2.5.3.2.2.1(a). Horizontal distances from Nonstorage sidewall sprinklers to walls

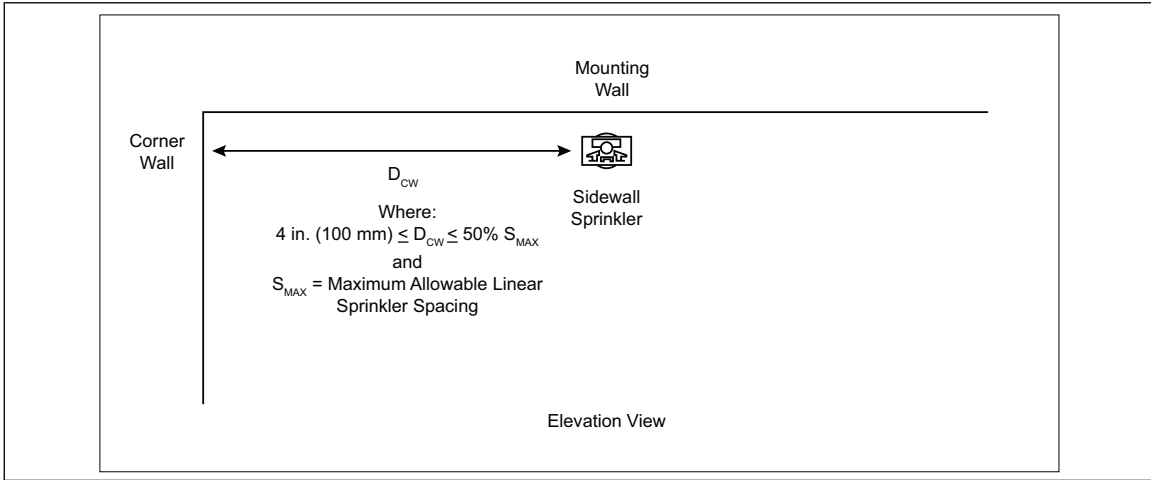

Fig. 2.5.3.2.1(b). Horizontal distances from Nonstorage sidewall sprinklers to wall corners

2.5.3.2.2 See Section 2.5.3.4 for horizontal positioning recommendations regarding the K14.0EC (K200EC) horizontal sidewall sprinkler.

**2.5.3.3 Vertical Location of Nonstorage Sidewall Sprinklers**

2.5.3.3.1 Install the centerline of a Nonstorage sidewall sprinkler’s thermal element vertically below the underside of the ceiling as shown in Figure 2.5.3.3.1.

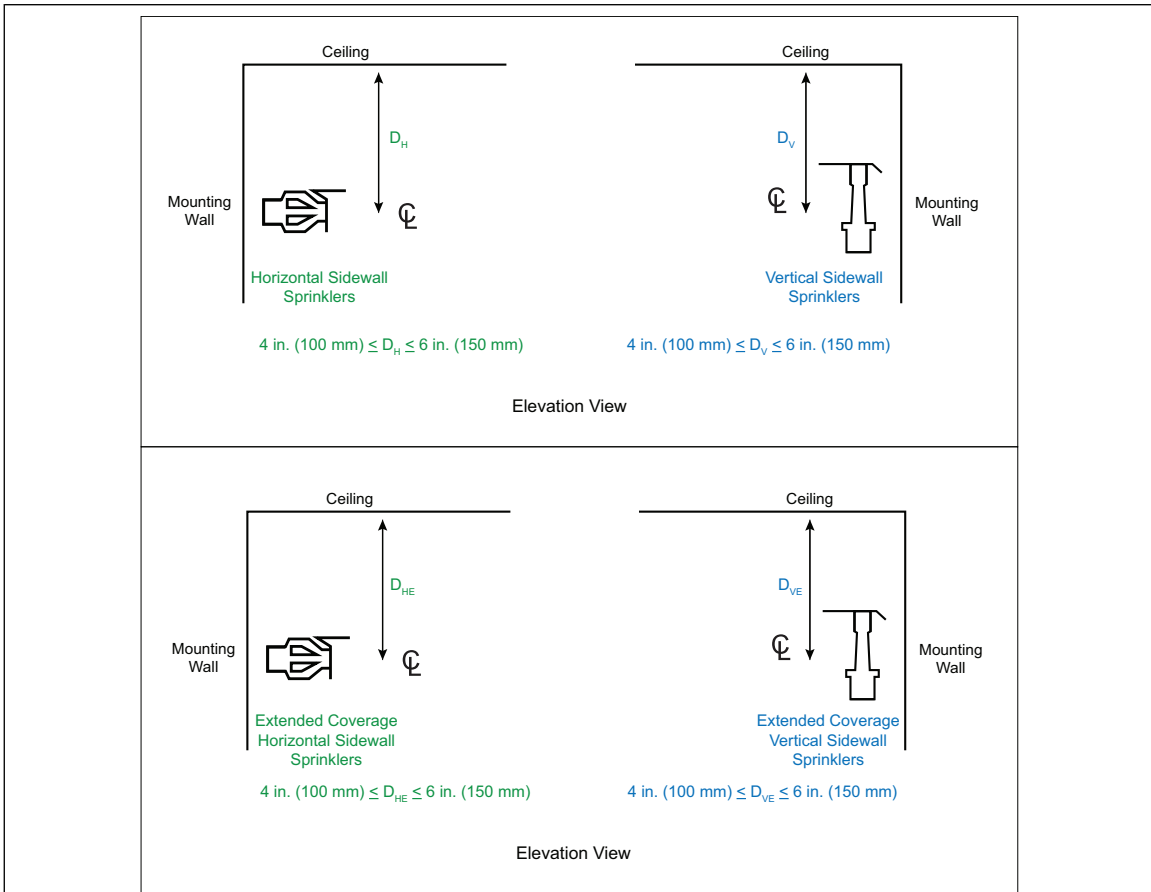

Fig. 2.5.3.3.1. Vertical location of Nonstorage sidewall sprinklers

2.5.3.3.2 See the *Approval Guide* for potential increased vertical distances below the ceiling that certain sprinklers can be installed.

2.5.3.3.3 Locate the sidewall sprinklers as shown in Figure 2.5.3.3.3 if the ceiling slope exceeds (5°) 1 in 12.

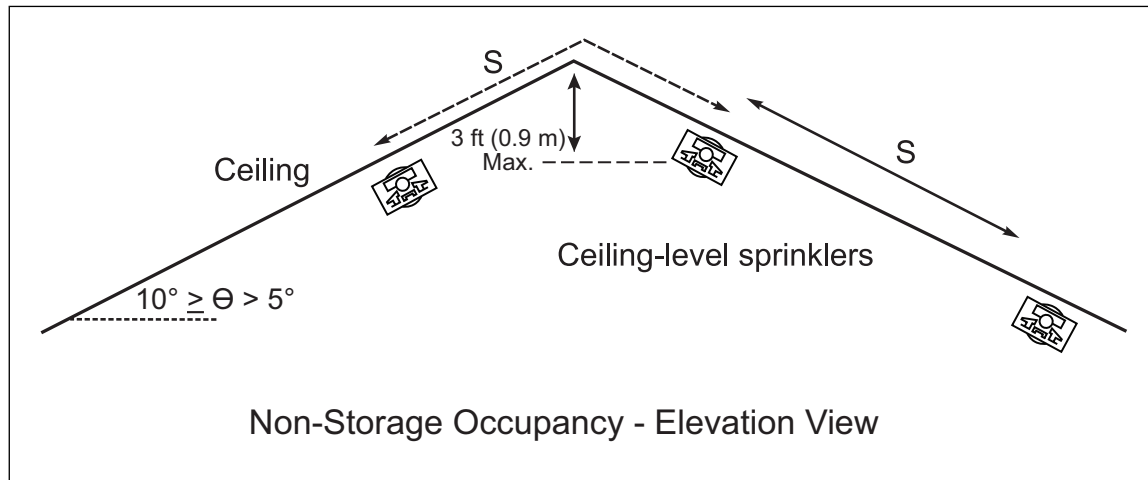

Fig. 2.5.3.3.3. Location of Nonstorage sidewall sprinklers near ceiling peak when slope exceeds 1 in 12 (5°)

#### 2.5.3.4 Installation Guidelines for Nonstorage K14.0EC (K200EC) Horizontal Sidewall Sprinklers

2.5.3.4.1 The K14.0EC (K200EC) horizontal sidewall sprinklers are acceptable for use under the following conditions:

- A. The occupancy hazard qualifies as HC-1, HC-2, HC-3, or incidental storage, as defined in Data Sheet 3-26, *Fire Protection for Nonstorage Occupancies*, and
- B. The occupancy is compatible with quick-response sprinklers (see Section 2.5.2.1.2.2 for occupancies not compatible with quick-response sprinklers), and
- C. The ceiling construction type qualifies as unobstructed. The ceiling construction can qualify as obstructed with the presence of purlins on girders/l-beams if:
  1. The depth of the purlins is limited to 10 in. (250 mm), and
  2. The structural supports are no more than 25 ft (7.6 m) apart and have a maximum bottom chord width of 10 in. (250 mm), and
- D. The ceiling height of the protected area does not exceed 32 ft (9.8 m), and
- E. The slope of the ceiling does not exceed 2 in 12 (10°).

2.5.3.4.2 Install 160°F (70°C) nominally rated K14.0EC (K200EC) horizontal sidewall sprinklers unless the ambient temperature of the protected area requires a nominal temperature rating of 212°F (100°C) instead.

2.5.3.4.3 Arrange the deflector of the K14.0EC (K200EC) horizontal sidewall sprinklers so that it is parallel to the floor.

2.5.3.4.4 Other than vacuum sprinkler systems, there are no limitations on the type of sprinkler system the K14.0EC (K200EC) horizontal sidewall sprinklers can be installed on.

2.5.3.4.5 Install the K14.0EC (K200EC) horizontal sidewall sprinkler on the linear and area spacings indicated in Table 2.5.3.4.5. Note that the minimum spacing indicated in the table does not apply to sprinklers located back-to-back on both sides of a beam.

Table 2.5.3.4.5. Recommended Spacing of Nonstorage K14.0EC (K200EC) Horizontal Sidewall Sprinklers for Hazard Category Nos. 1, 2, and 3

Ceiling Construction Type	K-Factor	RTI Rating	Linear Spacing				Area Spacing	Max., ft <sup>2</sup> (m <sup>2</sup> )
			Along the Mounting Wall		Away from the Mounting Wall			
			Min., ft (m)	Max., ft (m)	Min., ft (m)	Max., ft (m)	Min., ft <sup>2</sup> (m <sup>2</sup> )	
Per Section 2.5.3.4.1(C)	14.0EC (200EC)	Quick	8 (2.4)	14 (4.3)	8 (2.4)	12.5 (3.8)	64 (5.9)	175 (16.3)

2.5.3.4.6 Install the sprinklers on each side of the primary structural members so they are back-to-back and position the sprinklers horizontally as shown in Figure 2.5.3.4.6.

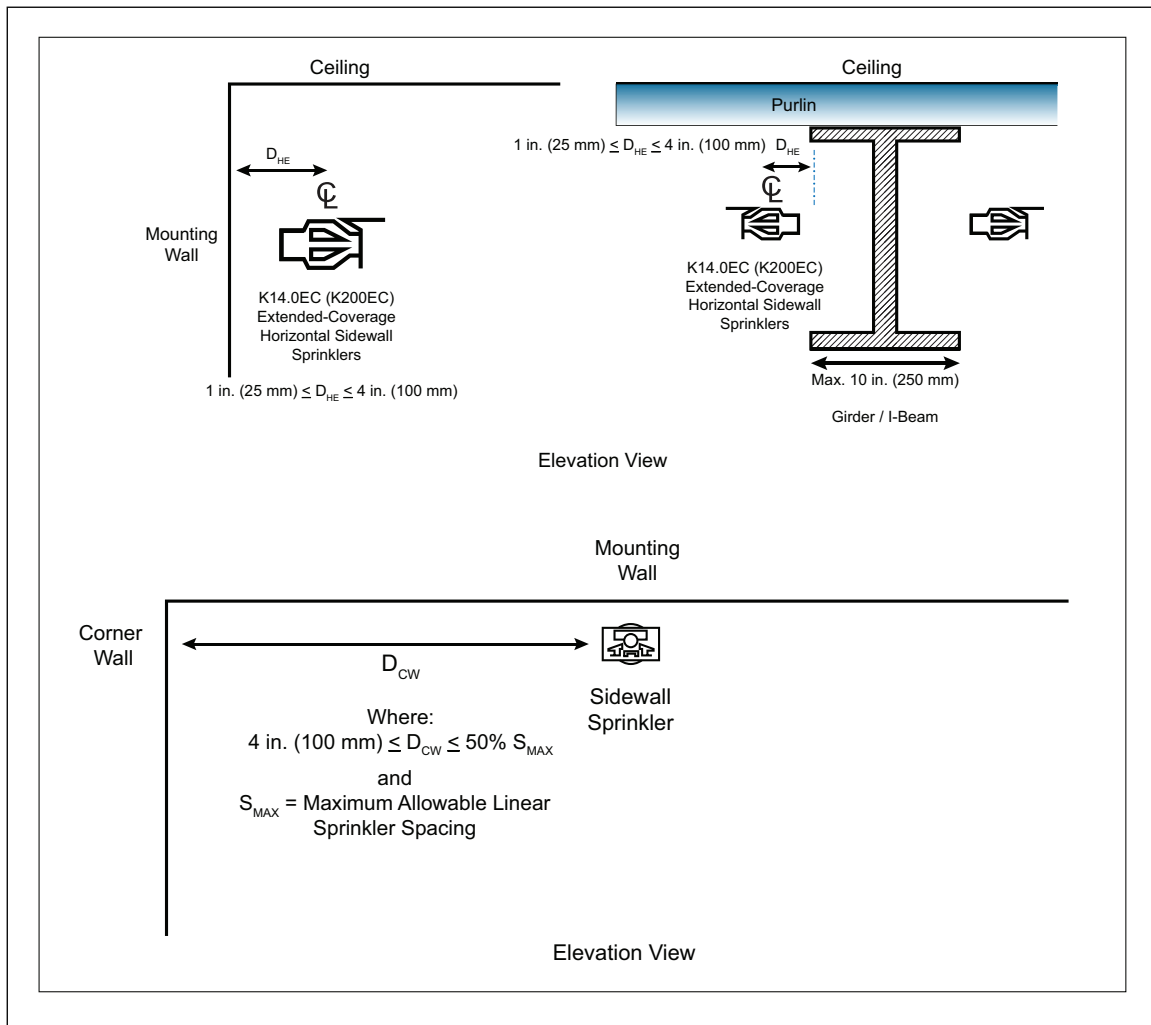

Fig. 2.5.3.4.6. Horizontal distances from Nonstorage K14.0EC (K200EC) horizontal sidewall sprinkler to walls

2.5.3.4.7 Locate the sprinklers so that the sprinkler deflectors are (1) a minimum 4 in. (100 mm) and a maximum 6 in. (150 mm) below the underside of the ceiling when installed against a mounting wall, or (2) a minimum 12 in. (300 mm) and a maximum 16 in. (400 mm) below the underside of the ceiling when installed against an I-beam or a similar ceiling structural member. See Figure 2.5.3.4.7 for a demonstration of this guidance.

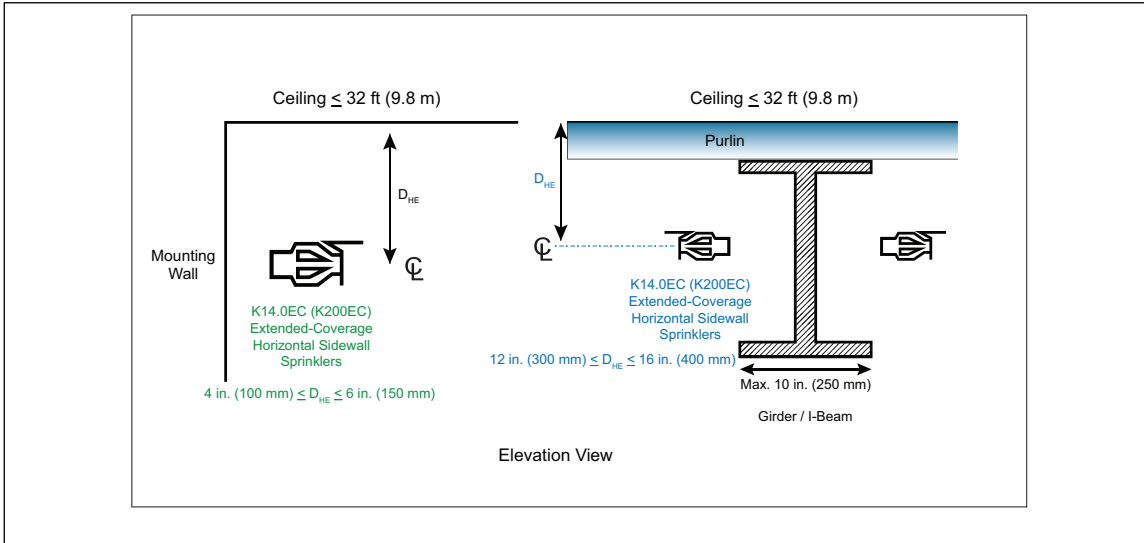

Fig. 2.5.3.4.7. Vertical location of Nonstorage K14.0EC (K200EC) horizontal sidewall sprinklers below ceiling

2.5.3.4.8 Arrange the sprinklers relative to the roof peak so that:

- A. A sprinkler is located at the roof peak, or
- B. Sprinklers on either side of the roof peak are located equally-distant 4 ft (1.2 m) horizontally from the centerline of the roof peak as measured parallel to the floor.

See Figure 2.5.3.4.8 for a visual representation of this guidance.

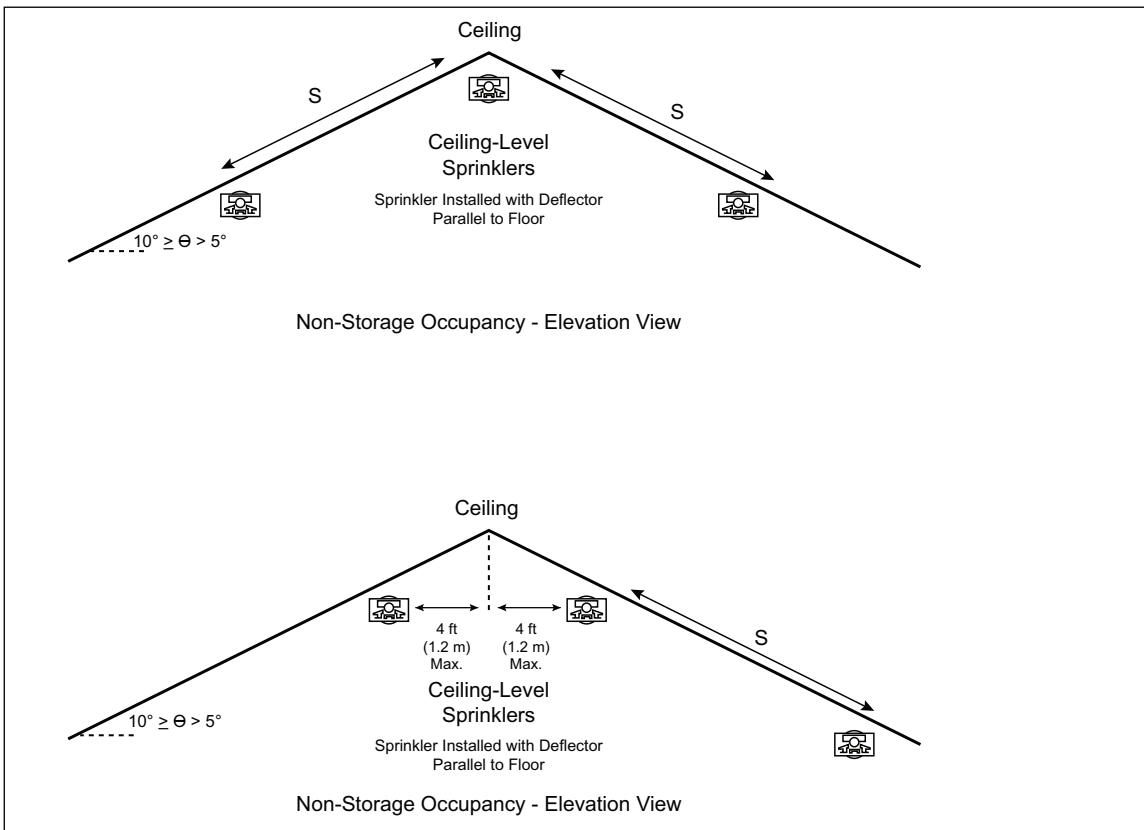

Fig. 2.5.3.4.8. Vertical location of Nonstorage K14.0EC (K200EC) horizontal sidewall sprinklers at roof peak

2.5.3.4.9 The minimum clearances between sprinkler deflectors and any hazard being protected is 10 ft (3.0 m).

2.5.3.4.10 Use the guidelines in Section 2.5.3.5 to evaluate the potential for objects located below the sprinkler deflector to cause obstruction to the sprinkler's discharge pattern.

2.5.3.4.11 Maintain a minimum pressure of 7 psi (0.5 bar) when designing the sprinkler system with the K14.0EC (K200EC) horizontal sidewall sprinkler.

### 2.5.3.5 Obstructions to Ceiling-Level Nonstorage Sidewall Sprinklers

#### 2.5.3.5.1 General Recommendations for Obstructions to Ceiling-Level Nonstorage Sidewall Sprinklers

2.5.3.5.1.1 Any object located entirely within the checkerboard area of Figure 2.5.3.5.1.1(a) for standard-coverage sidewall sprinklers or Figure 2.5.3.5.1.1(b) for extended-coverage sidewall sprinklers does not qualify as an obstruction to the sprinkler's discharge pattern away from the mounting wall.

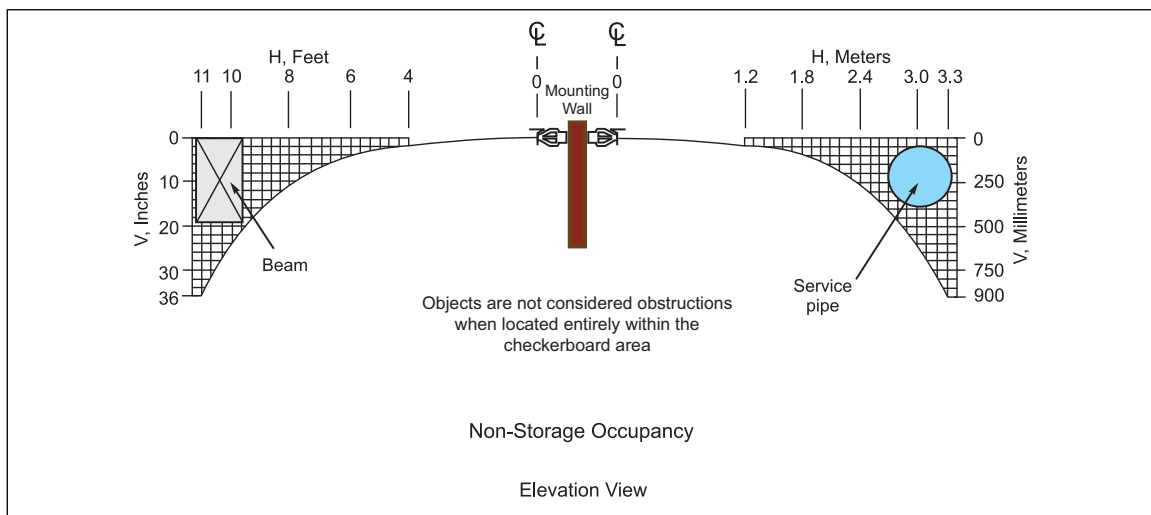

Fig. 2.5.3.5.1.1(a). Objects near ceiling level not considered obstructions to standard-coverage Nonstorage sidewall sprinklers away from the mounting wall

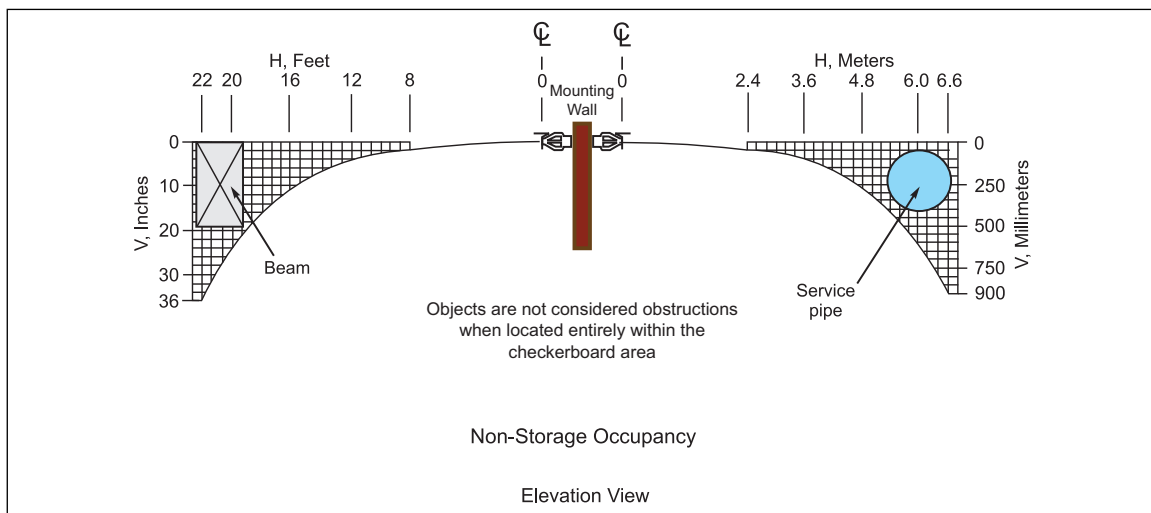

Fig. 2.5.3.5.1.1(b). Objects near ceiling level not considered obstructions to extended-coverage Nonstorage sidewall sprinklers away from the mounting wall

2.5.3.5.1.2 Any object located entirely within the checkerboard area of Figure 2.5.3.5.1.2(a) for standard-coverage sidewall sprinklers or Figure 2.5.3.5.1.2(b) for extended-coverage sidewall sprinklers does not qualify as an obstruction to the sprinkler's discharge pattern along the mounting wall.

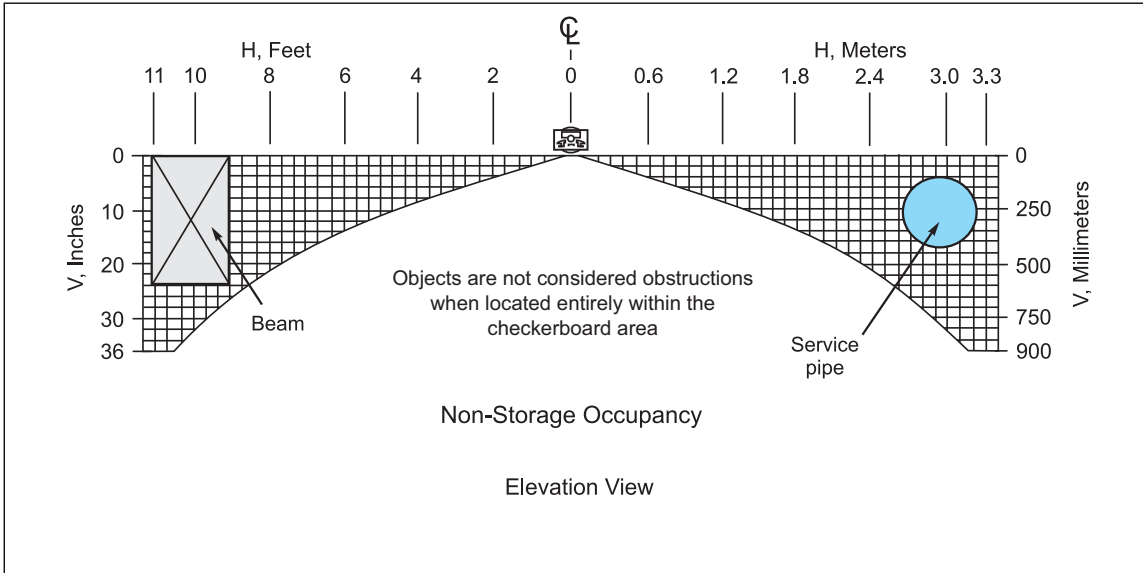

Fig. 2.5.3.5.1.2(a). Objects near ceiling level not considered obstructions to standard-coverage Nonstorage sidewall sprinklers along the mounting wall

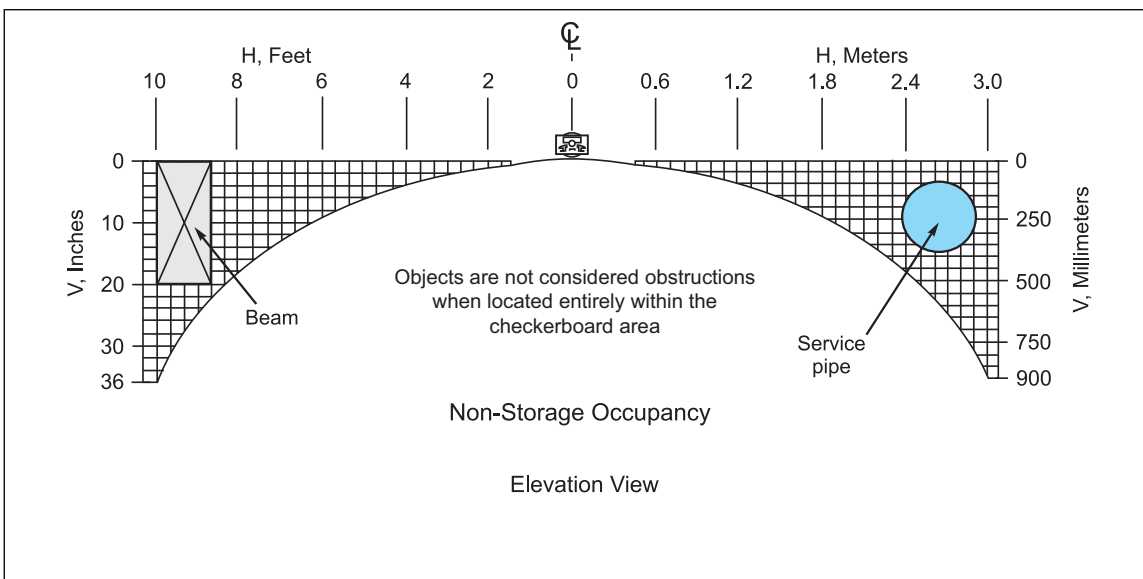

Fig. 2.5.3.5.1.2(b). Objects near ceiling level not considered obstructions to extended-coverage Nonstorage sidewall sprinklers along the mounting wall

2.5.3.5.1.3 If an object is not located entirely within the checkerboard, see the following sections to determine whether the object qualifies as an unacceptable obstruction to the sprinkler's discharge pattern.

### 2.5.3.5.2 Ceiling Structural Members or Other Similar Objects Located Near Ceiling-Level Sidewall Sprinklers

2.5.3.5.2.1 If ceiling structural members or other similar objects that are less than 70% open in their vertical profile extend down out of the checkerboard pattern, as demonstrated in Figure 2.5.3.5.2.1(a), position sprinklers on the opposite side of the ceiling structural member or object as shown in Figure 2.5.3.5.2.1(b).

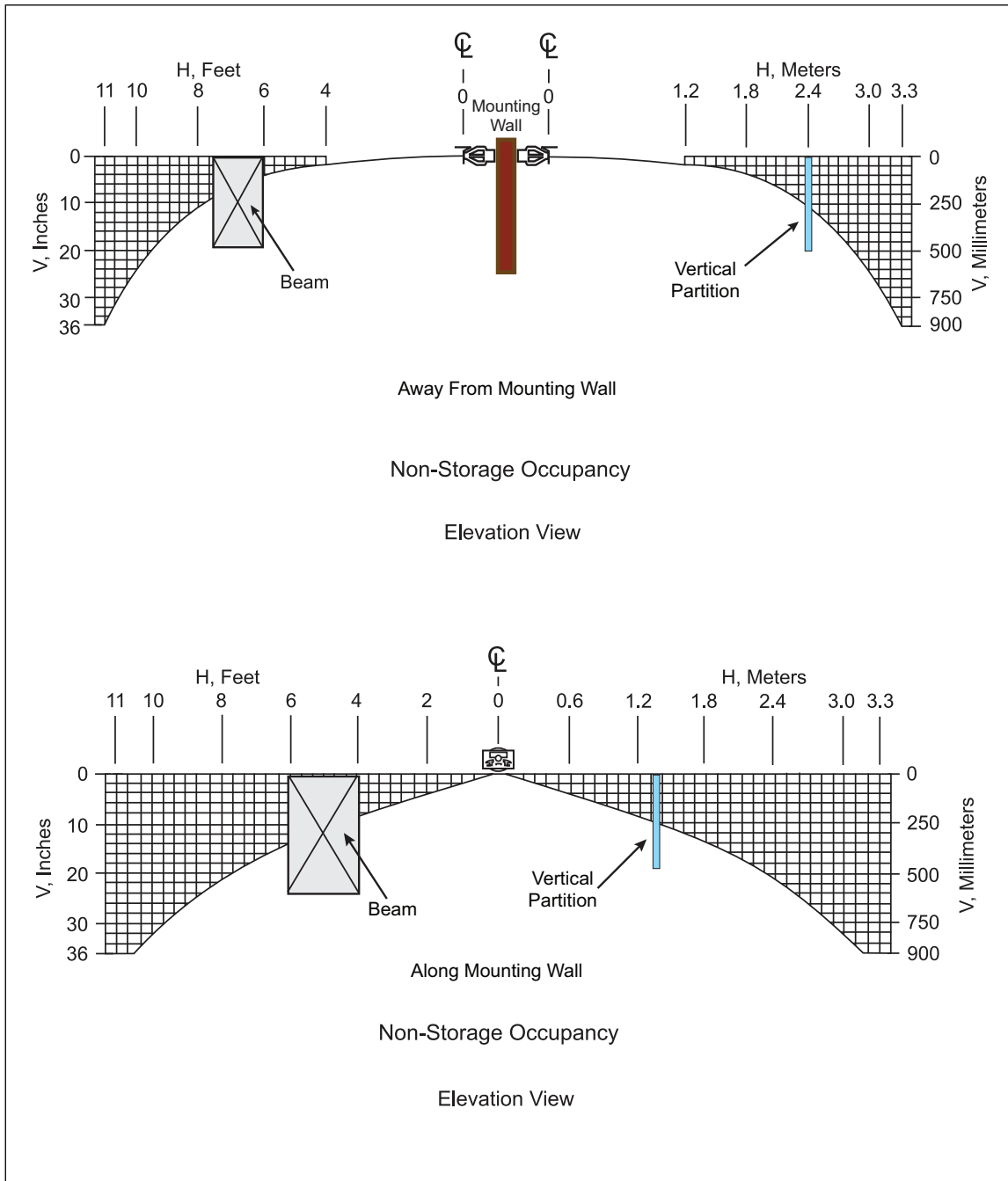

Fig. 2.5.3.5.2.1(a). Example of ceiling structural members that obstruct sidewall sprinkler discharge pattern

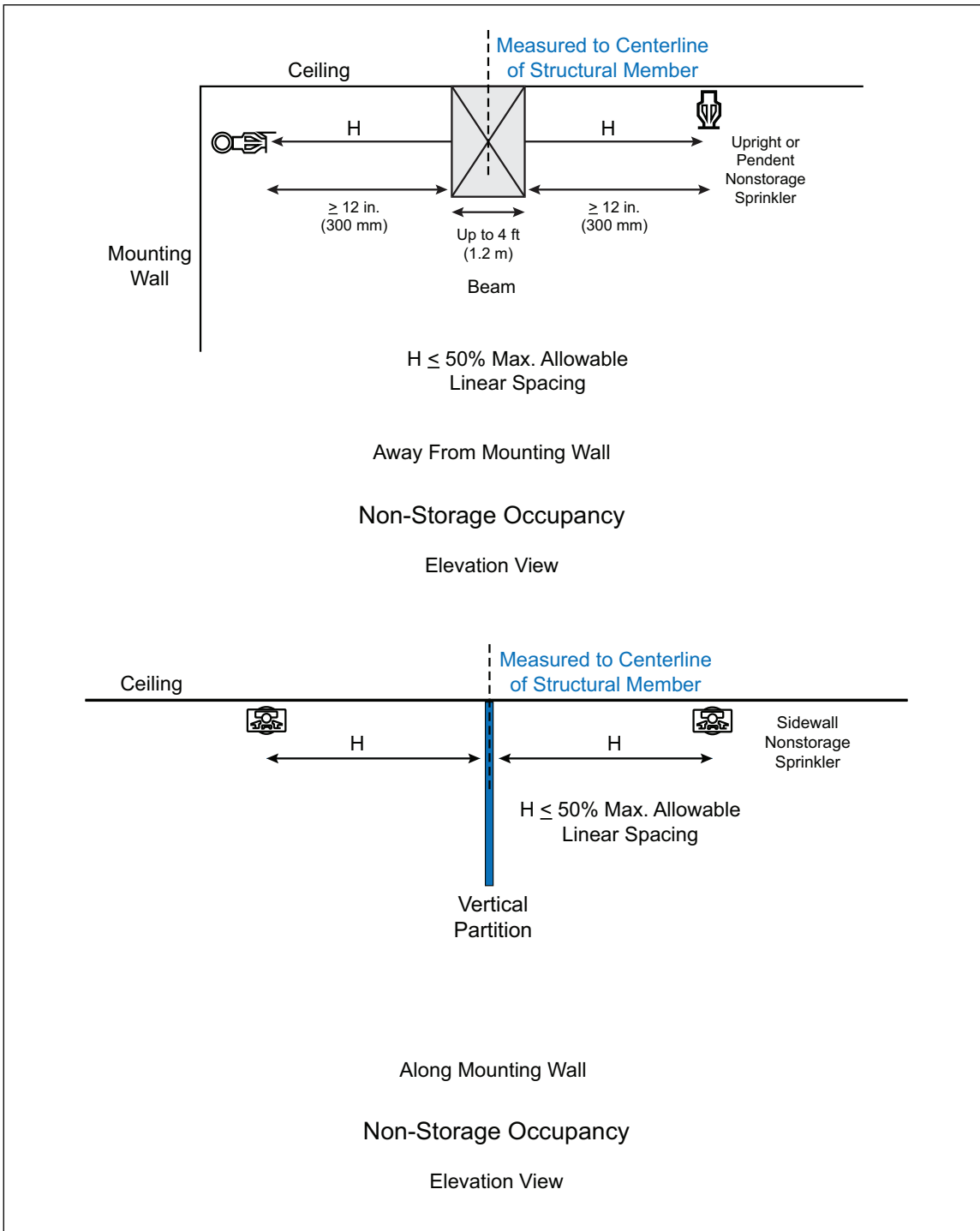

Fig. 2.5.3.5.2.1(b). Positioning ceiling-level sprinklers when ceiling structural members obstruct sprinkler discharge

2.5.3.5.2.2 Ceiling structural members or other similar objects that are 70% or more open in their vertical profile do not qualify as obstructions to the sprinkler's discharge pattern.

2.5.3.5.2.3 If ceiling structural members or other similar objects are a minimum of 70% open in their vertical profile, but are located less than 4 ft (1.2 m) horizontally away from standard-coverage sidewall sprinklers, or less than 8 ft (2.4 m) horizontally away from extended-coverage sidewall sprinklers, ensure that any cross-bracing or similar objects that make up the structural member are:

- A. No wider than 3 in. (75 mm), and
- B. Located a minimum horizontal distance of three times the width of the object from the sprinkler.

2.5.3.5.2.4 If the guidelines of Section 2.5.3.5.2.3 cannot be met, position sprinklers on the opposite side of the ceiling structural member or object as shown in Figure 2.5.3.5.2.1(b).

2.5.3.5.2.5 For areas protected by Nonstorage sidewall sprinklers, install Nonstorage sprinklers under combustible shielded areas if a non-continuous vertical wall creates such an area more than 8 in. (200 mm) deep below the Nonstorage sidewall sprinkler. See Figure 2.5.3.5.2.5 for an example of this arrangement.

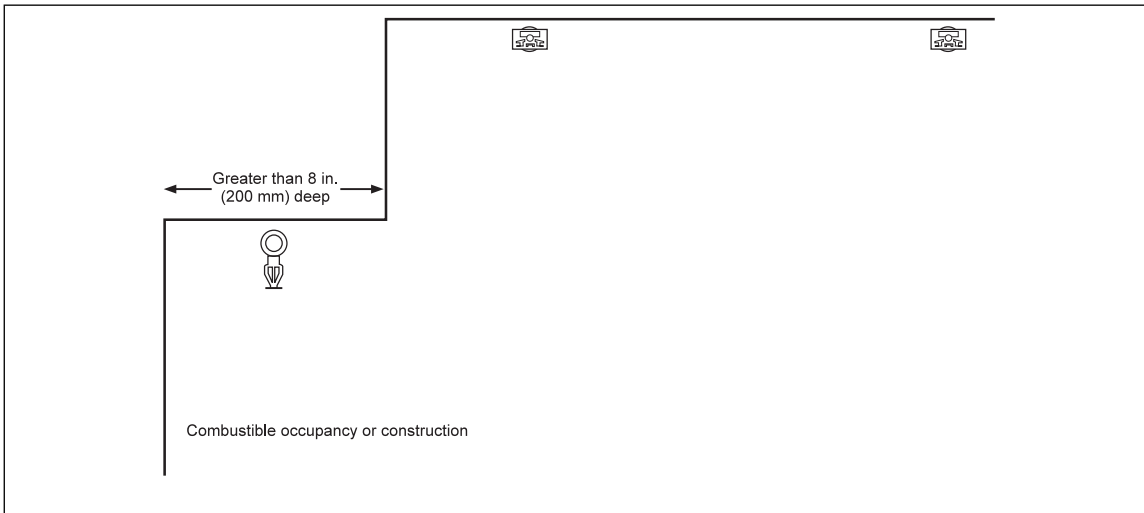

Fig. 2.5.3.5.2.5. Nonstorage sprinklers under combustible shielded areas more than 8 in. (200 mm) deep

### 2.5.3.5.3 Individual or Grouped Objects Located Below Ceiling-Level Sidewall Sprinklers

2.5.3.5.3.1 An object can be considered an “individual object” for the purpose of analyzing it as a potential obstruction to ceiling sprinkler discharge if it is located a minimum of 3 times its width from an adjacent object that is either the same size or larger. See Figure 2.5.3.5.3.1 for an example of applying this guidance.

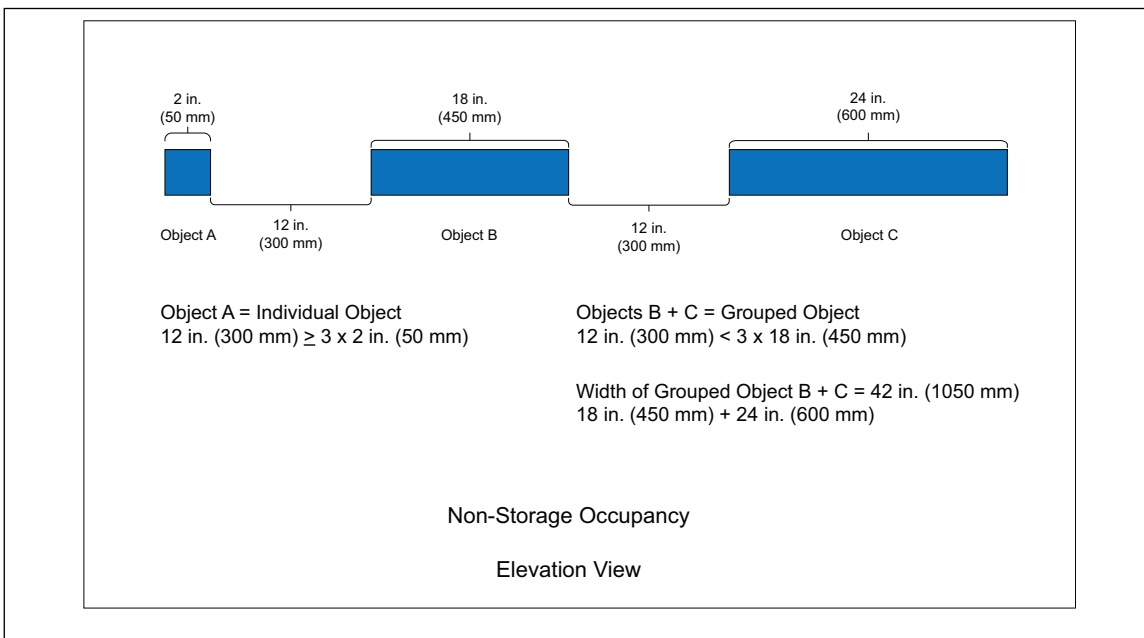

Fig. 2.5.3.5.3.1. Example of an “Individual Object” and a “Grouped Object” for analyzing obstructions

2.5.3.5.3.2 Group an object with an adjacent object of the same size or larger if the horizontal distance between the two objects is less than 3 times the width of the smaller object. See Figure 2.5.3.5.3.1 for an example of applying this guidance.

2.5.3.5.3.3 If two or more objects are considered a “grouped object”, their overall width is the collective sum of each of the objects that make-up the grouped object; the open spaces between them do not need to be included in the calculation as demonstrated in Figure 2.5.3.5.3.1.

#### **2.5.3.5.4 Objects Up to 4 ft (1.2 m) Wide Located Below Ceiling-Level Sidewall Sprinklers**

An object up to 4 ft (1.2 m) wide is not considered an obstruction to the sprinkler’s discharge pattern.

#### **2.5.3.5.5 Objects Over 4 ft (1.2 m) Wide Located Below Ceiling-Level Sidewall Sprinklers**

2.5.3.5.5.1 For individual or grouped objects over 4 ft (1.2 m) wide, design and install supplemental sprinklers under the obstructing object in accordance with Sections 2.5.3.5.5.2 through 2.5.3.5.5.4.

2.5.3.5.5.2 The design for the supplemental sprinklers is considered acceptable and does not need to be hydraulically balanced or accounted for in the ceiling sprinkler design when all the following conditions are met:

- A. The supplemental sprinklers are fed from a wet (or similar) sprinkler system, and
- B. The pipe size feeding the supplemental sprinklers is equal to or larger than the branch line pipe size of the overhead ceiling sprinkler system, and
- C. The supplemental sprinklers will have the same attributes (characteristics) as the ceiling sprinklers. Acceptable attribute differences include (1) the supplemental sprinklers are pendent or upright as opposed to being sidewall, or (2) the supplemental sprinklers are quick-response if the ceiling sprinklers are standard-response, or (3) the K-factor of the supplemental sprinklers is greater than the K-factor of the ceiling sprinklers, or (4) the nominal temperature rating of the supplemental sprinklers is lower than the nominal temperature rating of the ceiling sprinklers.

2.5.3.5.5.3 Where the guidelines of Section 2.5.3.5.5.2 are not met, the design for the supplemental sprinklers, for the purpose of sizing the pipe feeding them, is determined as follows:

- A. Obtain the recommended density from the occupancy-specific data sheet for the occupancy hazard located below the obstruction by using the bottom of the obstruction, under which the supplemental sprinklers will be installed, as the “ceiling height” for design purposes, and
- B. Include all the supplemental sprinklers for the affected area, up to a maximum of four, in the design area. If more than one branch line will feed the supplemental sprinklers, the four sprinklers in the design can be accounted for using two sprinklers on two lines, and
- C. The required flow and pressure for the supplemental sprinkler design does not need to be hydraulically balanced with the overhead ceiling sprinkler system.

2.5.3.5.5.4 Install the supplemental sprinklers as follows:

- A. Position the supplemental sprinklers on a vertical plane as close to the underside of the obstructing object as possible.
- B. Install the supplemental sprinklers horizontally within the footprint of the obstructing object using the linear and area spacing guidelines indicated in either Table 2.5.2.3.1.1(a), Table 2.5.2.3.1.1(b), or Table 2.5.2.3.1.1(c), depending on (1) the occupancy hazard being protected, and (2) the attributes of the supplemental sprinkler being installed.

#### **2.5.3.5.6 Obstruction to Ceiling-Level Nonstorage Sidewall Sprinkler Discharge Due to Open-Grid Ceilings**

2.5.3.5.6.1 Do not install an open-grid ceiling (see Appendix A) in areas protected by sidewall sprinklers unless the occupancy is classified as a HC-1 hazard category, as defined per Data Sheet 3-26, *Fire Protection Water Demand for Nonstorage Sprinklered Properties*.

2.5.3.5.6.2 When an open-grid ceiling consisting of uniform openings that constitute at least 70% of the ceiling area will be installed in the presence of HC-1 occupancies, install the sprinklers located at ceiling-level in accordance with Table 2.5.3.5.6.2.

*Table 2.5.3.5.6.2. Recommended Spacing Guidelines for Ceiling Sidewall Sprinklers in the Presence of an Open-Grid Ceiling*

<i>Vertical Depth of Open-Grid Ceiling</i>	<i>Clearance Between Sprinkler Deflectors and Top of Open-Grid Ceiling</i>	<i>Maximum Allowable Linear Spacing</i>
≤ 1/2 in. (13 mm)	≥ 18 in. (450 mm)	10 ft (3.0 m)
	≥ 24 in. (600 mm)	12 ft (3.7 m)
	≥ 48 in. (1200 mm)	Treat as if the open-grid ceiling is not present.
> 1/2 in. (13 mm)	≥ 48 in. (1200 mm)	Treat as if the open-grid ceiling is not present.
≤ 1/4 in. (7 mm)	≥ 24 in. (600 mm)	10 ft (3.0 m)
	≥ 36 in. (900 mm)	Treat as if the open-grid ceiling is not present.
> 1/4 in. (7 mm)	≥ 48 in. (1200 mm)	Treat as if the open-grid ceiling is not present.

## 2.5.4 Storage Sprinklers

### 2.5.4.1 General Recommendations for Storage Sprinklers

See Figure 2.5.4.1 to determine which Storage sprinklers can be installed for a given occupancy when the relevant occupancy-specific data sheet indicates it can be treated as storage.

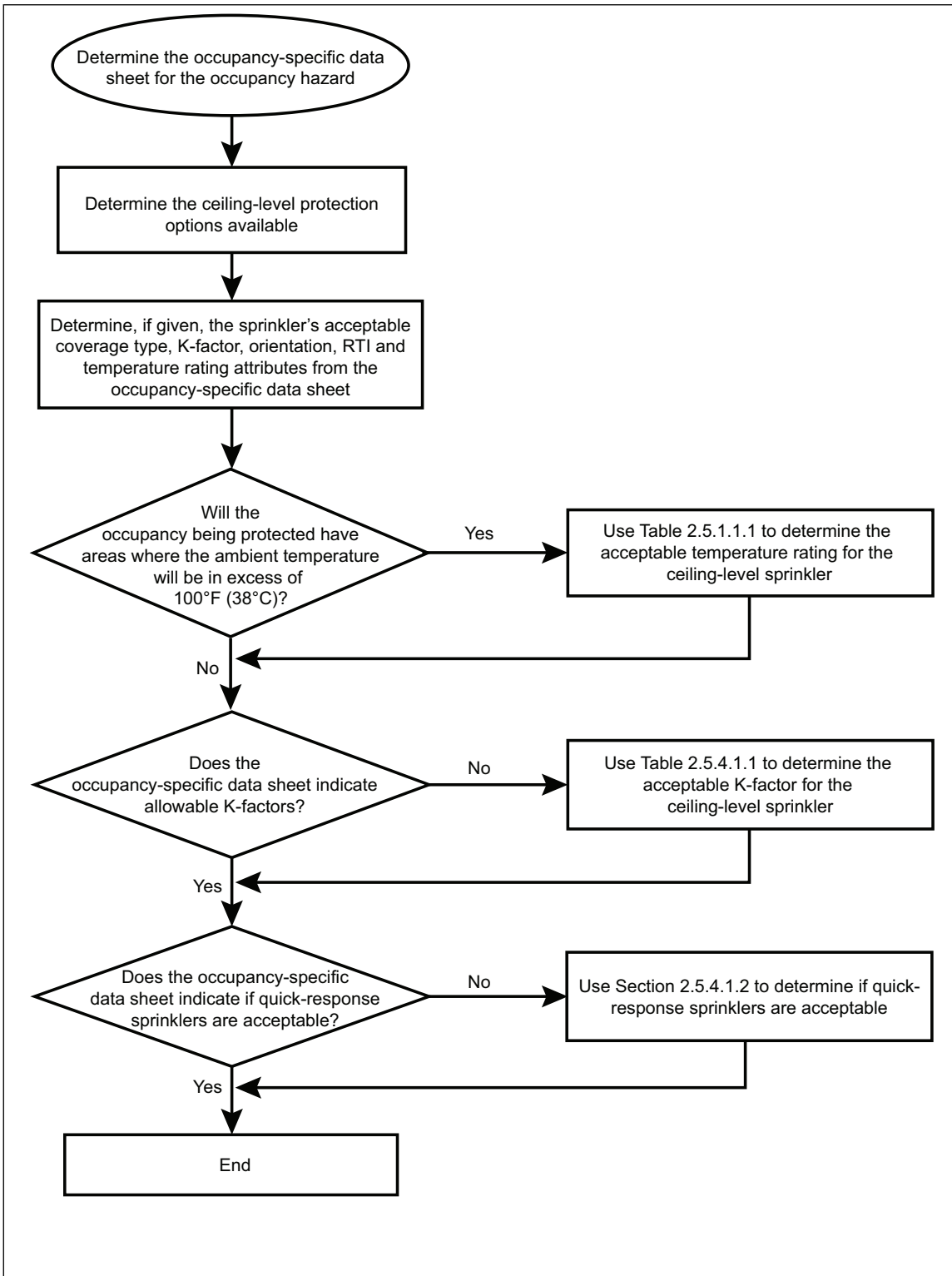

Fig. 2.5.4.1. Flowchart for applicable Storage sprinklers

## 2.5.4.1.1 Acceptable K-factors for Storage Sprinklers

Table 2.5.4.1.1 shows the acceptable K-factors for Storage sprinklers.

Table 2.5.4.1.1. Nominal K-factor Values of FM Approved Storage Sprinklers

Nominal K-factor Values, $gpm/(psi)^{0.5}$ (L/min/[bar] <sup>0.5</sup> )	Nominal Pipe Thread Size, in. (mm)
11.2 (160)	1/2 or 3/4 (15 or 20) <sup>1</sup>
14.0 (200)	3/4 (20)
16.8 (240)	3/4 (20)
19.6 (280)	1 (25)
22.4 (320)	1 (25)
25.2 (360)	1 (25)
28.0 (400)	1 (25)
33.6 (480)	1-1/4 (32)

Note 1. The use of K11.2 (K160) sprinklers having nominal 1/2 in. (15 mm) NPT threaded connections is acceptable only if they are being considered as a retrofit option for the replacement of existing K8.0 (K115) or smaller sprinklers.

## 2.5.4.1.2 Determining Acceptable RTI Ratings for Storage Sprinklers

2.5.4.1.2.1 The installation of standard-response Storage sprinklers is acceptable for both wet-type and dry-type sprinkler systems.

2.5.4.1.2.2 The installation of quick-response Storage sprinklers is acceptable wet type sprinkler systems; however, do not use quick-response sprinklers for the following types of storage or high-heat release type occupancies:

- A. Spray applications of ignitable liquids
- B. Hydraulic equipment using ignitable liquids
- C. Occupancies involving ignitable liquids other than those incidental to a process and are in safety containers having volume capacities of 5 gal (19 L) or less
- D. Vehicle assembly or repair areas where there is fuel in fuel tanks
- E. Occupancies where there are large areas shielded from sprinkler discharge
- F. Areas where oil, dust, lint, or similar combustible residues can accumulate on ceilings and/or building structural support members
- G. Where the occupancy-specific data sheet does not recommend their use for the occupancy being protected

## 2.5.4.1.3 Gravity Heat/Smoke Vents in the Presence of Storage Sprinklers

2.5.4.1.3.1 Do not install gravity heat vents or gravity smoke vents in buildings protected by ceiling-level sprinklers.

2.5.4.1.3.2 If the installation of these types of vents is unavoidable, use the flowchart in Figure 2.5.4.1.3.2(a) when the size of the gravity heat/smoke vent will be equal to or less than 4 ft<sup>2</sup> (0.4 m<sup>2</sup>) or Figure 2.5.4.1.3.2(b) for larger-sized vents.

2.5.4.1.3.3 Where a flat, continuous, false ceiling is to be installed as shown in Figure 2.5.4.1.3.2(c), use minimum 22-gauge (0.7 mm) sheet metal or similar noncombustible material for the false ceiling; and secure it so that it can resist a minimum uplift velocity pressure of 3 lb/ft<sup>2</sup> (14.6 kg/m<sup>2</sup>). A less desirable but acceptable alternative to noncombustible materials includes minimum 3/8 in. (10 mm) plywood (or similar material).

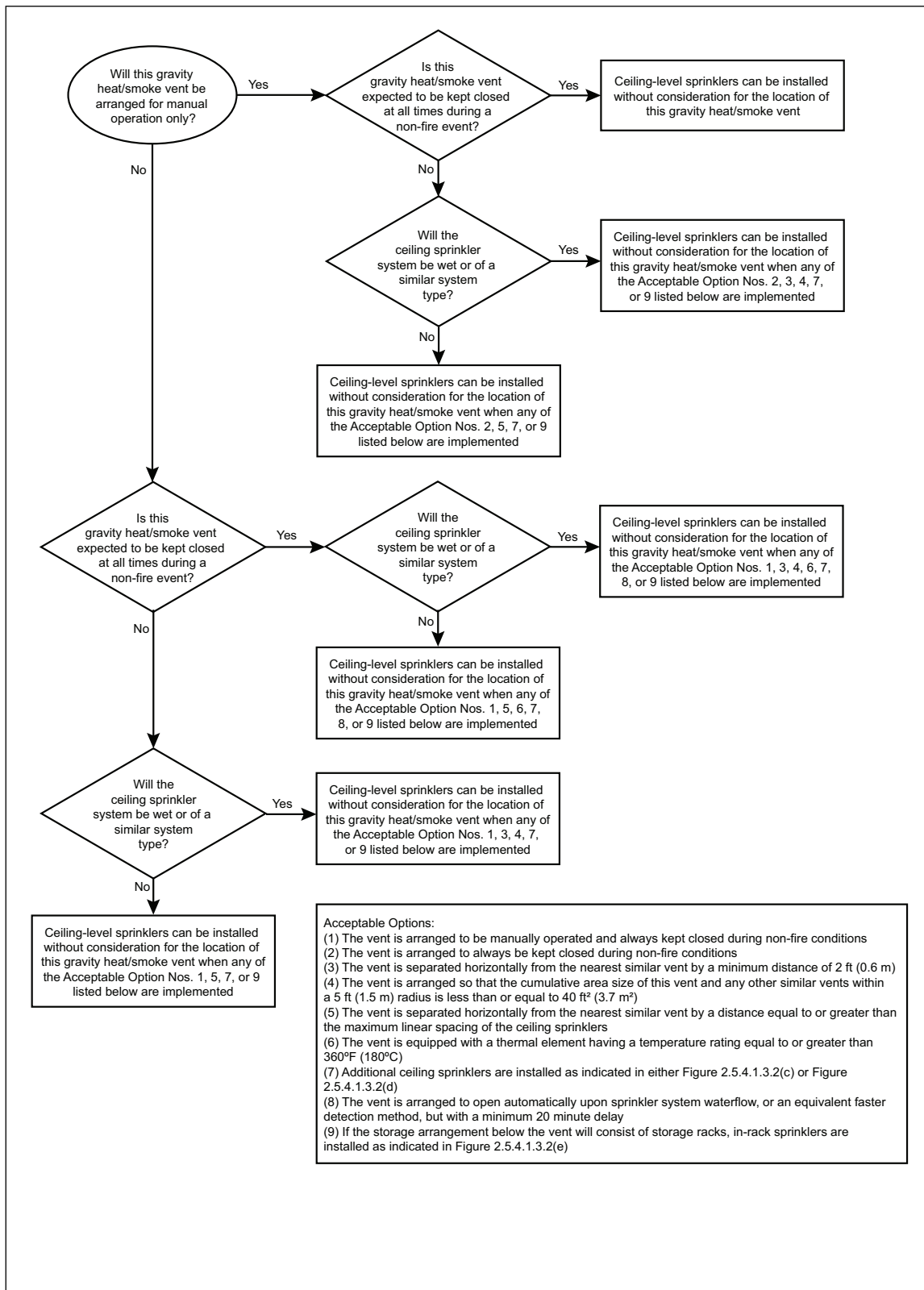

Fig. 2.5.4.1.3.2(a). Flowchart for potential recommendations when a gravity heat/smoke vent less than or equal to 4 ft<sup>2</sup> (0.4 m<sup>2</sup>) in size must be installed over a storage occupancy

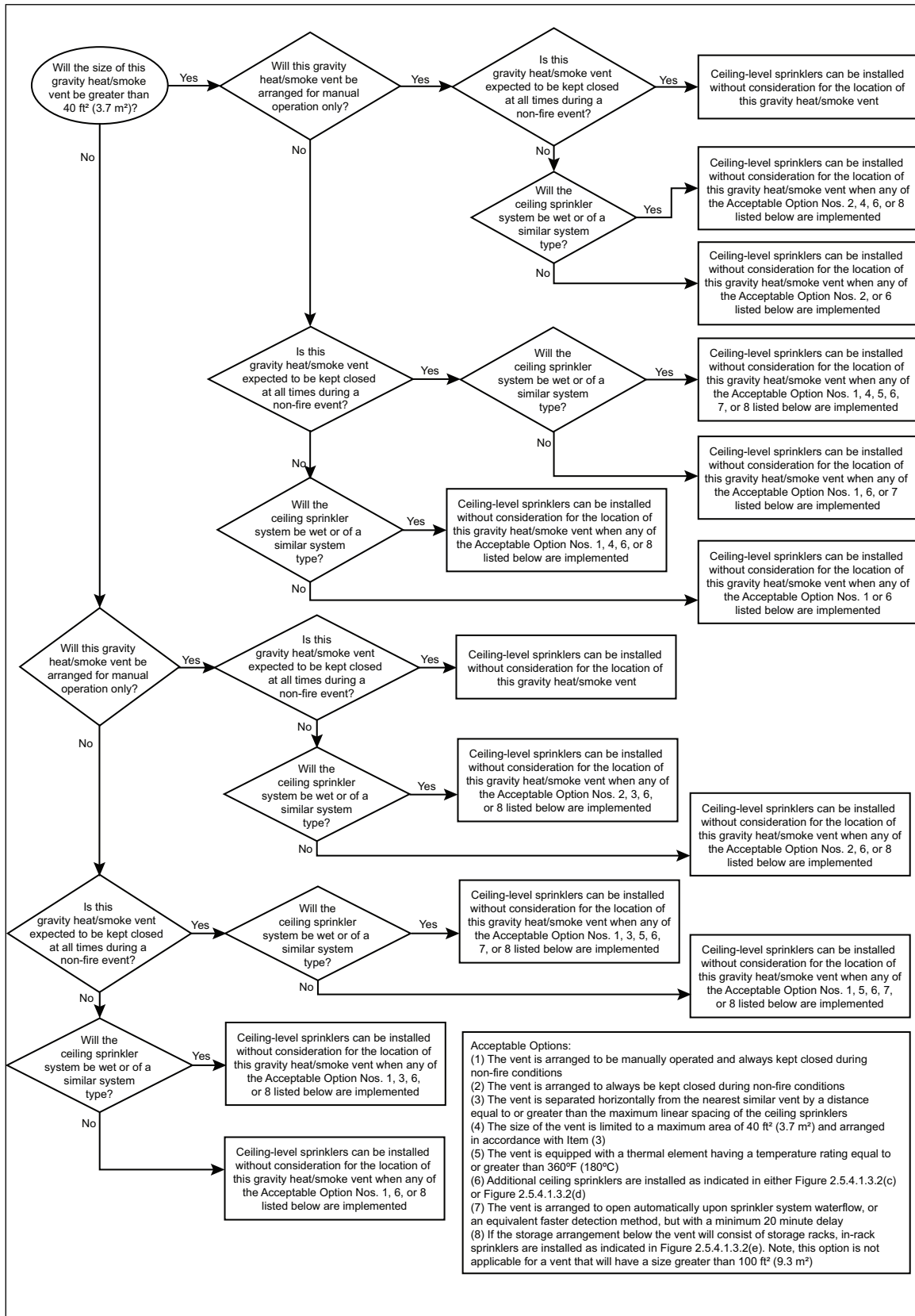

Fig. 2.5.4.1.3.2(b). Flowchart for potential recommendations when a gravity heat/smoke vent larger than 4 ft<sup>2</sup> (0.4 m<sup>2</sup>) in size must be installed over a storage occupancy

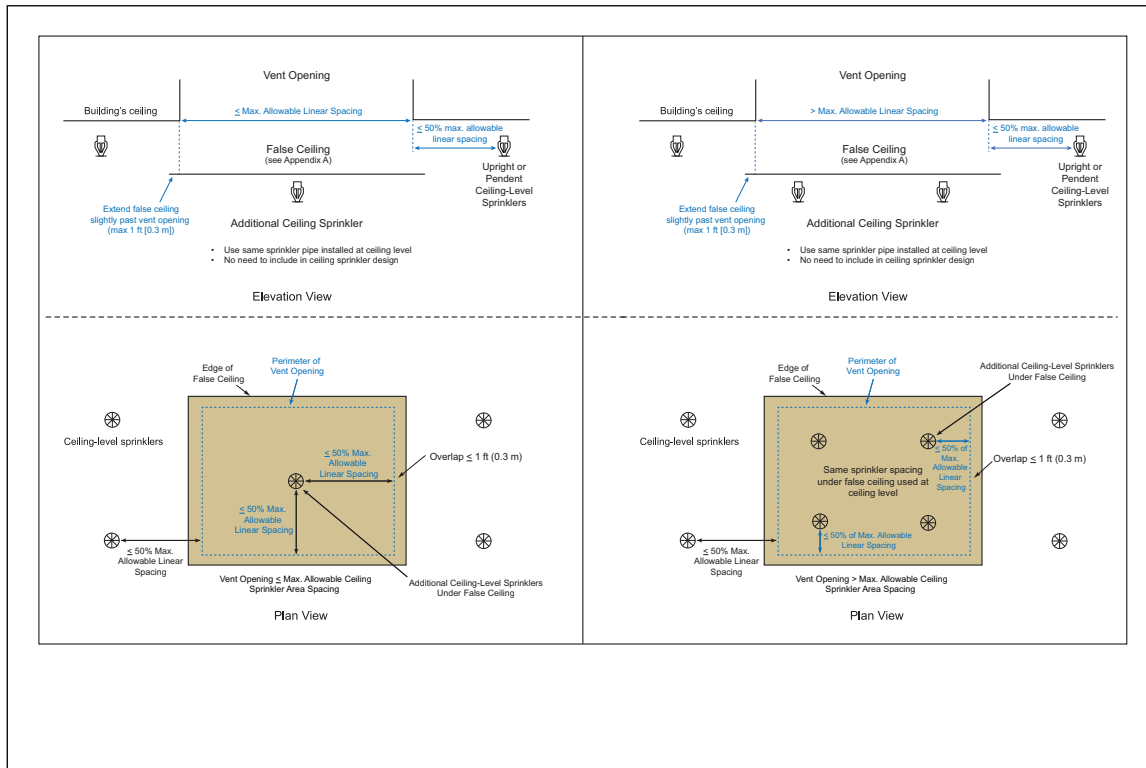

Fig. 2.5.4.1.3.2(c). Protection of vent openings at ceiling level, such as gravity heat/smoke vents, natural draft exhaust vents or mechanical exhaust vents, using a flat, continuous, false ceiling and additional ceiling-level sprinklers

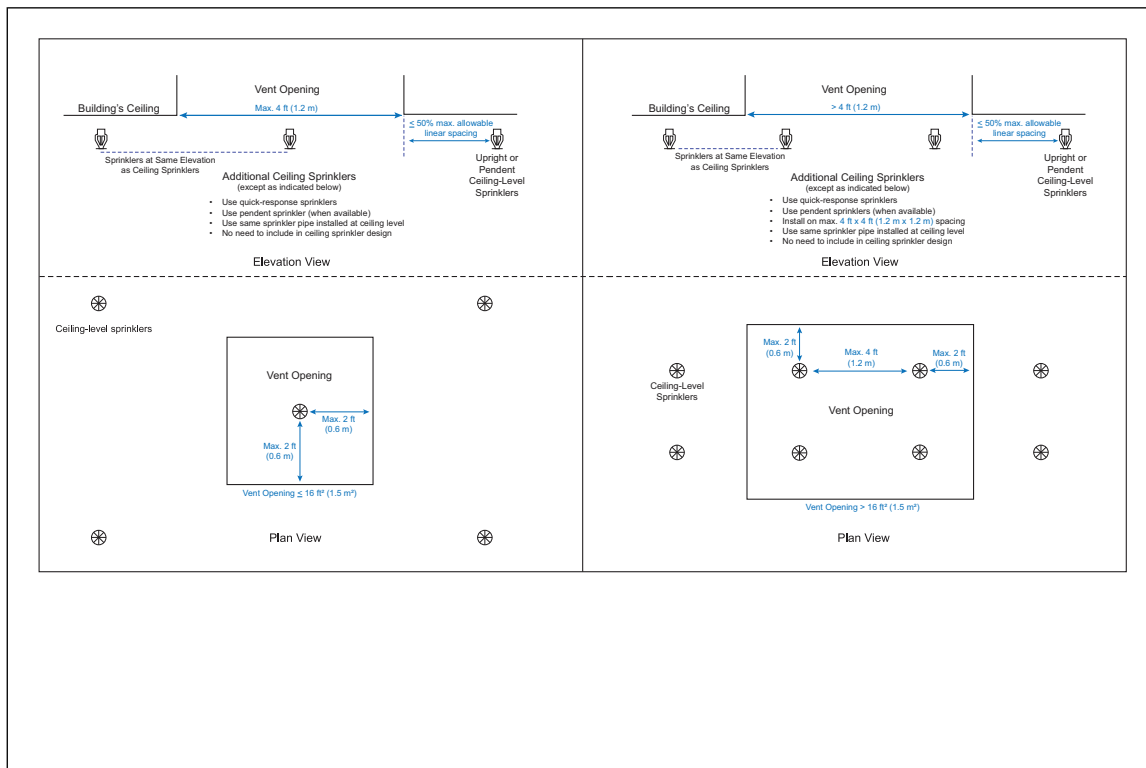

Fig. 2.5.4.1.3.2(d). Protection of vent openings at ceiling level, such as gravity heat/smoke vents, natural draft exhaust vents or mechanical exhaust vents, located over a storage occupancy by the use of additional quick-response, ceiling-level sprinklers

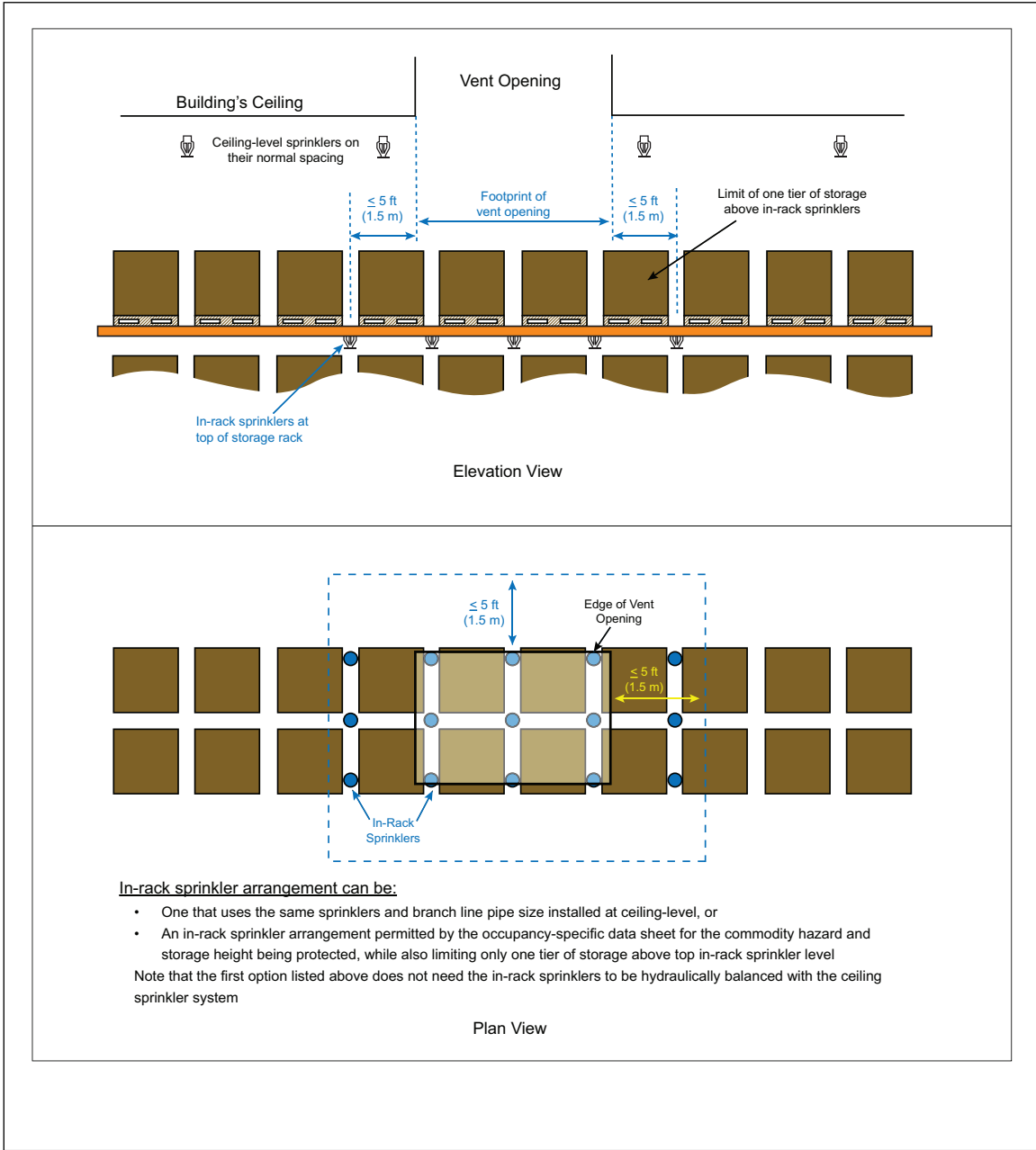

Fig. 2.5.4.1.3.2(e). Protection of vent openings at ceiling level, such as gravity heat/smoke vents, natural draft exhaust vents or mechanical exhaust vents, located over a storage occupancy by the use of in-rack sprinklers

**2.5.4.1.4 Natural Draft Exhaust Vents in the Presence of Storage Sprinklers**

Use the flowchart in Figure 2.5.4.1.4 to determine if corrective action is needed due to the presence of a natural draft exhaust vent.

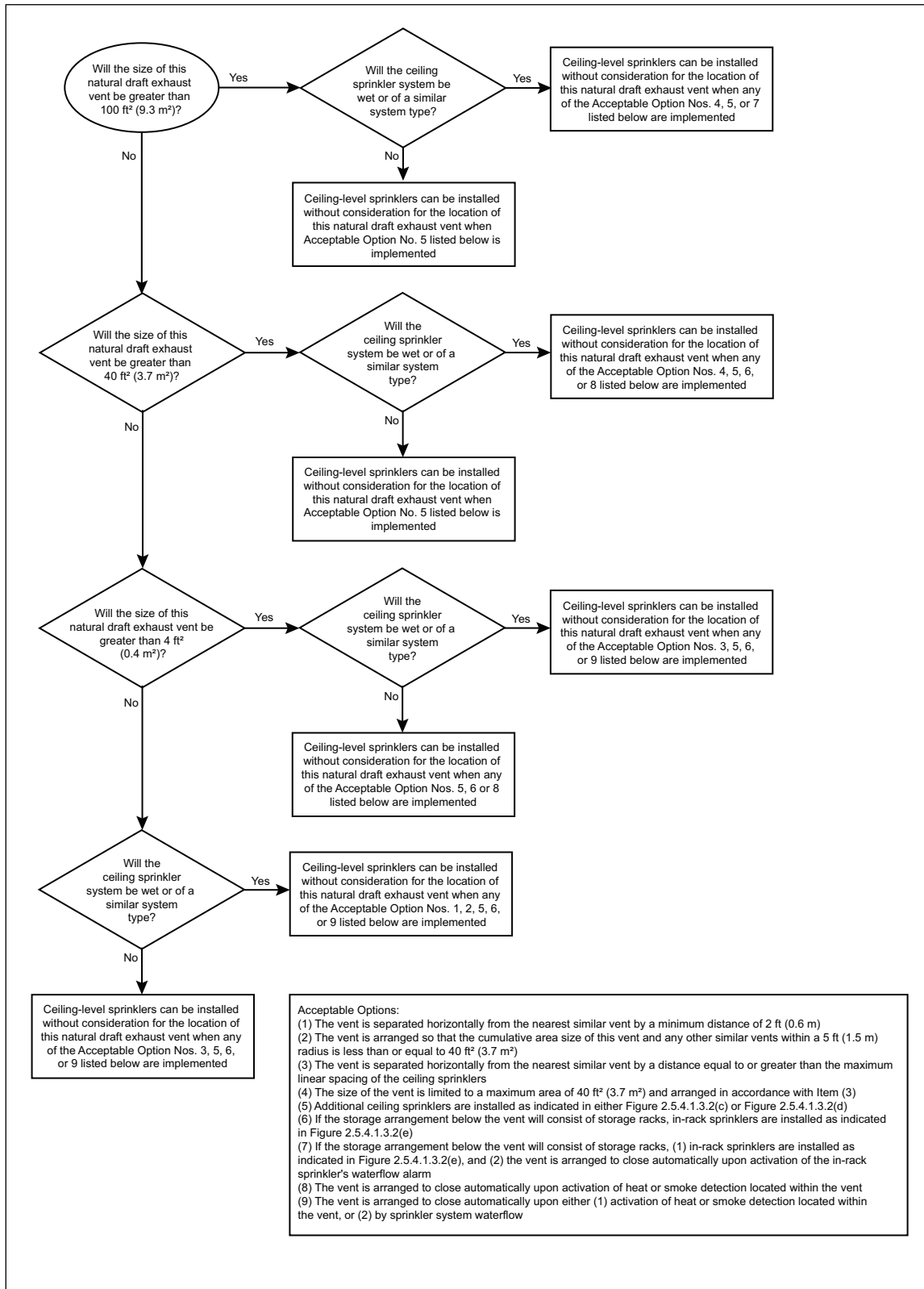

Fig. 2.5.4.1.4. Flowchart for potential recommendations when a natural draft exhaust vent is to be installed over a storage occupancy

## 2.5.4.1.5 Mechanical Exhaust Vents in the Presence of Storage Sprinklers

If a mechanical exhaust vent will be installed at ceiling level over a storage occupancy, use the flowchart in Figure 2.5.4.1.5 to determine if corrective action is needed due to the presence of the mechanical exhaust vent.

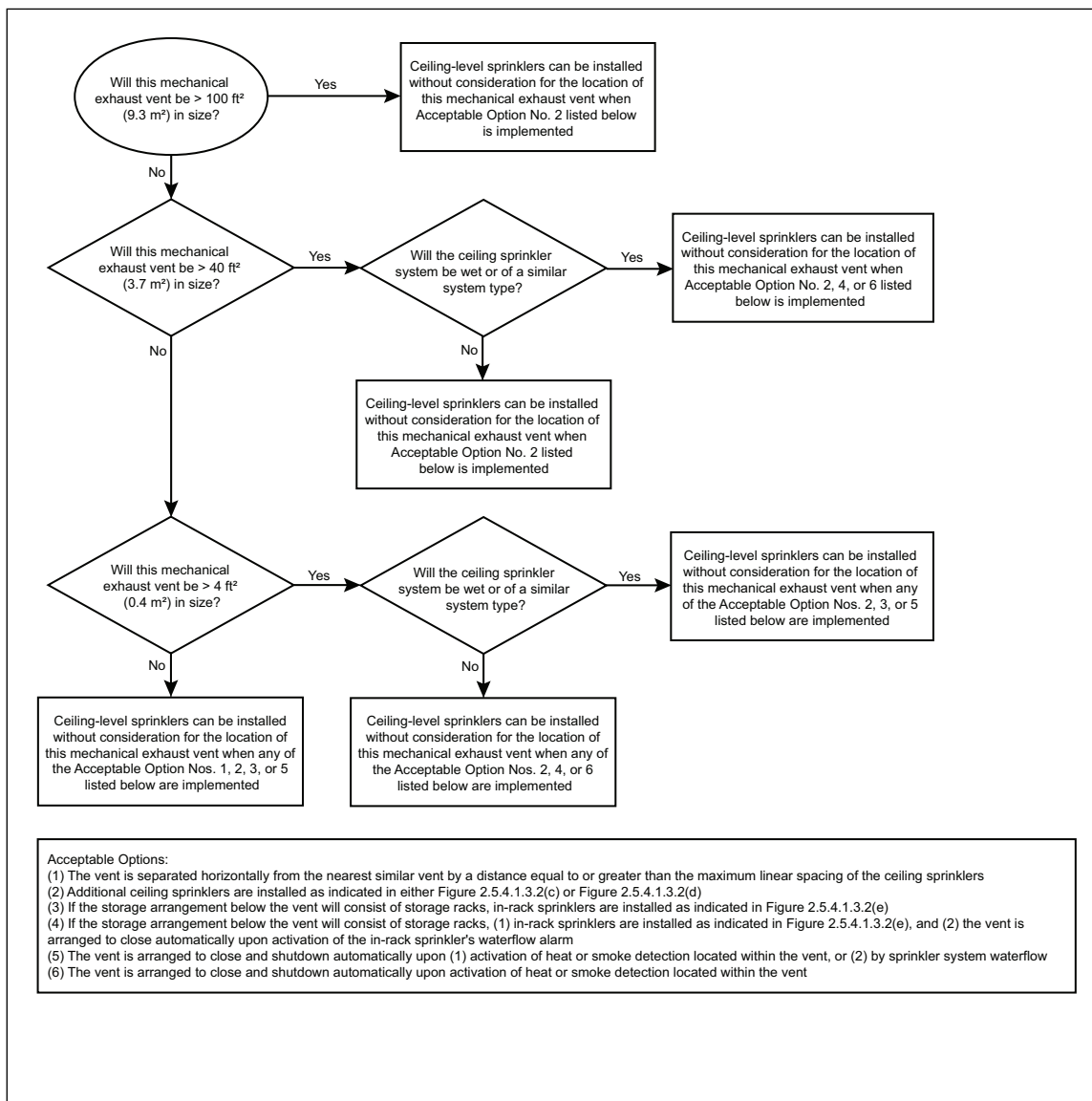

Fig. 2.5.4.1.5. Flowchart for potential recommendations when a mechanical exhaust vent is to be installed over a storage occupancy

## 2.5.4.1.6 Ridge Vents in the Presence of Storage Sprinklers

If a ridge vent will be installed at ceiling level over a storage occupancy, see Figures 2.5.4.1.6(a) through Figure 2.5.4.1.6(d) for acceptable ceiling-level sprinkler arrangements, depending on the width of the ridge vent.

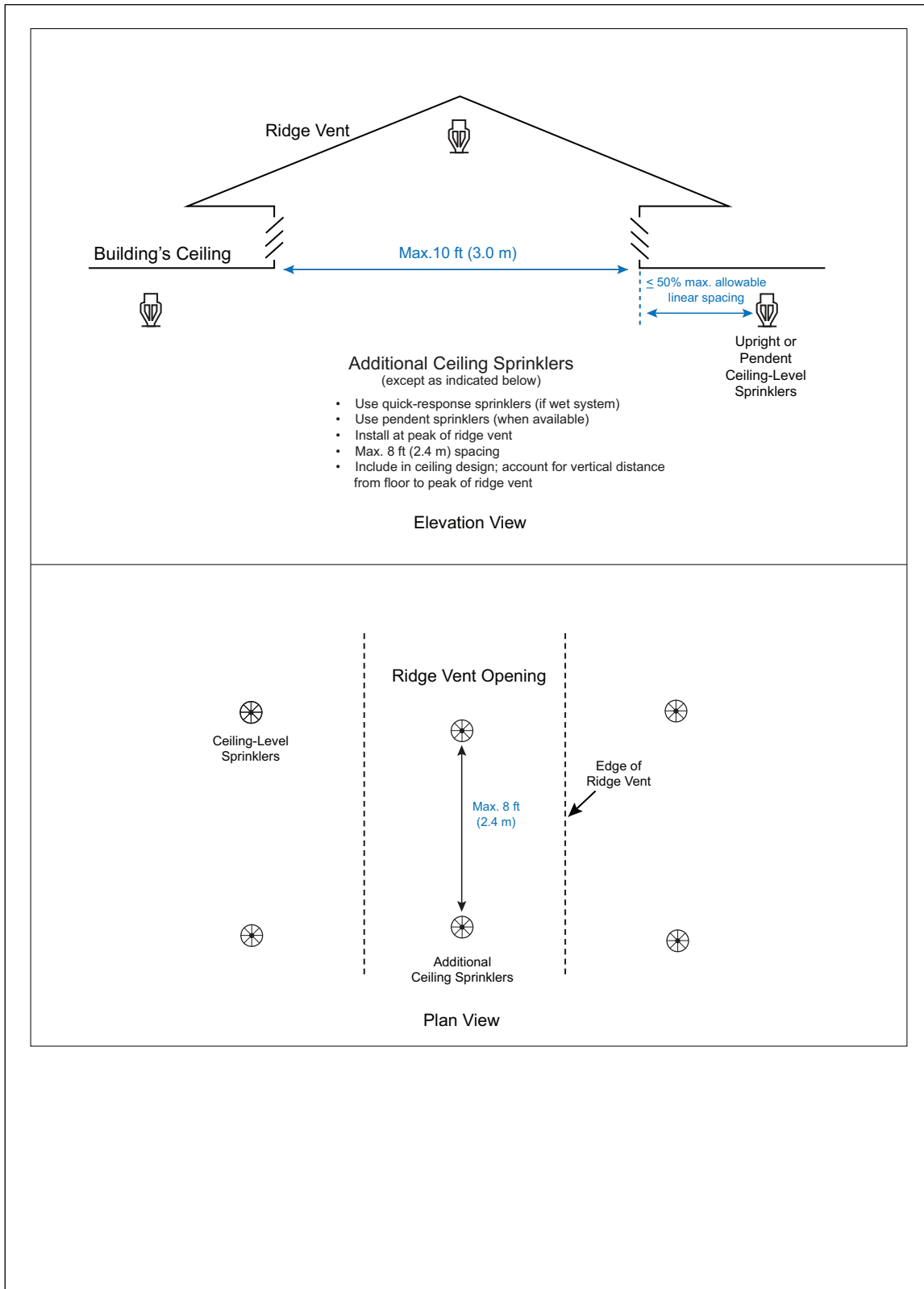

Fig. 2.5.4.1.6(a). Acceptable ceiling-level sprinkler arrangement for the protection of a storage occupancy in the presence of a ridge vent up to 10 ft (3.0 m) wide, using additional ceiling-level sprinklers installed within the ridge vent

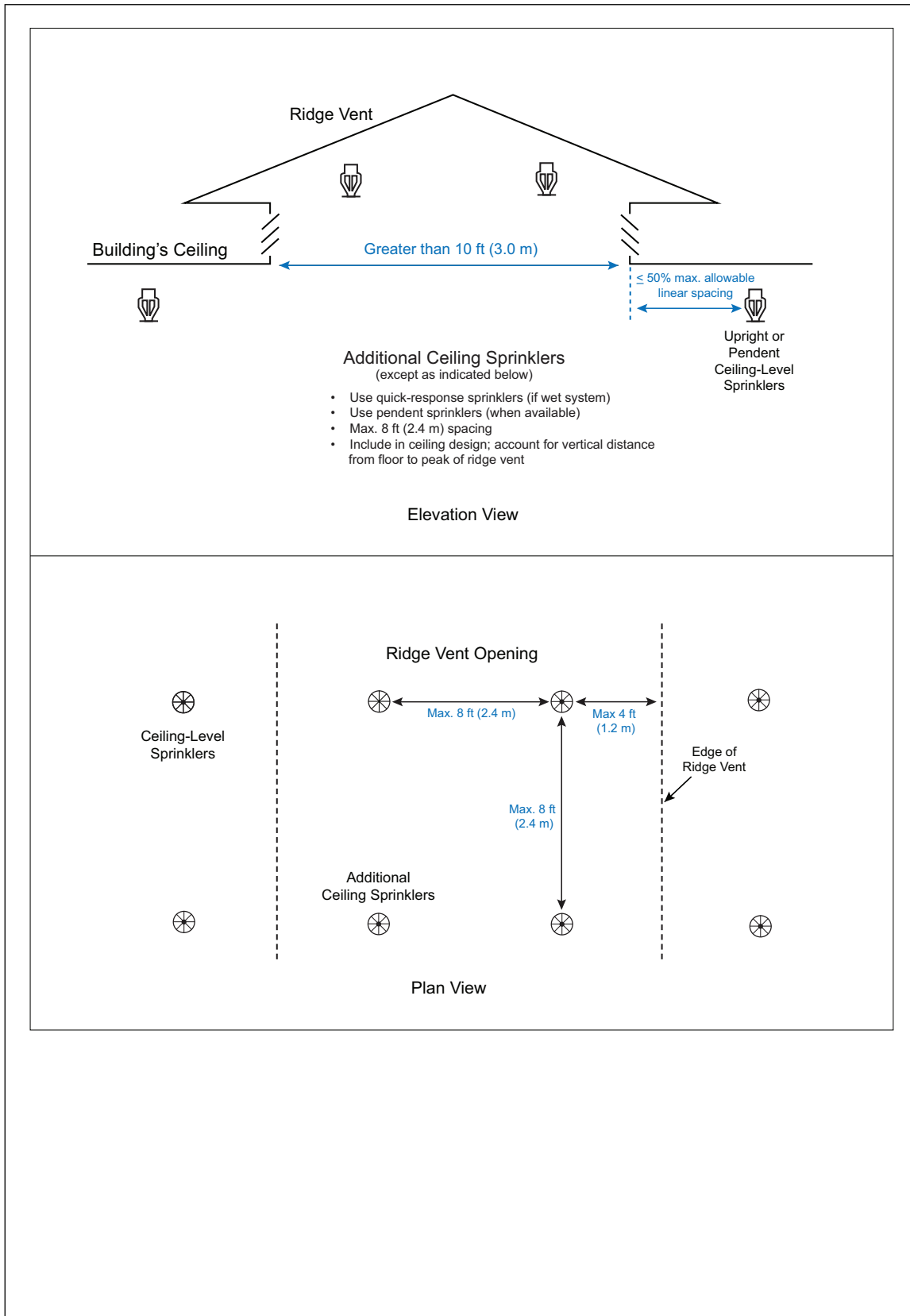

Fig. 2.5.4.1.6(b). Acceptable ceiling-level sprinkler arrangement for the protection of a storage occupancy in the presence of a ridge vent over 10 ft (3.0 m) wide, using additional ceiling-level sprinklers installed within the ridge vent

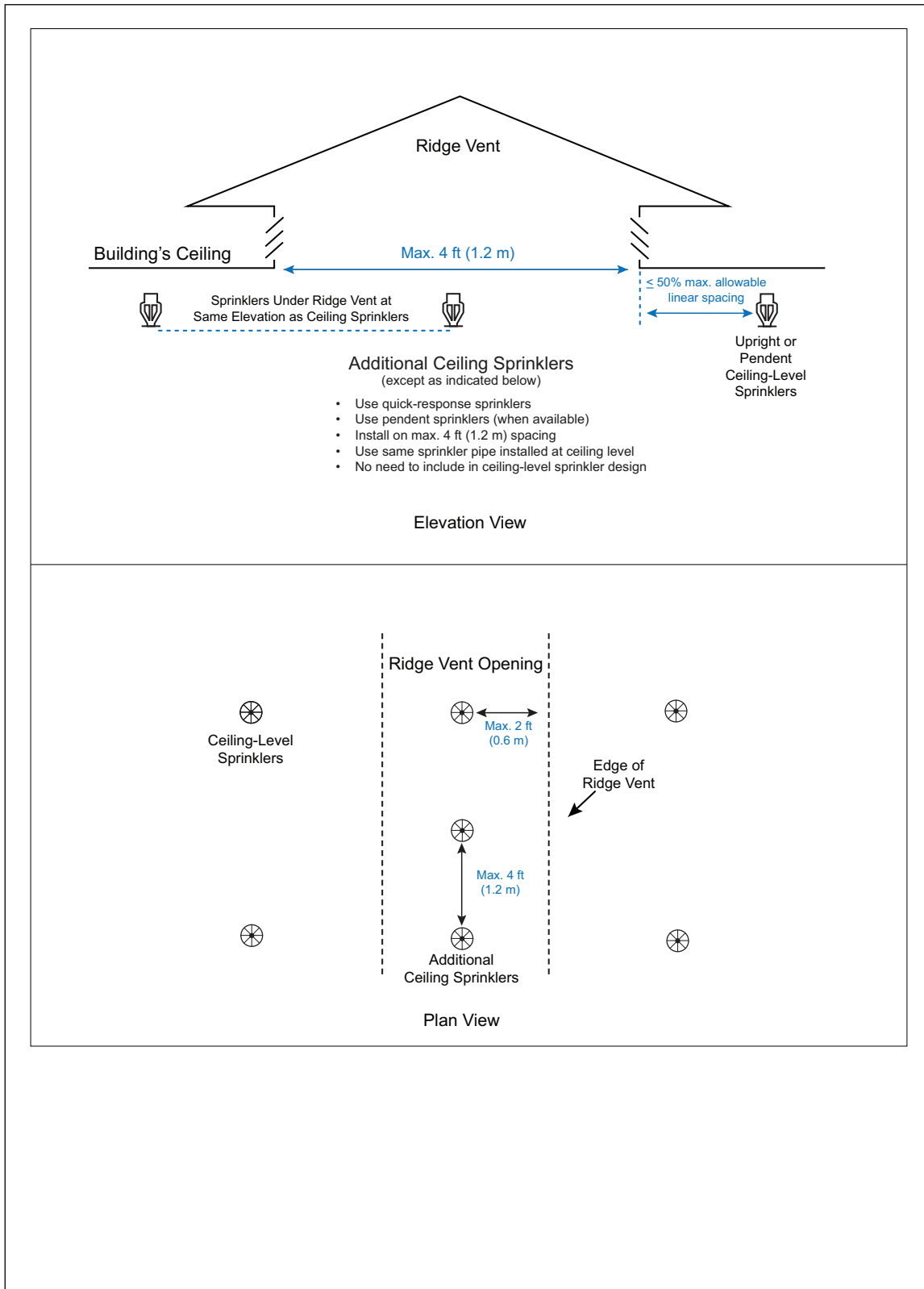

Fig. 2.5.4.1.6(c). Acceptable ceiling-level sprinkler arrangement for the protection of a storage occupancy in the presence of a ridge vent up to 4 ft (1.2 m) wide, using additional quick-response, ceiling-level sprinklers installed below the ridge vent

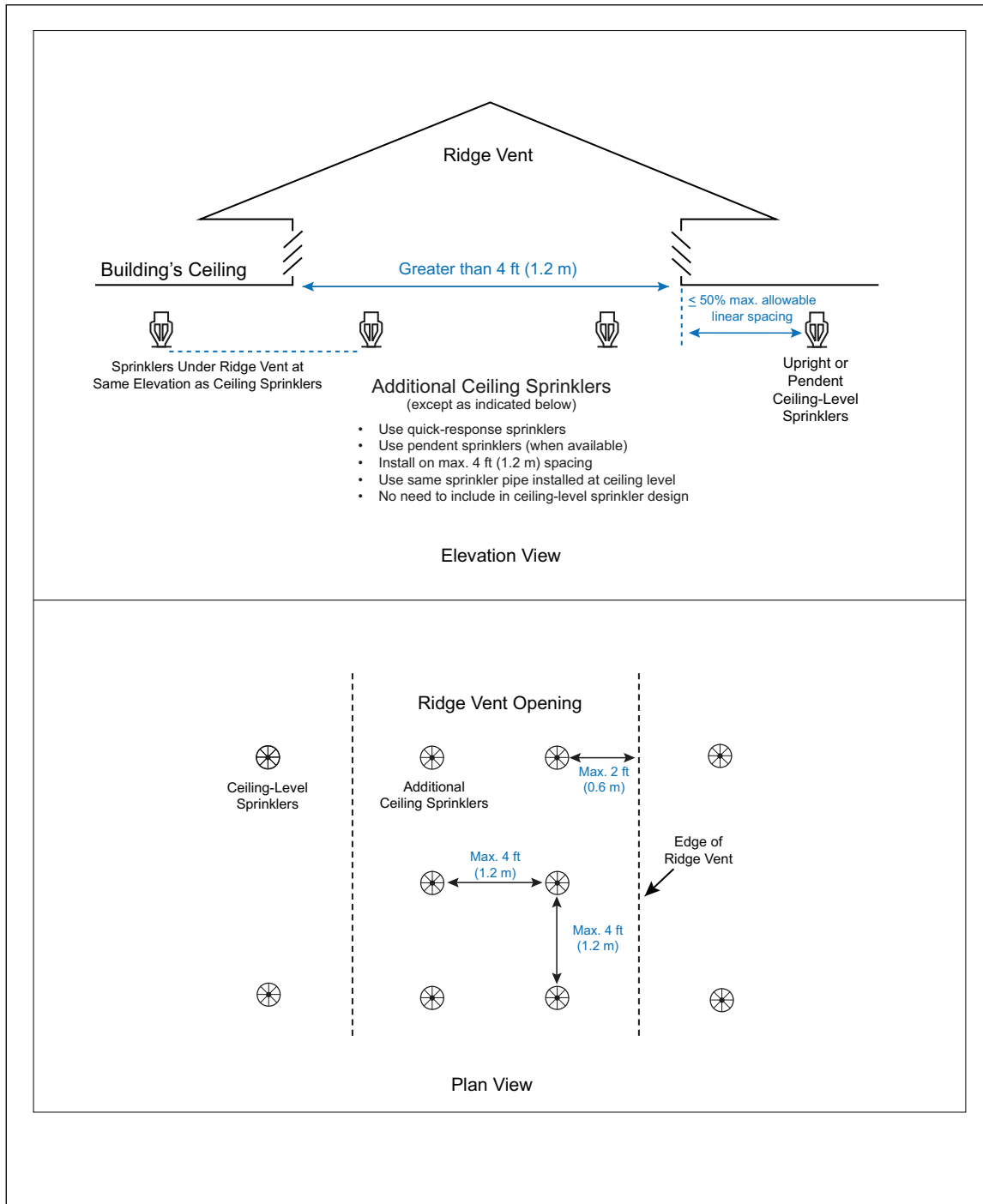

Fig., 2.5.4.1.6(d). Acceptable ceiling-level sprinkler arrangement for the protection of a storage occupancy in the presence of a ridge vent greater than 4 ft (1.2 m) wide using additional quick-response ceiling-level sprinklers installed below the ridge vent

#### 2.5.4.1.7 Skylights in the Presence of Storage Sprinklers

Install ceiling-level sprinklers below skylights, whether glass or plastic, in the same manner as installing under a noncombustible ceiling.

If the skylight is equipped with a gravity heat/smoke vent, see the recommendations in Section 2.5.4.1.3.

If the skylight is elevated above the adjacent ceiling area, see the recommendations in Section 2.5.4.1.8 to determine whether the skylight qualifies as a ceiling pocket. If so, determine whether sprinklers are recommended within the skylight.

### **2.5.4.1.8 Ceiling Pockets in the Presence of Storage Sprinklers**

See the flowchart in Figure 2.5.4.1.8 to determine if sprinklers are recommended within the footprint of a ceiling pocket in addition to being installed under the main lower ceiling of the protected area.

If the flowchart indicates that sprinklers are recommended within the ceiling pocket, install the sprinklers based on the guidelines indicated for the maximum ceiling height of the ceiling pocket. Note that the minimum allowable horizontal distances between sprinklers in the ceiling pocket and those located below the main ceiling can be ignored. However, the maximum allowable horizontal distances between these sprinklers cannot be ignored.

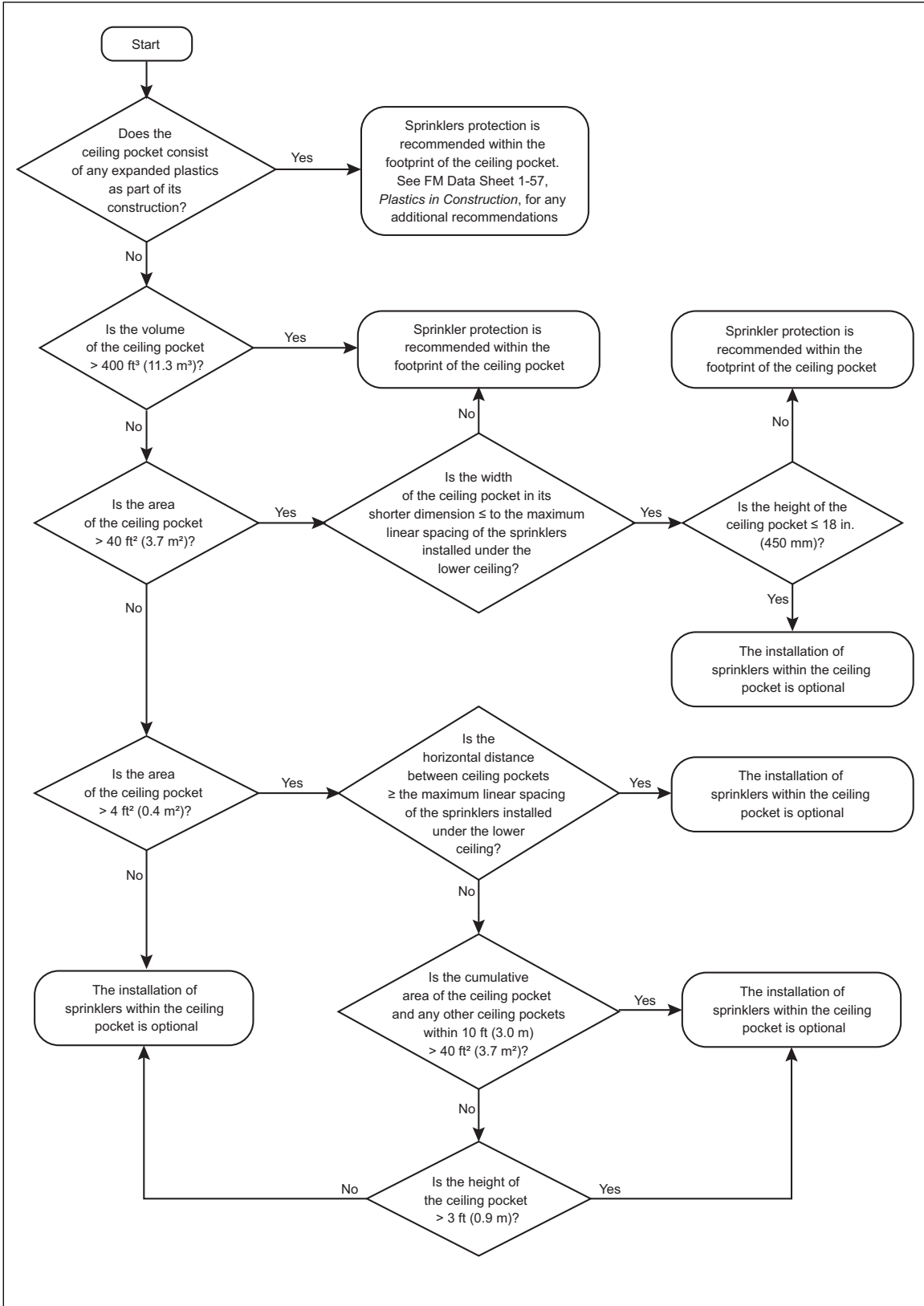

Fig. 2.5.4.1.8. Flowchart to determine if sprinklers are needed within a ceiling pocket of a storage area protected by pendent or upright sprinklers

### 2.5.4.1.9 Airflow Velocities Below Storage Ceiling Sprinklers

2.5.4.1.9.1 For storage-type occupancies, arrange any airflow between the top of storage and a horizontal plane located at the ceiling-level sprinklers (such as airflow from HVLS fans demonstrated in Figure 2.5.4.1.9.1(a), or HVAC equipment demonstrated in Figure 2.5.4.1.9.1(b)) so that the airflow velocity does not exceed 5 ft/sec (1.5 m/sec). If the airflow cannot be limited to a maximum velocity of 5 ft/sec (1.5 m/sec), see the flowchart in Figure 2.5.4.1.9.1 for acceptable options.

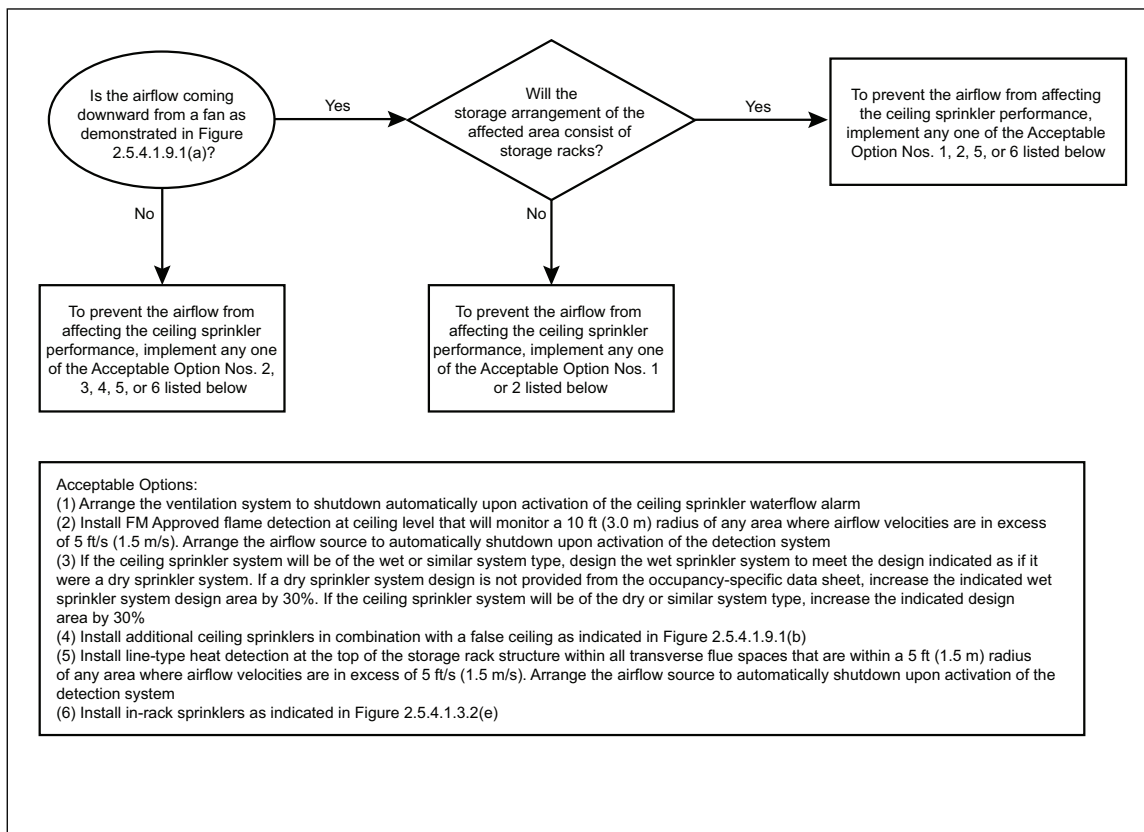

Fig. 2.5.4.1.9.1. Flowchart for acceptable protection options when airflow velocities exceed 5 ft/sec (1.5 m/sec) at or below ceiling-level sprinklers protecting a storage occupancy

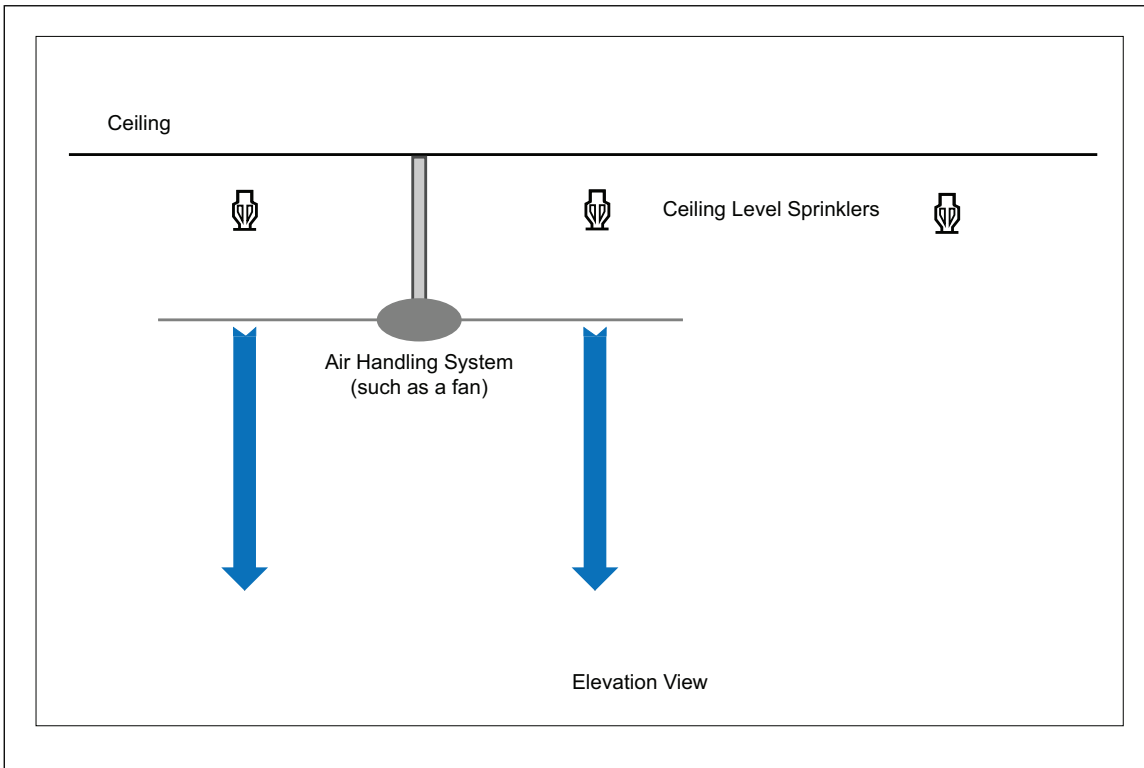

Fig. 2.5.4.1.9.1(a). Example of airflow velocities created by ceiling-mounted equipment, such as HVLS type fans

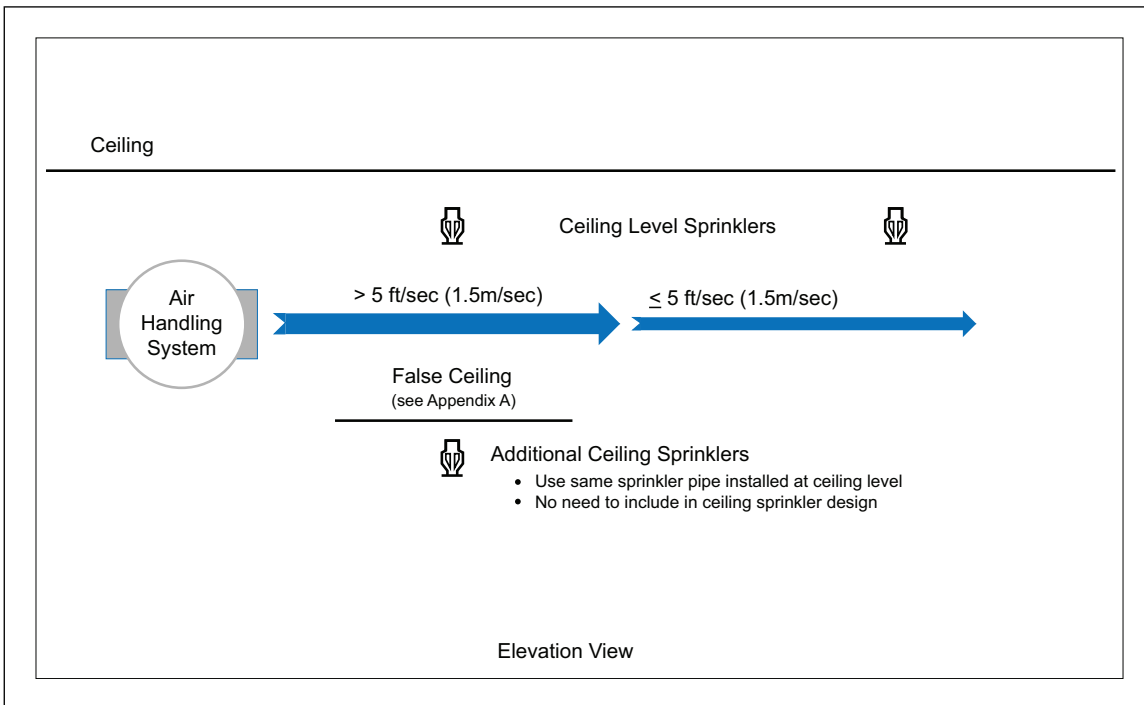

Fig. 2.5.4.1.9.1(b). Acceptable arrangement of additional ceiling-level sprinklers in areas where airflow velocities exceed 5 ft/sec (1.5 m/sec)

2.5.4.1.9.2 Where a flat, continuous, false ceiling is to be installed as shown in Figure 2.5.4.1.9.1(b), use minimum 22-gauge (0.7 mm) sheet metal or similar noncombustible material for the false ceiling; and secure

it so that it can resist a minimum uplift velocity pressure of 3 lb/ft<sup>2</sup> (14.6 kg/m<sup>2</sup>). A less desirable but acceptable alternative to noncombustible materials includes minimum 3/8 in. (10 mm) plywood (or similar material).

### 2.5.4.2 Determining Obstructed or Unobstructed Ceiling Construction

2.5.4.2.1 See the flowchart in Figure 2.5.4.2.1 to determine if the ceiling construction qualifies as either unobstructed or obstructed for the installation of Storage sprinklers. Note that a solid ceiling structural member is one where its cross-sectional area in a vertical plane is less than 70% open.

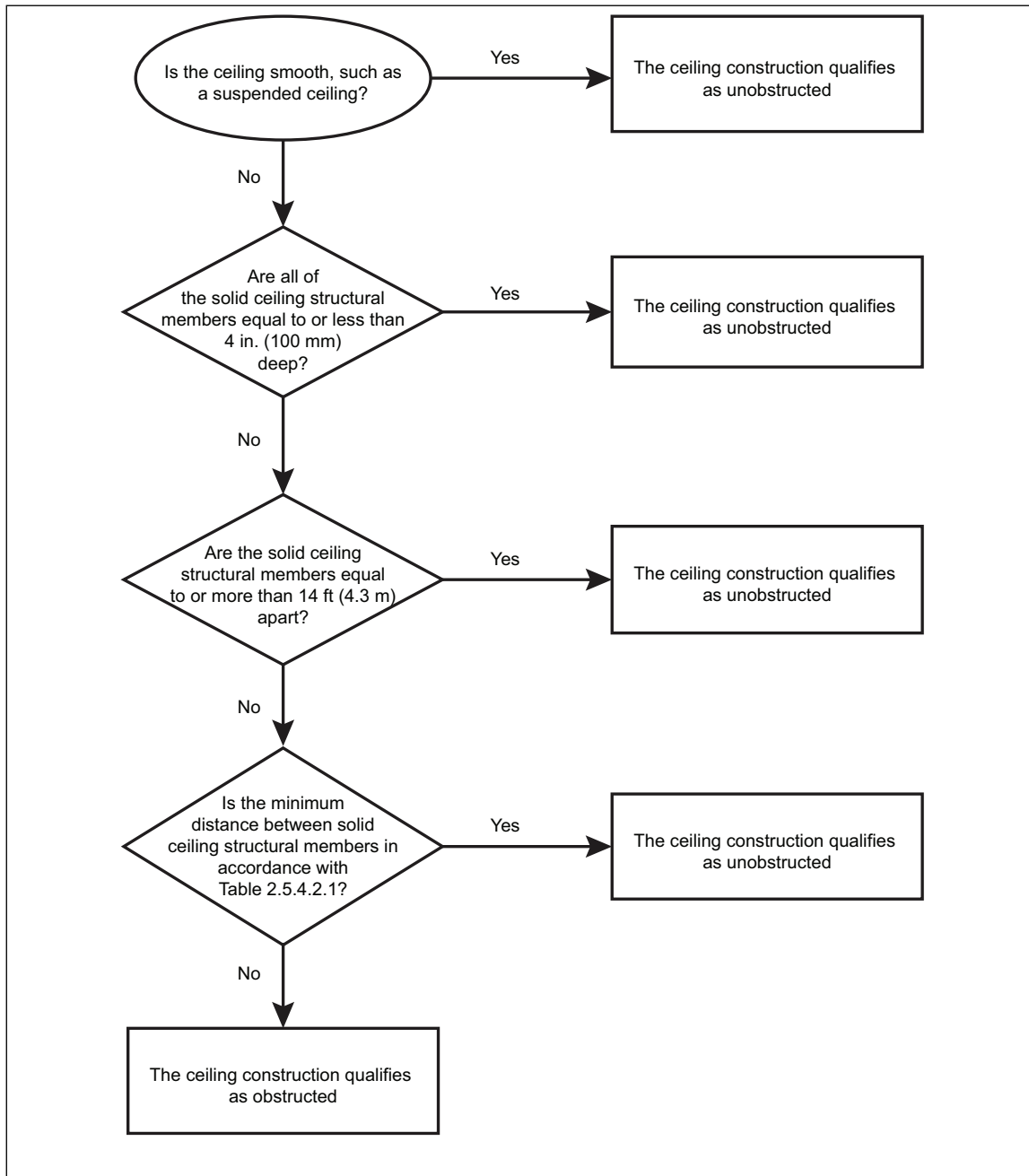

Fig. 2.5.4.2.1. Flowchart for determining ceiling construction type for Storage sprinklers

Table 2.5.4.2.1. Determining Ceiling Construction Type When Solid Structural Members Deeper than 4 in. (100 mm) Are Present

Maximum Ceiling Height, ft (m)	Sprinkler Coverage Type	Minimum Distance Required Between Solid Ceiling Structural Members to Qualify as Unobstructed, ft (m)
≤ 30 (9.1)	Standard-Coverage	12 (3.7)
	Extended-Coverage	14 (4.3)
> 30 (9.1)	Standard-Coverage	10 (3.0)
	Extended-Coverage	14 (4.3)

2.5.4.2.2 Install Storage sprinklers in accordance with the horizontal and vertical positioning recommendations indicated in Section 2.5.4.3 if the flowchart in Figure 2.5.4.2.1 qualifies the ceiling construction type as unobstructed.

2.5.4.2.3 Install Storage sprinklers in accordance with the horizontal and vertical positioning recommendations indicated in Section 2.5.4.4 if the flowchart in Figure 2.5.4.2.1 qualifies the ceiling construction type as obstructed.

### 2.5.4.3 Horizontal and Vertical Positioning of Storage Sprinklers Under Unobstructed Ceiling Construction

#### 2.5.4.3.1 Horizontal Linear and Area Spacing of Storage Sprinklers

2.5.4.3.1.1 If the occupancy-specific data sheet does not provide recommendations regarding the ceiling sprinkler spacing, install Storage sprinklers under unobstructed ceiling construction in accordance with Table 2.5.4.3.1.1.

Table 2.5.4.3.1.1. Spacing of Ceiling-Level Storage Sprinklers Under Unobstructed Ceiling Construction

Ceiling Height, ft (m)	Sprinkler K-Factor	Sprinkler Orientation	Sprinkler RTI Response	Sprinkler Linear Spacing, ft (m)		Sprinkler Area Spacing, ft <sup>2</sup> (m <sup>2</sup> )	
				Min.	Max.	Min.	Max.
Up to 30 (9.0)	11.2 (160), 14.0 (200), 16.8 (240), 19.6 (280), 22.4 (320), 25.2 (360), or 33.6 (480)	Pendent or Upright	Quick or Standard	8 (2.4)	12 (3.7)	64 (6.0)	100 (9.3)
	25.2EC (360EC)	Pendent or Upright	Quick	10 (3.0)	14 (4.3)	100 (9.3)	196 (18.2)
Over 30 (9.0)	11.2 (160), 14.0 (200), 16.8 (240), 19.6 (280), 22.4 (320), 25.2 (360), or 33.6 (480)	Pendent or Upright	Quick or Standard	8 (2.4)	10 (3.0)	64 (6.0)	100 (9.3)
	25.2EC (360EC)	Pendent or Upright	Quick	10 (3.0)	14 (4.3)	100 (9.3)	196 (18.2)

2.5.4.3.1.2 Measure the linear distance between sprinklers along the slope of the ceiling, not on the viewpoint from floor level.

#### 2.5.4.3.2 Horizontal Distance from Walls and Corners to Storage Sprinklers

Install Storage sprinklers horizontally from walls, measured perpendicular to the wall, and wall corners as shown in Figure 2.5.4.3.2.

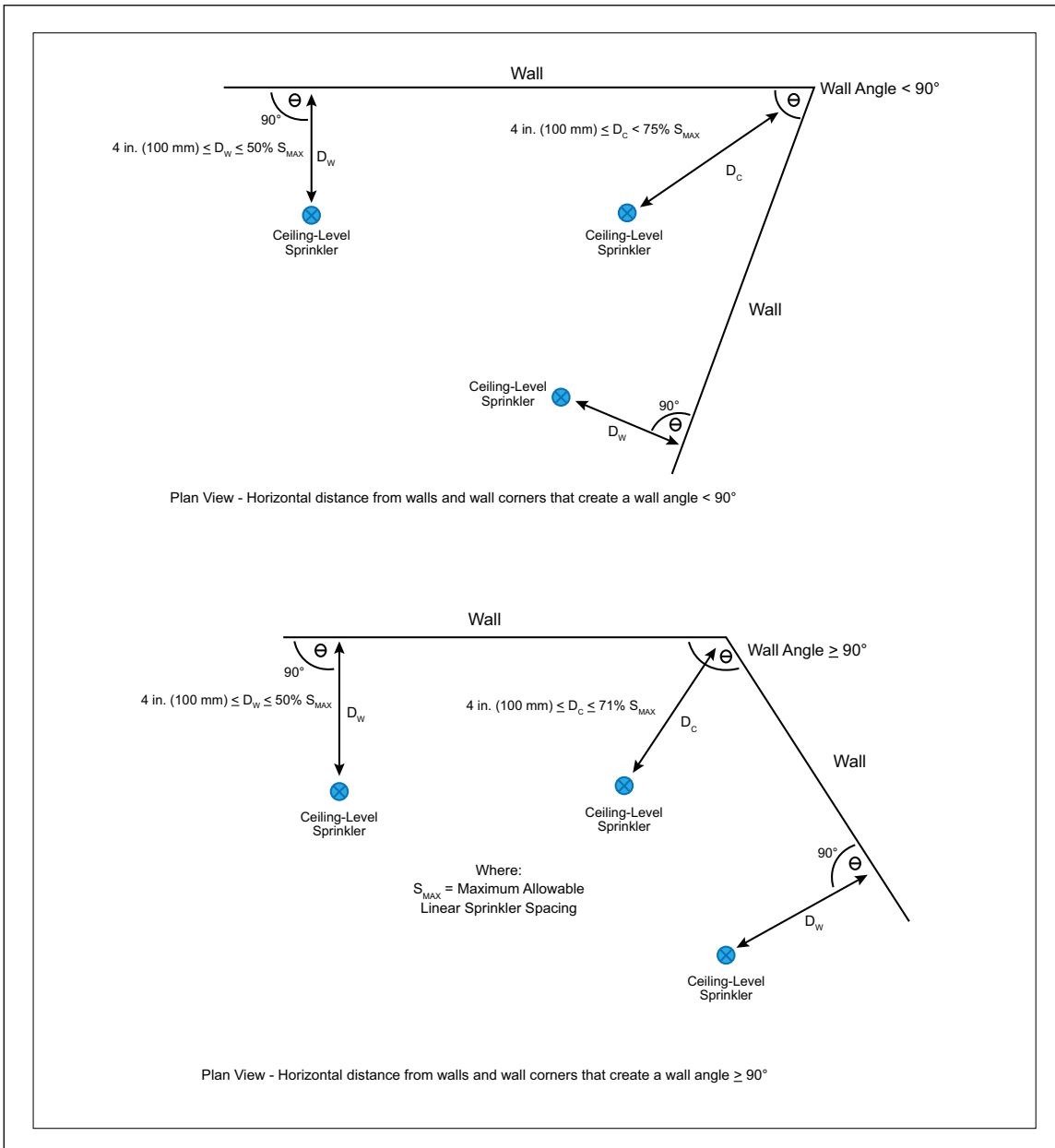

Fig. 2.5.4.3.2. Horizontal distances from walls and wall corners to Storage sprinklers

2.5.4.3.3 Vertical Location of Storage Sprinklers Under Unobstructed Construction

2.5.4.3.3.1 The vertical distance between a sprinkler (centerline of the sprinkler's thermal element) and the underside of the ceiling is measured perpendicular to the ceiling as shown in Figure 2.5.4.3.3.1.

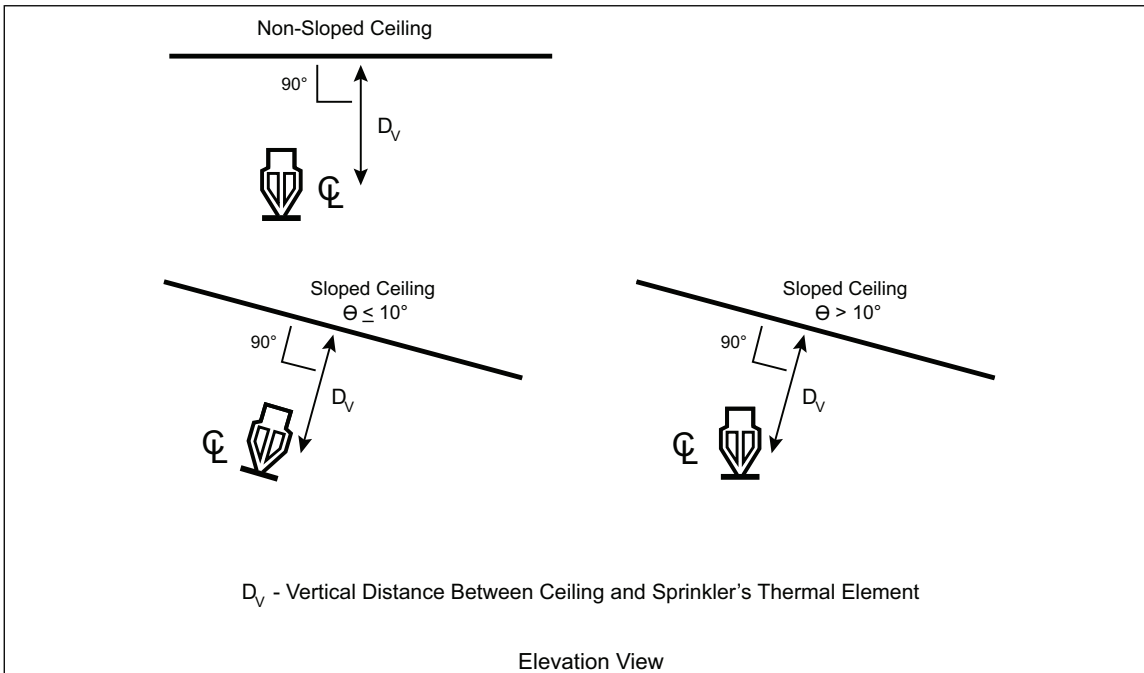

Fig. 2.5.4.3.3.1. Measuring vertical distance between Storage sprinkler's thermal element and underside of ceiling

2.5.4.3.3.2 If a ceiling is corrugated, see Figure 2.5.4.3.3.2 to determine how to measure the vertical distance from the sprinkler's thermal element to the underside of the ceiling.

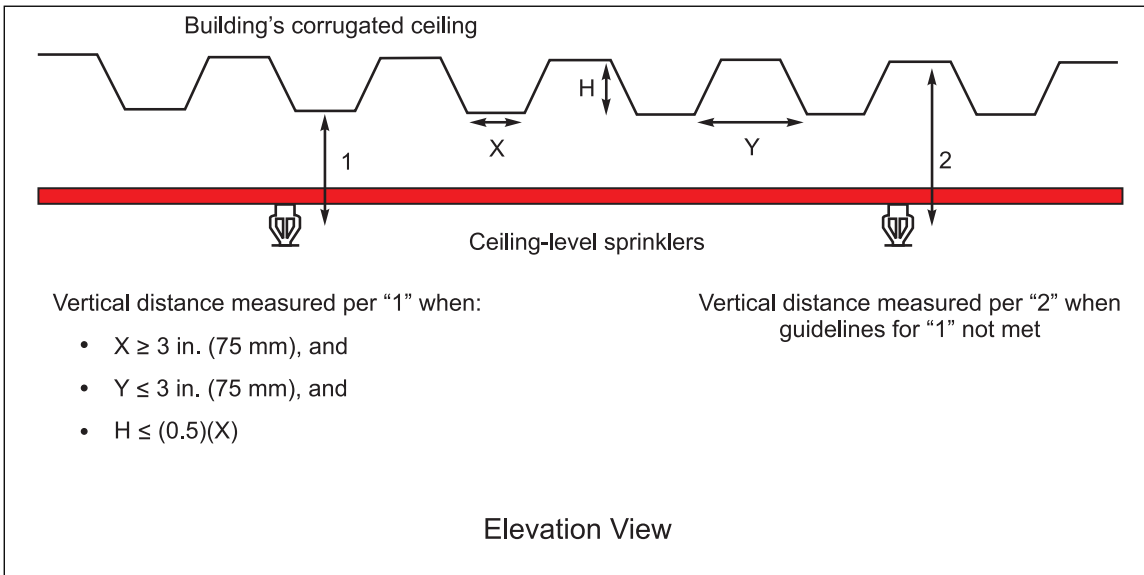

Fig. 2.5.4.3.3.2. How to measure the vertical distance between the thermal element of Storage sprinklers and the underside of a corrugated ceiling

2.5.4.3.3.3 If a vinyl-type canvas support, or similar type of insulating system (a reflective ceiling does not apply), is provided below the underside of the ceiling, the vertical distance between the sprinkler (centerline of the sprinkler's thermal element) and the ceiling is measured as shown in Figure 2.5.4.3.3.3.

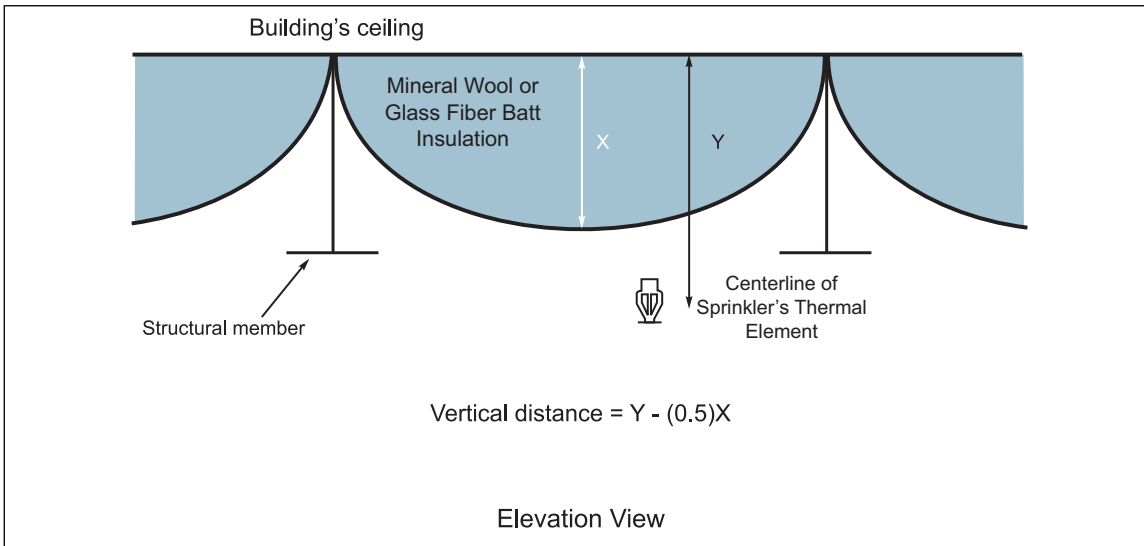

Fig. 2.5.4.3.3.3. Vertical distance between ceiling and centerline of sprinkler's thermal element in the presence of mineral wool or glass fiber batt insulation

2.5.4.3.3.4 Unless indicated otherwise by the relevant occupancy-specific data sheet, install the centerline of Storage sprinklers thermal elements vertically below the underside of the ceiling as shown in Figure 2.5.4.3.3.4. See Table 2.5.4.3.1.1 to determine which sprinklers are allowed for the indicated ceiling height.

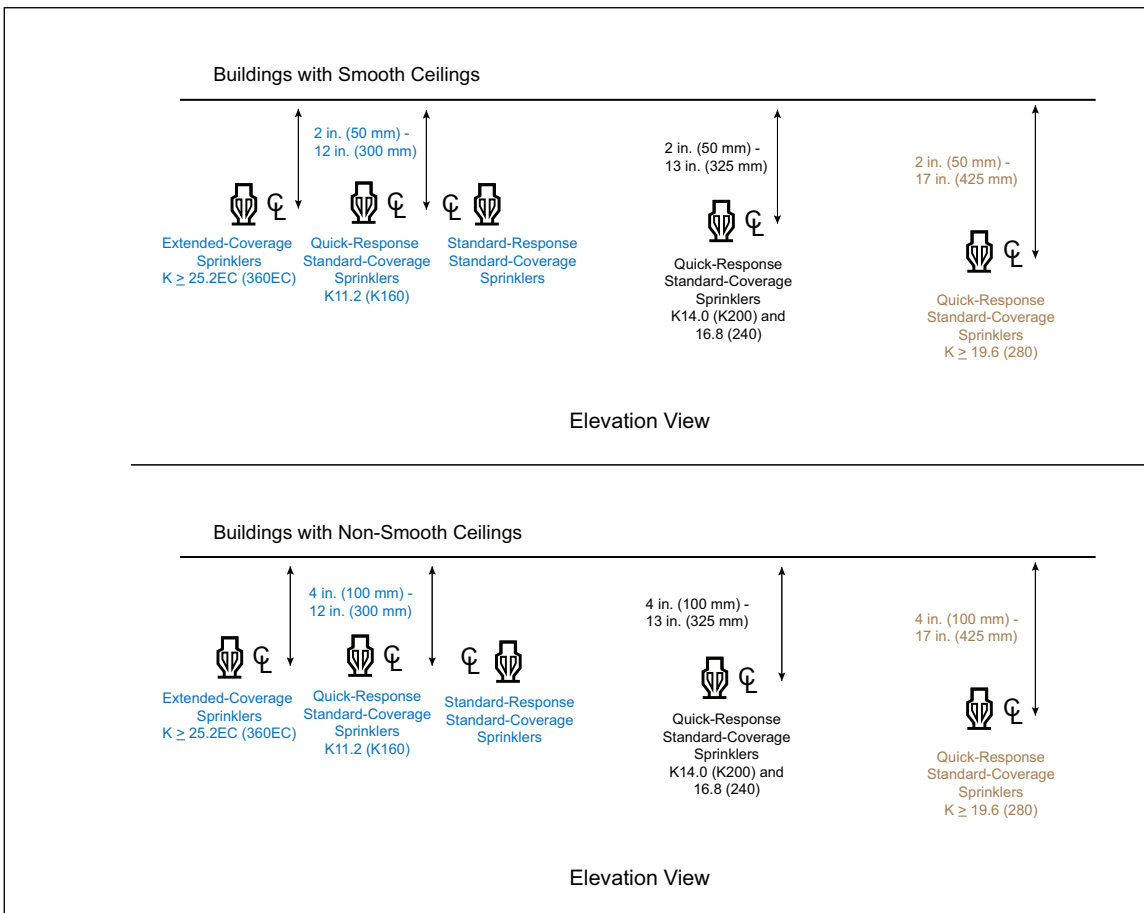

Fig. 2.5.4.3.3.4. Vertical location of Storage sprinklers under unobstructed ceiling construction for various ceiling heights

**2.5.4.3.4 Impact of Ceiling Slope on the Installation of Storage Sprinklers Under Unobstructed Ceiling Construction**

2.5.4.3.4.1 See the flowchart in Figure 2.5.4.3.4.1(a) for guidelines involving the impact of ceiling slope in the presence of Storage sprinklers. For ceilings that are not straight, base the ceiling slope using a tangent line at the point of the ceiling being analyzed (point of tangency).

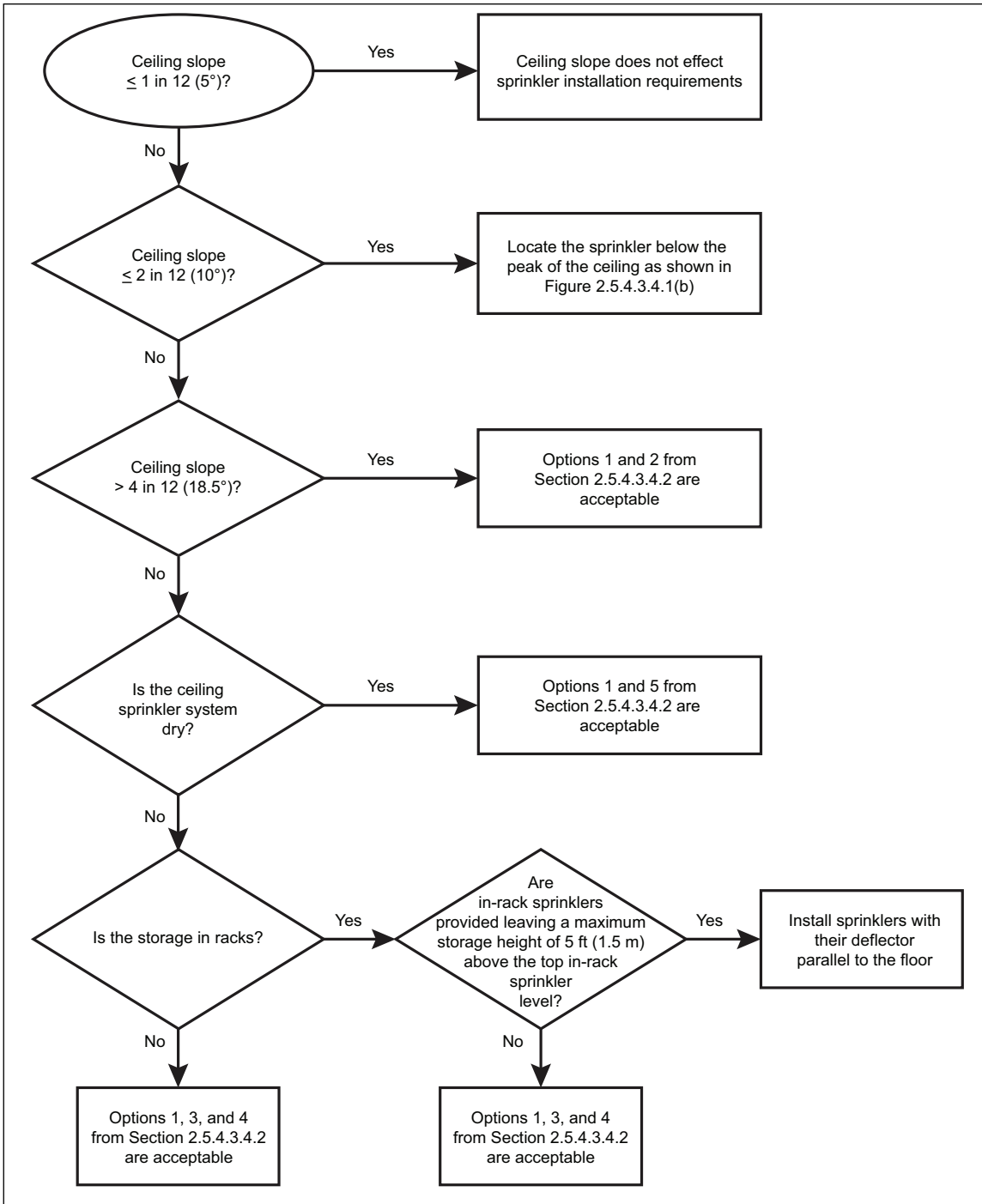

Fig. 2.5.4.3.4.1(a). Guidelines involving ceiling slope with Storage sprinklers under unobstructed ceiling construction

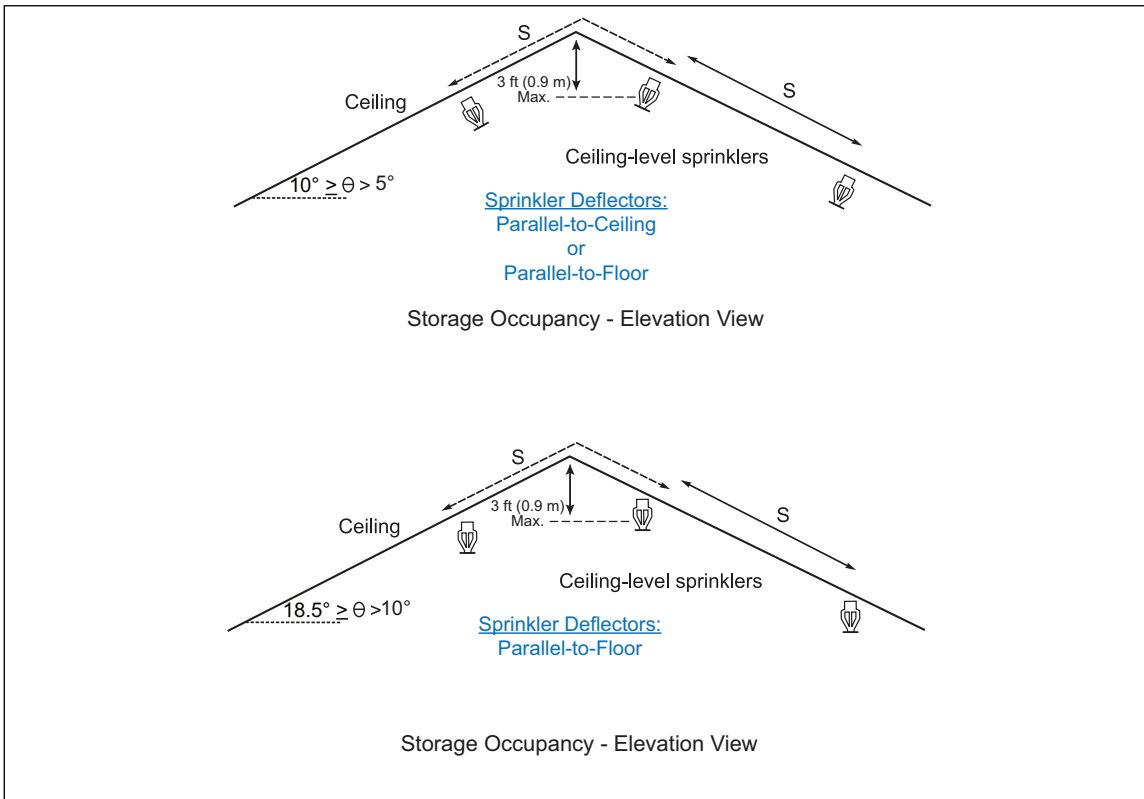

Fig. 2.5.4.3.4.1(b). Location and arrangement of Storage sprinklers near ceiling peak when slope exceeds (a) 1 in 12 (5°), and (b) 2 in 12 (10°)

2.5.4.3.4.2 The acceptable options from Figure 2.5.4.3.4.1(a) are as follows:

Option 1: Install a flat, continuous, false ceiling with additional ceiling sprinklers below the false ceiling as shown in Figure 2.5.4.3.4.2.

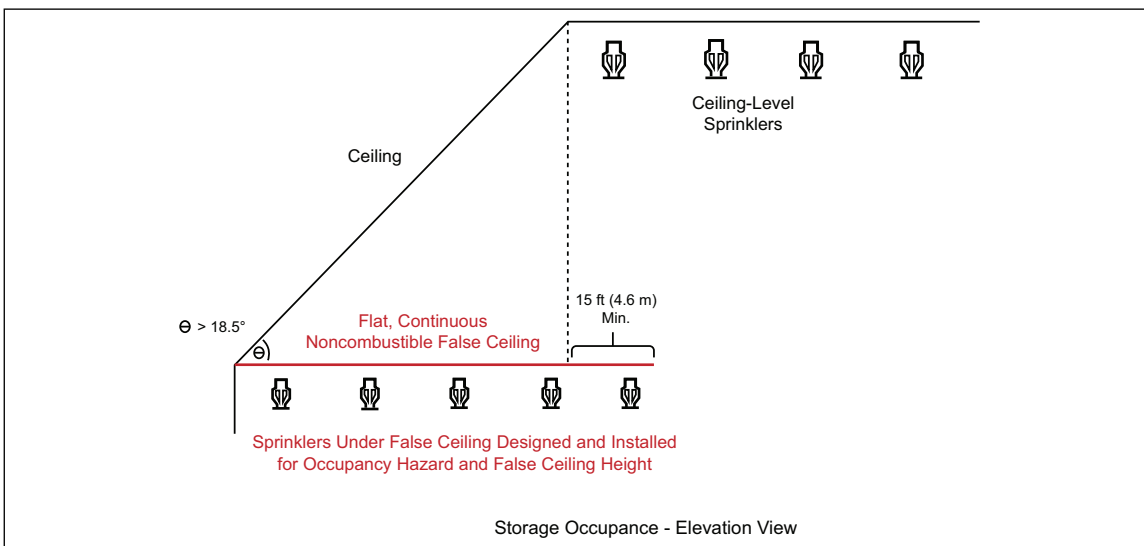

Fig. 2.5.4.3.4.2. Option 1 per Figure 2.5.4.3.4.1(a) involving the installation of a flat, continuous, false ceiling with additional ceiling sprinklers

Option 2: If the ceiling sprinkler system is wet-pipe and the storage is maintained within racks, provide in-rack sprinklers in accordance with the occupancy-specific data sheet such that there is no storage left above the top level of in-rack sprinklers.

Option 3: Locate the ceiling-level sprinklers below the peak of the ceiling as shown in Figure 2.5.4.3.4.1(b) with their deflectors oriented parallel to the floor. In addition, increase the ceiling sprinkler design area obtained from the occupancy-specific data sheet by 50%.

Option 4: Locate the ceiling-level sprinklers below the peak of the ceiling as shown in Figure 2.5.4.3.4.1(b) with their deflectors oriented parallel to the floor. In addition, except for the sprinklers located closest to the ceiling peak, which are installed on their normal spacing, install the ceiling-level sprinklers on 4 ft x 4 ft (1.2 m x 1.2 m) spacing.

Option 5: If the ceiling sprinkler system is dry-pipe and the storage is maintained within racks, provide in-rack sprinklers in accordance with the occupancy-specific data sheet such that there is no more than 5 ft (1.5 m) of storage left above the top level of in-rack sprinklers. In addition, increase the ceiling sprinkler design area obtained from the occupancy-specific data sheet by 50%. Locate the ceiling-level sprinklers below the peak of the ceiling as shown in Figure 2.5.4.3.4.1(b) with their deflectors oriented parallel to the floor.

2.5.4.3.4.3 Where a flat, continuous, false ceiling is to be installed as shown in Figure 2.5.4.3.4.2, use minimum 22-gauge (0.7 mm) sheet metal or similar noncombustible material for the false ceiling; and secure it so that it can resist a minimum uplift velocity pressure of 3 lb/ft<sup>2</sup> (14.6 kg/m<sup>2</sup>). A less desirable but acceptable alternative to noncombustible materials includes minimum 3/8 in. (10 mm) plywood (or similar material).

### 2.5.4.4 Horizontal and Vertical Positioning of Storage Sprinklers Under Obstructed Ceiling Construction

2.5.4.4.1 Measure the linear distance between sprinklers along the slope of the ceiling, not on the viewpoint from floor level.

2.5.4.4.2 See the flowchart in Figure 2.5.4.4.2 to determine the recommended horizontal and vertical location of the ceiling sprinklers.

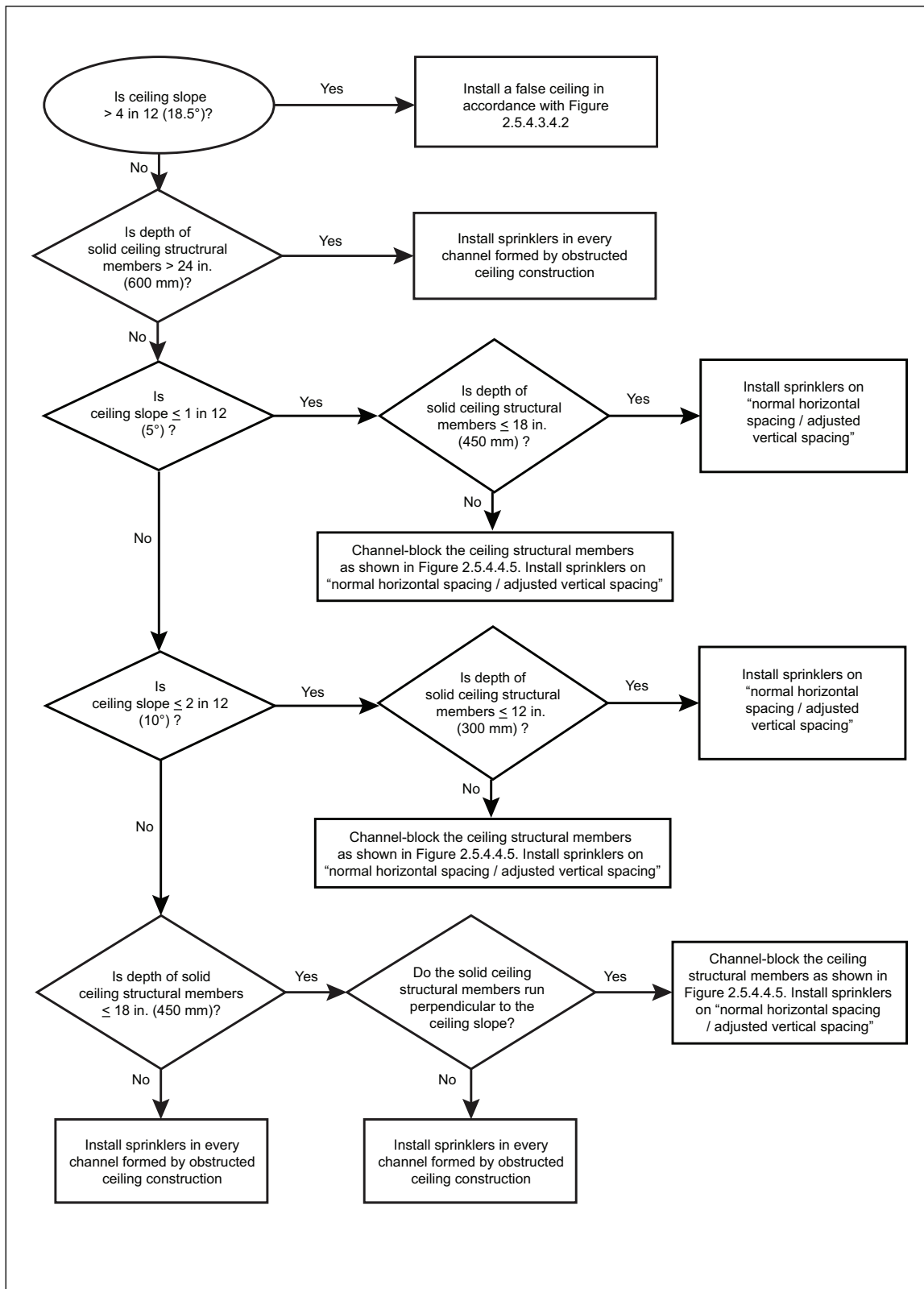

Fig. 2.5.4.4.2. Determining the horizontal and vertical location of Storage sprinklers in the presence of obstructed ceiling construction

2.5.4.4.3 If the flowchart in Figure 2.5.4.4.2 indicates to install sprinklers in every channel formed by obstructed ceiling construction:

A. Horizontal spacing: Determine the minimum and maximum allowable horizontal spacing of the sprinklers within each channel based on the linear spacings indicated in the occupancy-specific data sheet. If spacing is not provided, then use those indicated in Table 2.5.4.3.1.1. If the ceiling structural members have openings, stagger sprinklers horizontally between channels, as needed, to meet the minimum recommended linear spacing requirements.

B. Vertical spacing: Determine the minimum and maximum allowable vertical location of the sprinklers below the ceiling within each channel based on the distances indicated in Section 2.5.4.3.3.

C. Sprinkler system design: If sprinklers are installed in every channel formed by obstructed ceiling construction and the ceiling sprinkler system design is based on density / demand area, using the following steps for establishing the demand area and the design flow at the most remote sprinkler:

1. If not specified by the occupancy-specific data sheet, the number of sprinklers operating per branch line is determined by taking the square root of the demand area, multiplying it by the applicable shape factor and then dividing it by the linear spacing of the sprinklers being installed within the channel created by the ceiling structural members. Use normal rounding methods if this calculation does not result in a whole number.

2. The number of sprinklers to include in the hydraulic analysis of the ceiling sprinkler system is determined by taking the indicated required demand area and dividing it by the maximum allowable area spacing of the ceiling sprinkler being installed. Use normal rounding methods if this calculation does not result in a whole number.

3. The minimum required flow at the most remote ceiling sprinkler is determined by taking the indicated required density and multiplying it by the maximum allowable area spacing of the ceiling sprinkler being installed.

2.5.4.4.4 If the flowchart in Figure 2.5.4.4.2 indicates to install sprinklers on normal horizontal spacing/ adjusted vertical spacing, install the sprinklers below the underside of the ceiling structural members as follows:

A. Horizontal spacing: Determine the minimum and maximum allowable horizontal spacing of the sprinklers based on the linear and area spacings indicated in the occupancy-specific data sheet. If spacing is not provided, then use those indicated in Table 2.5.4.3.1.1.

B. Vertical spacing: Determine the minimum and maximum allowable vertical location of the sprinklers below the ceiling based on the distances indicated in Section 2.5.4.3.3. However, if the depth of the solid structural members prevents the guidelines from Section 2.5.4.3.3 to be implemented, locate the thermal element of the sprinklers on a plane not exceeding 6 in. (150 mm) below the underside of the solid ceiling structural members as demonstrated in Figure 2.5.4.4.4.

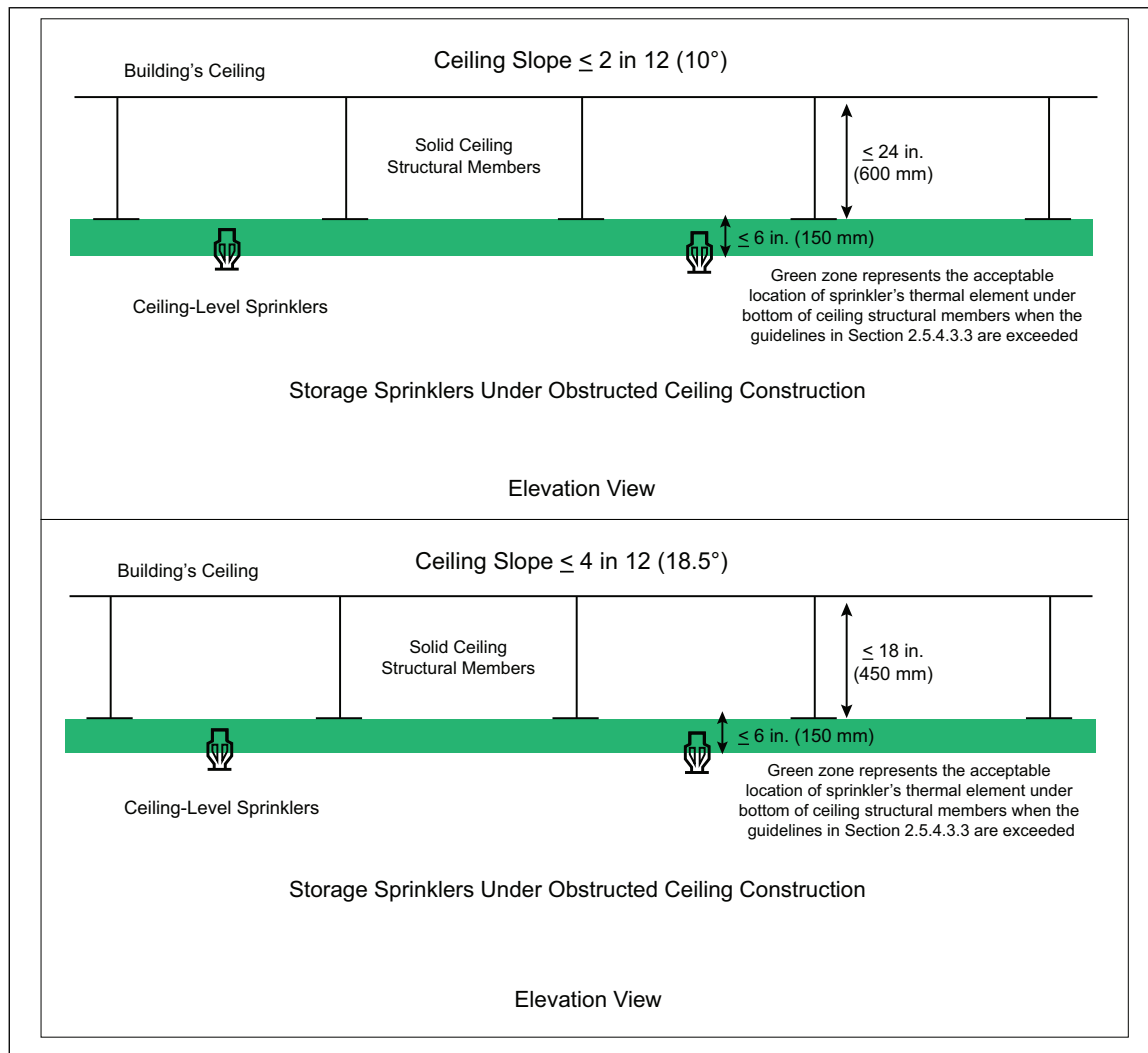

Fig. 2.5.4.4.4. Vertical location of Storage sprinklers under obstructed ceiling construction for ceiling slopes of (a) up to 2 in 12 ( $10^\circ$ ), and (b) up to 4 in 12 ( $18.5^\circ$ )

2.5.4.4.5 If the flowchart in Figure 2.5.4.4.2 indicates to channel-block the ceiling structural members and install sprinklers on normal horizontal spacing/adjusted vertical spacing, install the sprinklers below the underside of the ceiling structural members as follows:

A. Horizontal spacing: Determine the minimum and maximum allowable horizontal spacing of the sprinklers based on the linear and area spacings indicated in the occupancy-specific data sheet. If spacing is not provided, then use those indicated in Table 2.5.4.3.1.1.

B. Vertical Spacing: Determine the minimum and maximum allowable vertical location of the sprinklers below the ceiling based on the distances indicated in Section 2.5.4.3.3. However, if the depth of the solid structural members prevents the guidelines from Section 2.5.4.3.3 from being implemented, locate the thermal element of the sprinklers on a plane not exceeding 6 in. (150 mm) below the underside of the solid ceiling structural members as demonstrated in Figure 2.5.4.4.4.

C. Channel-block the entire depth of the channels created by the solid ceiling structural members, as demonstrated in Figure 2.5.4.4.5, limiting each channel to a maximum volume of:

1. 400 ft<sup>3</sup> (11.3 m<sup>3</sup>) for ceiling slopes  $\leq 2$  in 12 ( $10^\circ$ ), or
2. 300 ft<sup>3</sup> (8.5 m<sup>3</sup>) for ceiling slopes over 2 in 12 ( $10^\circ$ ) but not more than 4 in 12 ( $18.5^\circ$ ).

When channel-blocking the entire depth of the channel formed by obstructed construction, open gaps up to 4 in. (100 mm) tall between the underside of the ceiling and the top of the ceiling structural members (such as those created by a corrugated steel deck roof) do not need to be filled.

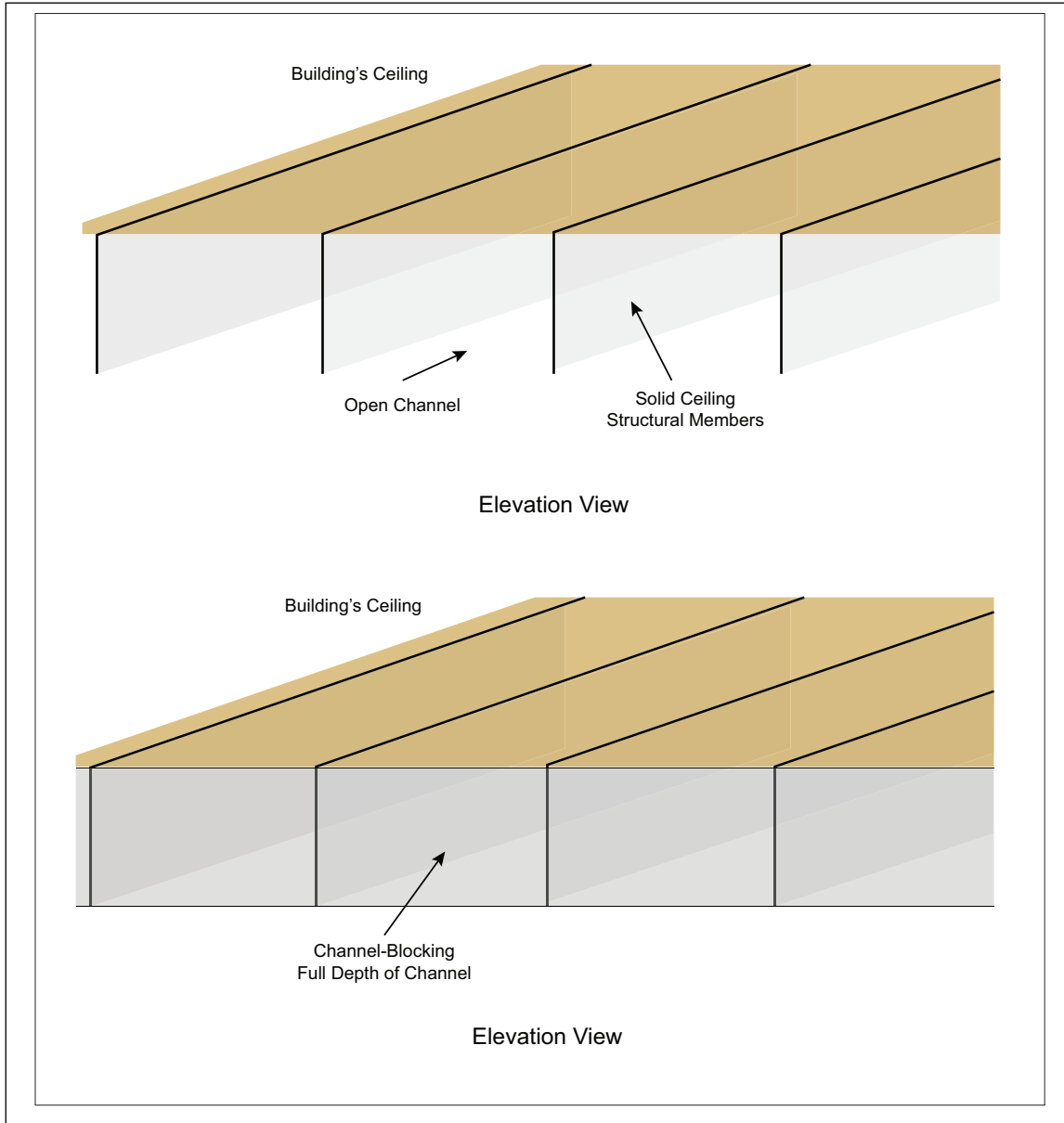

Fig. 2.5.4.4.5. Channel-blocking each channel created by obstructed ceiling construction

2.5.4.4.6 Install Storage sprinklers horizontally from walls, measured perpendicular to the wall, and wall corners as shown in Figure 2.5.4.3.2.

2.5.4.4.7 If the ceiling slope exceeds a pitch of 1 in 12 (5°), locate the sprinklers within 3 ft (0.9 m) of the ceiling peak as shown in Figure 2.5.4.3.4.1(b).

2.5.4.4.8 If the ceiling slope does not exceed a pitch of 2 in 12 (10°), install Storage sprinklers with their sprinkler deflectors either parallel to the ceiling or parallel to the floor.

2.5.4.4.9 If the ceiling slope exceeds a pitch of 2 in 12 (10°), install Storage sprinklers so their deflectors are parallel to the floor.

## 2.5.4.5 Obstruction to the Discharge Pattern of Ceiling-Level Storage Sprinklers

### 2.5.4.5.1 General Recommendations for Obstructions to Ceiling-Level Storage Sprinklers

2.5.4.5.1.1 Any object located entirely within the checkerboard area of Figure 2.5.4.5.1.1(a) for standard-coverage sprinklers or Figure 2.5.4.5.1.1(b) for extended-coverage sprinklers does not qualify as an obstruction to the sprinkler's discharge pattern.

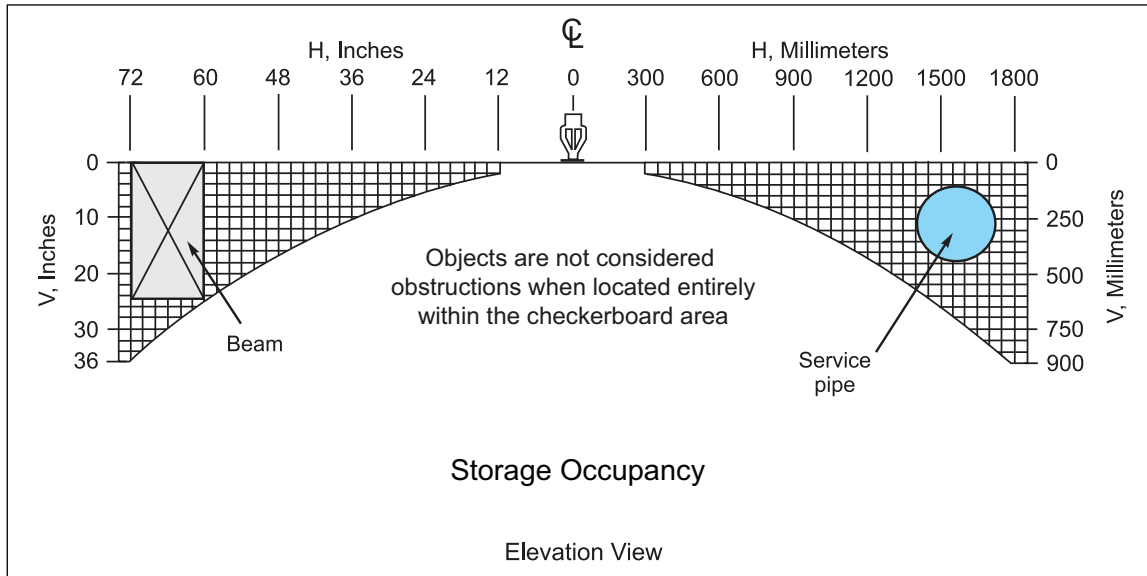

Fig. 2.5.4.5.1.1(a). Objects near ceiling level not considered obstructions to standard-coverage Storage sprinklers

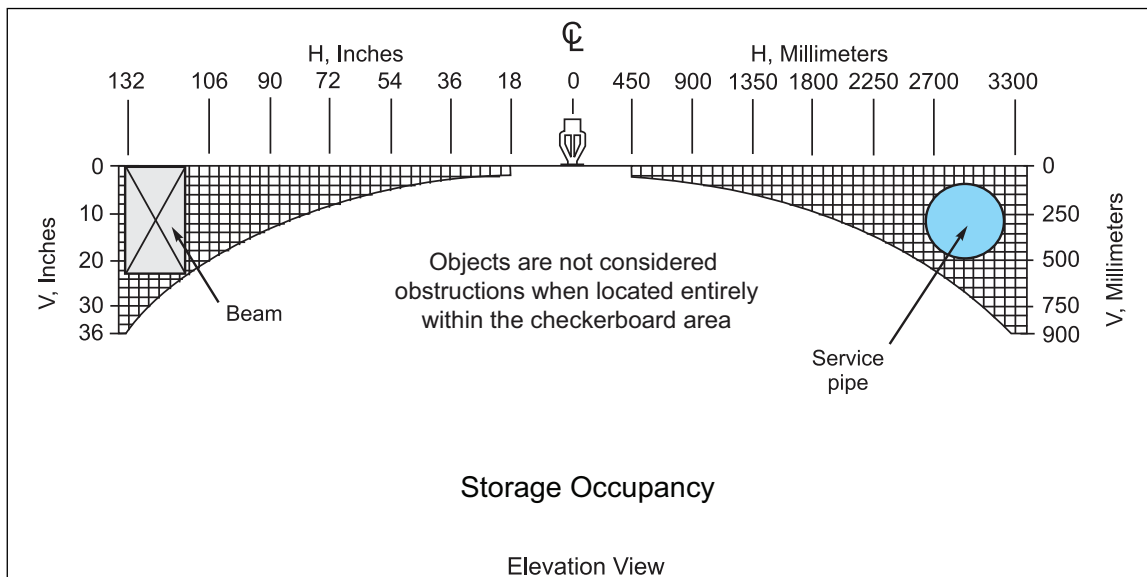

Fig. 2.5.4.5.1.1(b). Objects near ceiling level not considered obstructions to extended-coverage Storage sprinklers

2.5.4.5.1.2 If an object is not located entirely within the checkerboard, see the following sections to determine whether the object qualifies as an unacceptable obstruction to the sprinkler's discharge pattern.

2.5.4.5.2 Ceiling Structural Members and Other Similar Objects Located Near Ceiling-Level Storage Sprinklers

2.5.4.5.2.1 If ceiling structural members less than 70% open in their vertical profile, as demonstrated in Figure 2.5.4.5.2.1(a), position sprinklers on either side of the ceiling structural member as shown in Figure 2.5.4.5.2.1(b).

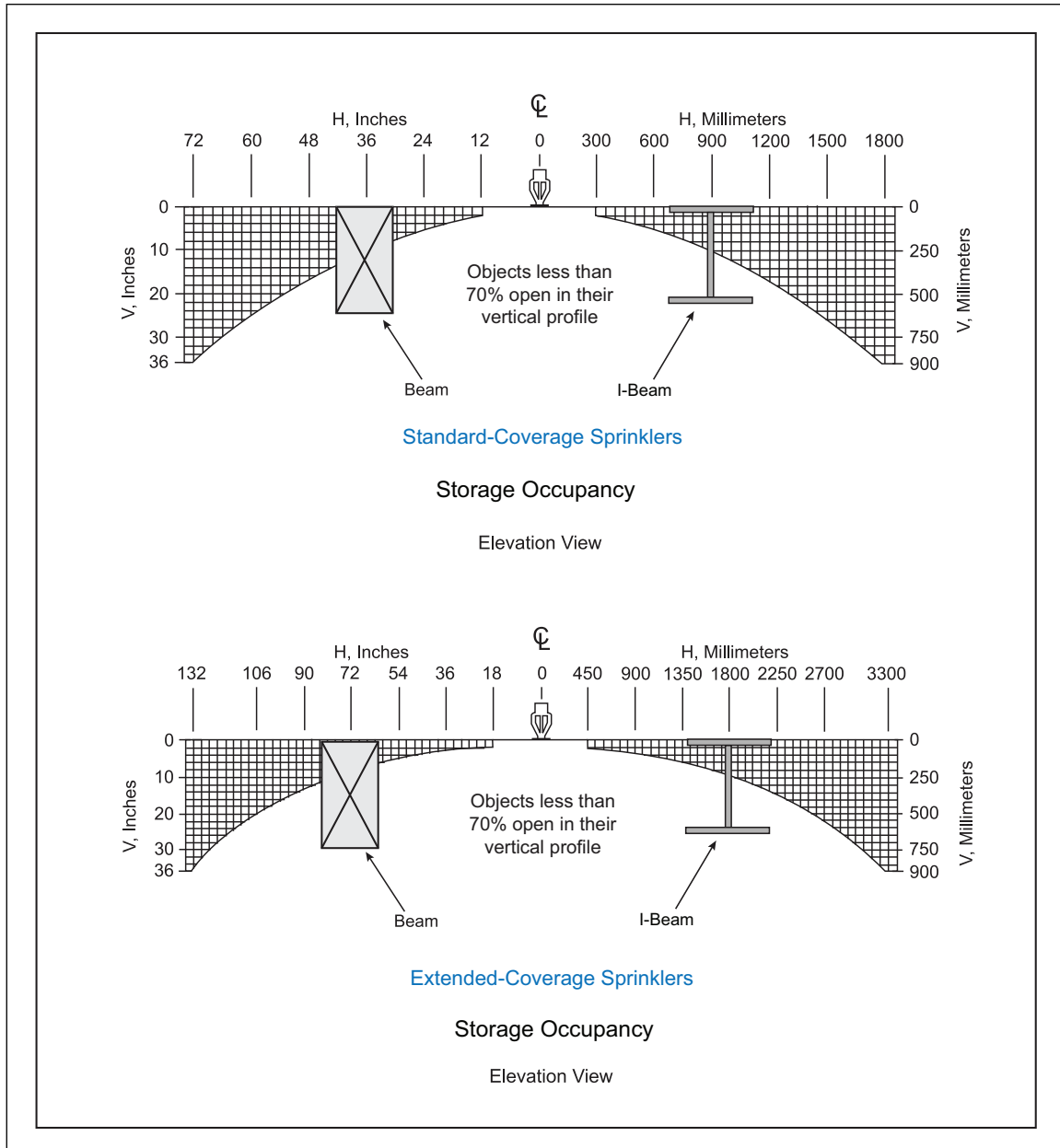

Fig. 2.5.4.5.2.1(a). Example of ceiling structural members that obstruct sprinkler discharge pattern

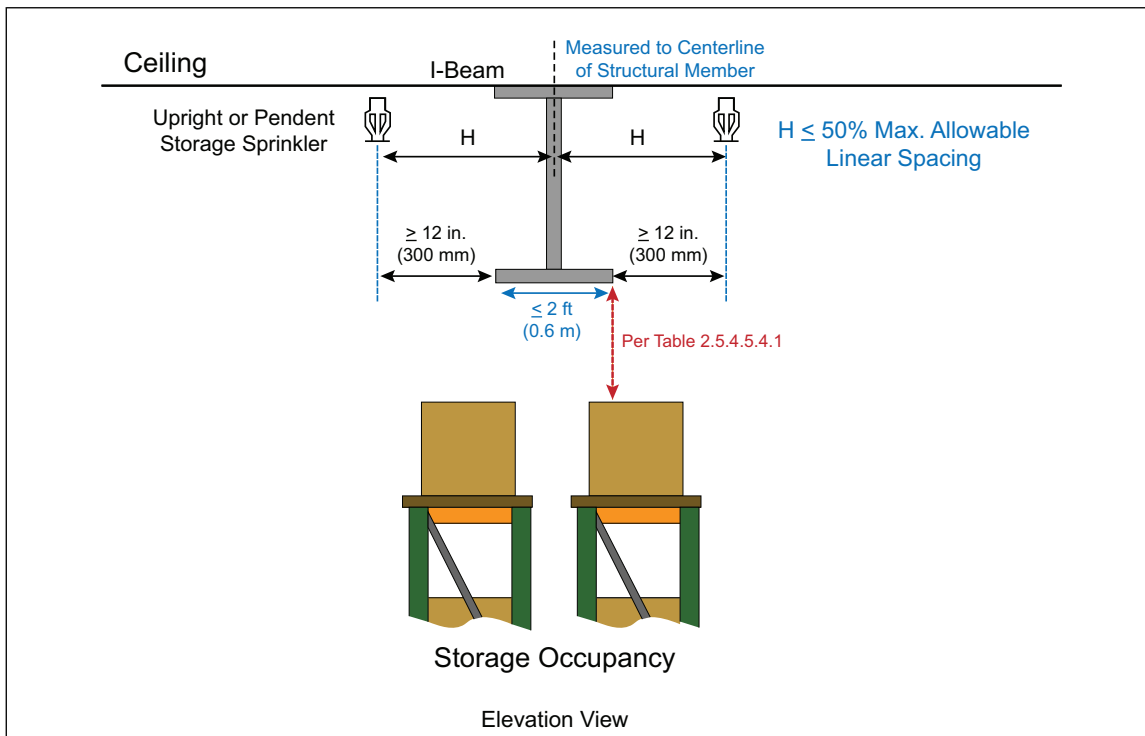

Fig. 2.5.4.5.2.1(b). Positioning ceiling-level sprinklers when ceiling structural members obstruct sprinkler discharge

2.5.4.5.2.2 Ceiling structural members 70% or more open in their vertical profile do not qualify as obstructions to the sprinkler's discharge pattern.

2.5.4.5.2.3 If ceiling structural members are a minimum of 70% open in their vertical profile, but are located less than 12 in. (300 mm) horizontally away from standard-coverage sprinklers, or less than 18 in. (450 mm) horizontally away from extended-coverage sprinklers, ensure that any cross-bracing or similar objects that make up the structural member are:

- A. No wider than 3 in. (75 mm), and
- B. Located a minimum horizontal distance of three times the width of the object from the sprinkler.

2.5.4.5.2.4 If the guidelines of Section 2.5.4.5.2.3 cannot be met, reposition a standard-coverage sprinkler so that it is a minimum of 12 in. (300 mm) horizontally from the nearest ceiling structural member, or 18 in. (450 mm) horizontally away from the nearest structural member if the sprinkler is extended-coverage.

### 2.5.4.5.3 Individual or Grouped Objects Located Below Ceiling-Level Storage Sprinklers

2.5.4.5.3.1 An object can be considered an "individual object" for the purpose of analyzing it as a potential obstruction to ceiling sprinkler discharge if it is located a minimum of 3 times its width from an adjacent object that is either the same size or larger. See Figure 2.5.4.5.3.1 for an example of applying this guidance.

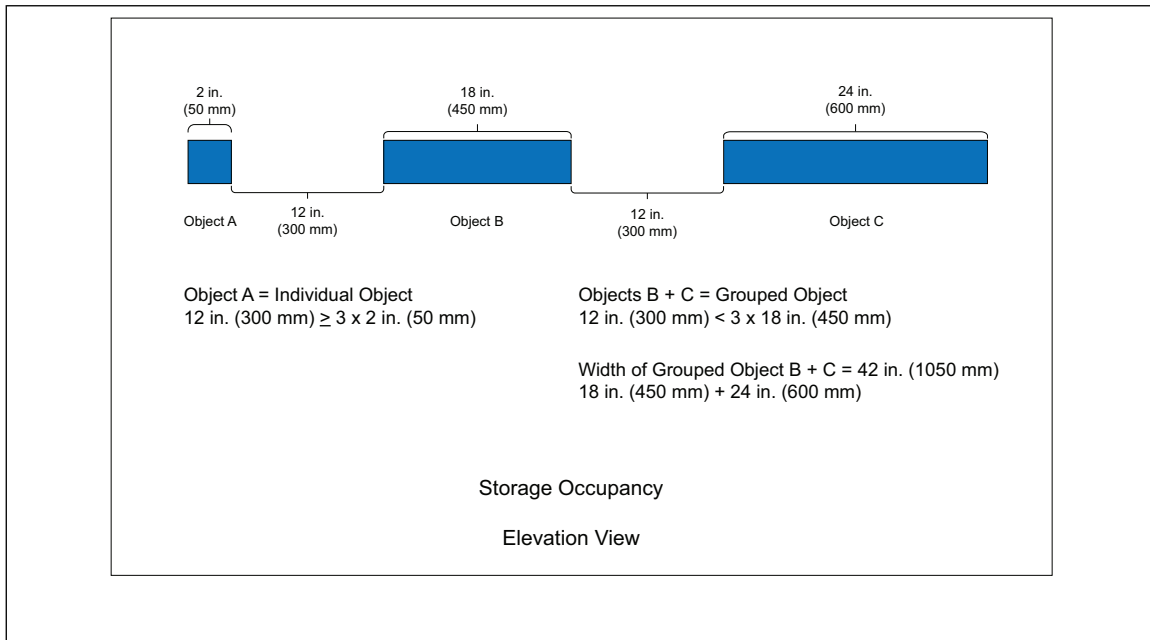

Fig. 2.5.4.5.3.1. Example of an "Individual Object" and a "Grouped Object" for analyzing obstructions

2.5.4.5.3.2 Group an object with an adjacent object of the same size or larger if the horizontal distance between the two objects is less than 3 times the width of the smaller object. See Figure 2.5.4.5.3.1 for an example of applying this guidance.

2.5.4.5.3.3 If two or more objects are considered a "grouped object", their overall width is the collective sum of each of the objects that make-up the grouped object; the open spaces between them do not need to be included in the calculation as demonstrated in Figure 2.5.4.5.3.1.

#### 2.5.4.5.4 Objects Up to 2 ft (0.6 m) Wide Located Below Ceiling-Level Storage Sprinklers and Above Storage

2.5.4.5.4.1 Objects located in accordance with Table 2.5.4.5.4.1 are not considered unacceptable obstructions to the discharge of Storage sprinklers. Note that the width of an object is measured in the object's least dimension and in a plane that is parallel to the floor.

Table 2.5.4.5.4.1. Acceptable Location of Obstructing Objects from Ceiling Sprinklers

Width of Object in its Least Dimension Measured Horizontally, in. (mm)	Horizontal Distance from Sprinkler to Nearest Edge of Obstructing Object, in. (mm)	Acceptable Criteria
≤ 0.75 (20)*	< 6 (150)	The obstructing object is an acceptable horizontal distance away from the sprinkler when it is a minimum of 4 in. (100 mm) vertically below the sprinkler
	≥ 6 (150)	The obstructing object is an acceptable distance away from the sprinkler
≤ 1.5 (38)*	< 6 (150)	The obstructing object is an acceptable horizontal distance away from the sprinkler when it is a minimum of 12 in. (300 mm) vertically below the sprinkler
	≥ 6 (150)	The obstructing object is an acceptable distance away from the sprinkler
≤ 2 (50)*	< 6 (150)	The obstructing object is an acceptable horizontal distance away from the sprinkler when it is a minimum of 24 in. (600 mm) vertically below the sprinkler
	≥ 6 (150)	The obstructing object is an acceptable distance away from the sprinkler
≤ 6 (150)*	< 6 (150)	The obstructing object is too close to the sprinkler and must be relocated a minimum of 6 in. (150 mm) horizontally from the sprinkler
	≥ 6 (150)	The obstructing object is an acceptable distance away from the sprinkler
≤ 12 (300)	< 12 (300)	The obstructing object is too close to the sprinkler and must be relocated to follow the guidelines indicated for the object being a minimum of 12 in. (300 mm) horizontally from the sprinkler
	≥ 12 (300)	The obstructing object is an acceptable horizontal distance away from the sprinkler, but it also must be located at least 18 in. (450 mm) above the top of storage
≤ 24 (600)	< 12 (300)	The obstructing object is too close to the sprinkler and must be relocated to follow the guidelines indicated for the object being a minimum of 12 in. (300 mm) horizontally from the sprinkler
	≥ 12 (300)	The obstructing object is an acceptable horizontal distance away from the sprinkler, but it also must be located at least 36 in. (900 mm) above the top of storage
> 24 (600)	See Section 2.5.4.5.5	See Section 2.5.4.5.5

\*See Section 2.5.4.5.4.2 if the ceiling sprinkler is upright

2.5.4.5.4.2 Objects up to a maximum width of 4 in. (100 mm) are not considered unacceptable obstructions to the discharge of upright Storage sprinklers. As a result, an upright sprinkler can be used as a replacement for an obstructed pendent sprinkler if:

- A. The upright sprinkler has the same attributes, other than orientation, that the pendent sprinkler has, and
- B. The upright sprinkler is an acceptable sprinkler to protect the occupancy hazard, and
- C. The object has a maximum width of 4 in. (100 mm).

2.5.4.5.4.3 If objects cannot be in accordance with Table 2.5.4.5.4.1 with the sprinklers installed in accordance with Table 2.5.4.3.1.1, the linear spacing of the sprinkler can be extended a maximum 1 ft (0.3 m) beyond the maximum linear spacing indicated in Table 2.5.4.3.1.1, as demonstrated in Figure 2.5.4.5.4.3, if that will allow the sprinkler to avoid unacceptable obstruction to its discharge. Note that the extended spacing is permitted multiple times, but each time must be adjacent to spacing that is in accordance with Table 2.5.4.3.1.1.

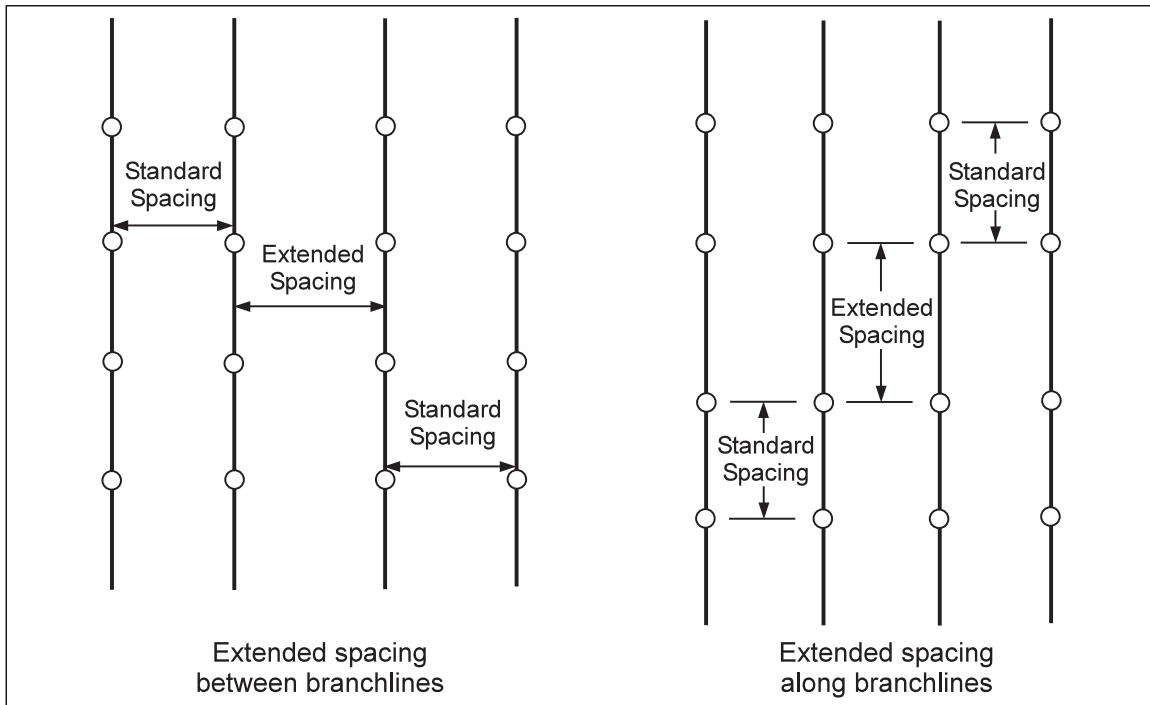

Fig. 2.5.4.5.4.3. Allowable extension of maximum ceiling sprinkler spacing to avoid obstruction to sprinkler discharge

2.5.4.5.4.4 If the guidelines from Sections 2.5.4.5.4.1 through 2.5.4.5.4.3 cannot be met to avoid unacceptable obstruction to ceiling sprinkler discharge, install supplemental sprinklers below the obstructing object as indicated in below and design the supplemental sprinklers as indicated in Section 2.5.4.5.4.5:

- A. Position the supplemental sprinklers within the footprint of the obstructing object on a vertical plane as close to the underside of the obstructing object as possible.
- B. When the obstructing object is flat and solid, the maximum allowable spacing for the supplemental sprinklers is 8 ft (2.4 m).
- C. When the obstructing object is either not flat, or is not solid, the maximum allowable spacing for the supplemental sprinklers is 4 ft (1.2 m). See Figure 2.5.4.5.4.4(a) for a visual representation of this arrangement.
- D. When the obstructing object is either not flat, or is not solid, but a flat continuous horizontal barrier having at least the same footprint of the obstructing object has been installed directly beneath it, the maximum allowable spacing for the supplemental sprinklers is 8 ft (2.4 m). See Section 2.5.4.5.4.6 for guidelines on the horizontal barrier.
- E. When the obstructing object is located over a storage rack, an acceptable protection option is the installation of supplemental sprinklers, having the same attributes as the ceiling sprinklers, at the top of the storage rack as in-rack sprinklers at all flue space intersections located below the obstructing object as shown in Figure 2.5.4.5.4.4(b).

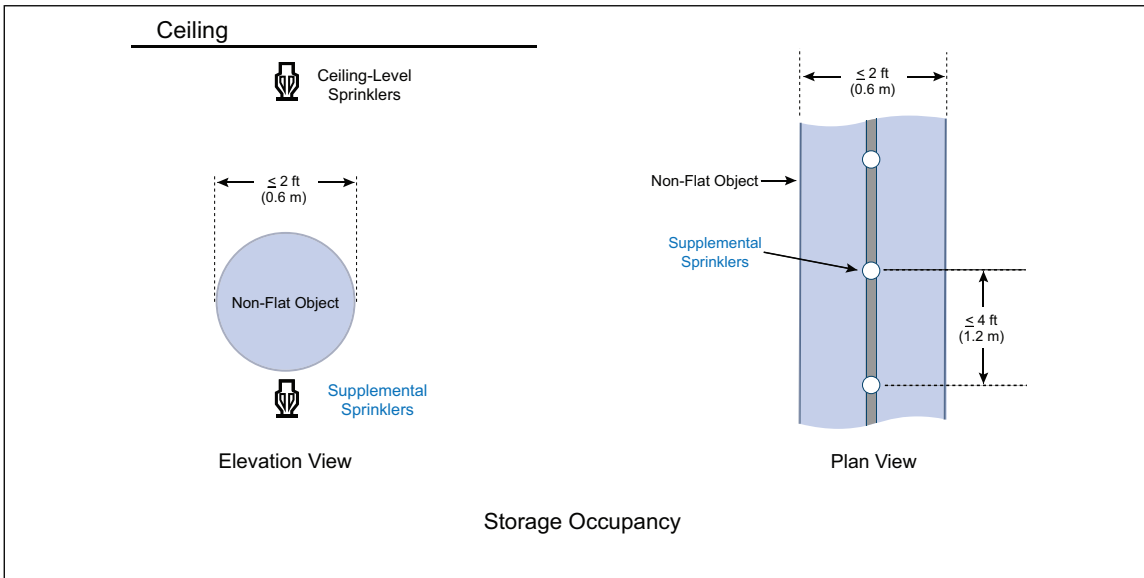

Fig. 2.5.4.5.4.4(a). Installing supplemental sprinklers under an obstructing object that is either not flat or is not solid

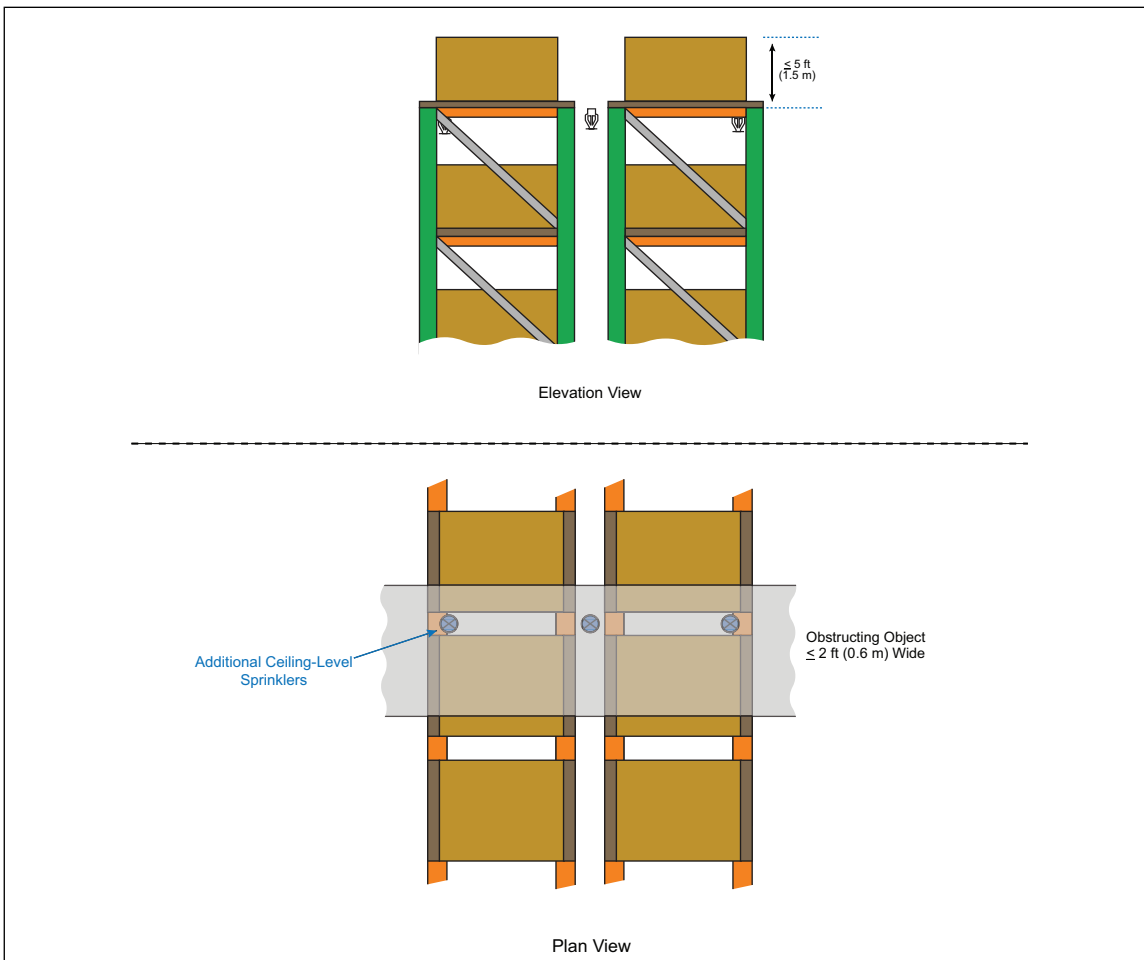

Fig. 2.5.4.5.4.4(b). Installing supplemental sprinklers within a storage rack under an obstructing object up to 2 ft (0.6 m) wide

2.5.4.5.4.5 Design the supplemental sprinklers being installed below the obstructing object as follows:

A. To avoid calculating the design of the supplemental sprinklers:

- (1) Use the same sprinklers installed at ceiling-level as the supplemental sprinklers, and
- (2) Feed them using a pipe size equal to or larger than the ceiling sprinkler system's maximum branch line size

B. An alternative to the design outlined in Item A is as follows:

- (1) Use the underside of the obstructing object as a fictitious ceiling height
- (2) Determine the recommended sprinkler system design from the occupancy-specific data sheet using the ceiling height obtained from Item B(1)
- (3) Account for the most remote 2 supplemental sprinklers providing the recommended design. This design does not need to be hydraulically balanced with the ceiling sprinkler system.

2.5.4.5.4.6 When a flat, solid, continuous horizontal barrier is to be installed below the obstructing object, use minimum 22-gauge (0.7 m) sheet metal or similar noncombustible material, and secure the barrier so it can resist and minimum uplift pressure of 3 lb/ft<sup>2</sup> (14.6 kg/m<sup>2</sup>). A less desirable but acceptable alternative to noncombustible materials includes the use of minimum 3/8 in. (10 mm) plywood (or similar material).

#### **2.5.4.5.5 Objects Over 2 ft (0.6 m) Wide Located Below Ceiling-Level Storage Sprinklers and Above Storage**

2.5.4.5.5.1 For individual or grouped objects over 2 ft (0.6 m) wide, design and install supplemental sprinklers under the obstructing object in accordance with Sections 2.5.4.5.5.2 through 2.5.4.5.5.5.

2.5.4.5.5.2 The design for the supplemental sprinklers is considered acceptable and does not need to be hydraulically balanced or accounted for in the ceiling sprinkler design when all the following conditions are met:

- A. The supplemental sprinklers are fed from a wet (or similar) sprinkler system, and
- B. The pipe size feeding the supplemental sprinklers is equal to or larger than the branch line pipe size of the overhead ceiling sprinkler system, and
- C. The supplemental sprinklers will have the same attributes (characteristics) as the ceiling sprinklers. Acceptable attribute differences include (1) the supplemental sprinklers are quick-response if the ceiling sprinklers are standard-response, or (2) the K-factor of the supplemental sprinklers is greater than the K-factor of the ceiling sprinklers or (3) the nominal temperature rating of the supplemental sprinklers is lower than the nominal temperature rating of the ceiling sprinklers.

2.5.4.5.5.3 Where the guidelines of Section 2.5.4.5.5.2 are not met, the design for the supplemental sprinklers, for the purpose of sizing the pipe feeding them, is determined as follows:

- A. Obtain the recommended pressure (specific to the attributes of the supplemental sprinkler) or density from the occupancy-specific data sheet for the occupancy hazard located below the obstruction by using the bottom of the obstruction, under which the supplemental sprinklers will be installed, as the "ceiling height" for design purposes, and
- B. Include all the supplemental sprinklers for the affected area, up to a maximum of four, in the design area. If more than one branch line will feed the supplemental sprinklers, the four sprinklers in the design can be accounted for using two sprinklers on two lines, and
- C. The required flow and pressure for the supplemental sprinkler design does not need to be hydraulically balanced with the overhead ceiling sprinkler system.

2.5.4.5.5.4 Install the supplemental sprinklers as follows:

- A. Position the supplemental sprinklers on a vertical plane as close to the underside of the obstructing object as possible.
- B. Install the supplemental sprinklers horizontally within the footprint of the obstructing object.

C. When supplemental sprinklers are to be installed below a flat, solid, obstructing object exceeding 2 ft (0.6 m) but not exceeding 10 ft (3.0 m) in width, the maximum allowable spacing of the supplemental sprinklers is 10 ft (3.0 m).

D. When supplemental sprinklers are to be installed below a flat, solid, obstructing object exceeding 10 ft (3.0 m) in width, the maximum allowable spacing of the supplemental sprinklers is in accordance with the sprinkler's linear and area spacing guidelines for unobstructed ceiling construction.

E. When supplemental sprinklers are to be installed below a non-flat or a non-solid, obstructing object exceeding 2 ft (0.6 m) in width, the maximum allowable linear spacing of the supplemental sprinklers is 4 ft (1.2 m); and the maximum allowable area spacing is 16 ft<sup>2</sup> (1.5 m<sup>2</sup>). Arrange the supplemental sprinklers so they are no more than 2 ft (0.6 m) horizontally from any edge of the obstructing object. See Figure 2.5.4.5.4(a) for a display of this arrangement.

F. When supplemental sprinklers are to be installed below a non-flat or a non-solid obstructing object exceeding 2 ft (0.6 m) but not exceeding 10 ft (3.0 m) in width that is equipped with a flat, solid, horizontal barrier having the same footprint as the obstructing object, the maximum allowable spacing of the supplemental sprinklers is 10 ft (3.0 m). See Section 2.5.4.5.5 for details regarding the barrier.

G. When supplemental sprinklers are to be installed below a non-flat or a non-solid obstructing object exceeding 10 ft (3.0 m) in width that is equipped with a flat, solid, horizontal barrier having the same footprint as the obstructing object, the maximum allowable spacing of the supplemental sprinklers is in accordance with the sprinkler's linear and area spacing guidelines for unobstructed ceiling construction. See Section 2.5.4.5.5 for details regarding the barrier.

H. When the width of the obstructing object does not exceed 4 ft (1.2 m), and it is located over a storage rack, an acceptable protection option is the installation of additional ceiling-level sprinklers as in-rack sprinklers. They should be positioned at all flue space intersections (face and longitudinal flue) at the top of the storage rack and fed by pipe having the same size as the overhead ceiling-level sprinkler system branch lines as shown in Figure 2.5.4.5.4(b).

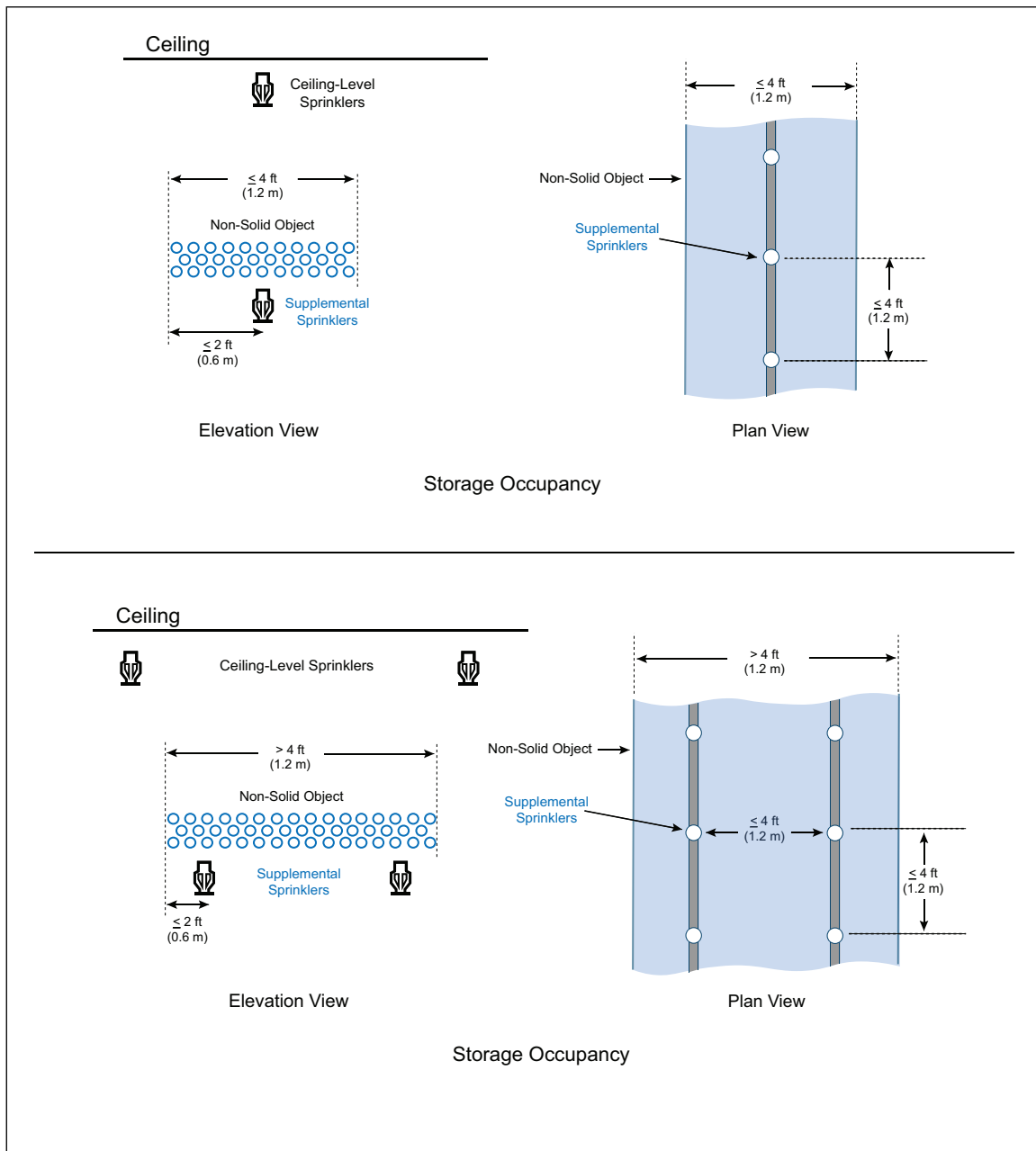

Fig. 2.5.4.5.5.4(a). Supplemental sprinklers installed below non-flat or non-solid obstructions, per Section 2.5.4.5.5

2.5.4.5.5.5 When a flat, solid, horizontal barrier is to be installed below an obstructing object, use minimum 22-gauge (0.7 mm) sheet metal or similar noncombustible material; and secure the barrier so it can resist a minimum uplift velocity pressure of 3 lb/ft<sup>2</sup> (14.6 kg/m<sup>2</sup>). A less desirable but acceptable alternative to noncombustible materials includes minimum 3/8 in. (10 mm) plywood (or similar material).

#### 2.5.4.5.6 Obstruction to Ceiling-Level Storage Sprinkler Discharge Due to Open-Grid Ceilings

2.5.4.5.6.1 Do not install open-grid ceilings in areas protected by Storage sprinklers.

#### 2.5.4.5.7 Obstruction to Ceiling-Level Storage Sprinkler Discharge Due to Open-Grid Mezzanines

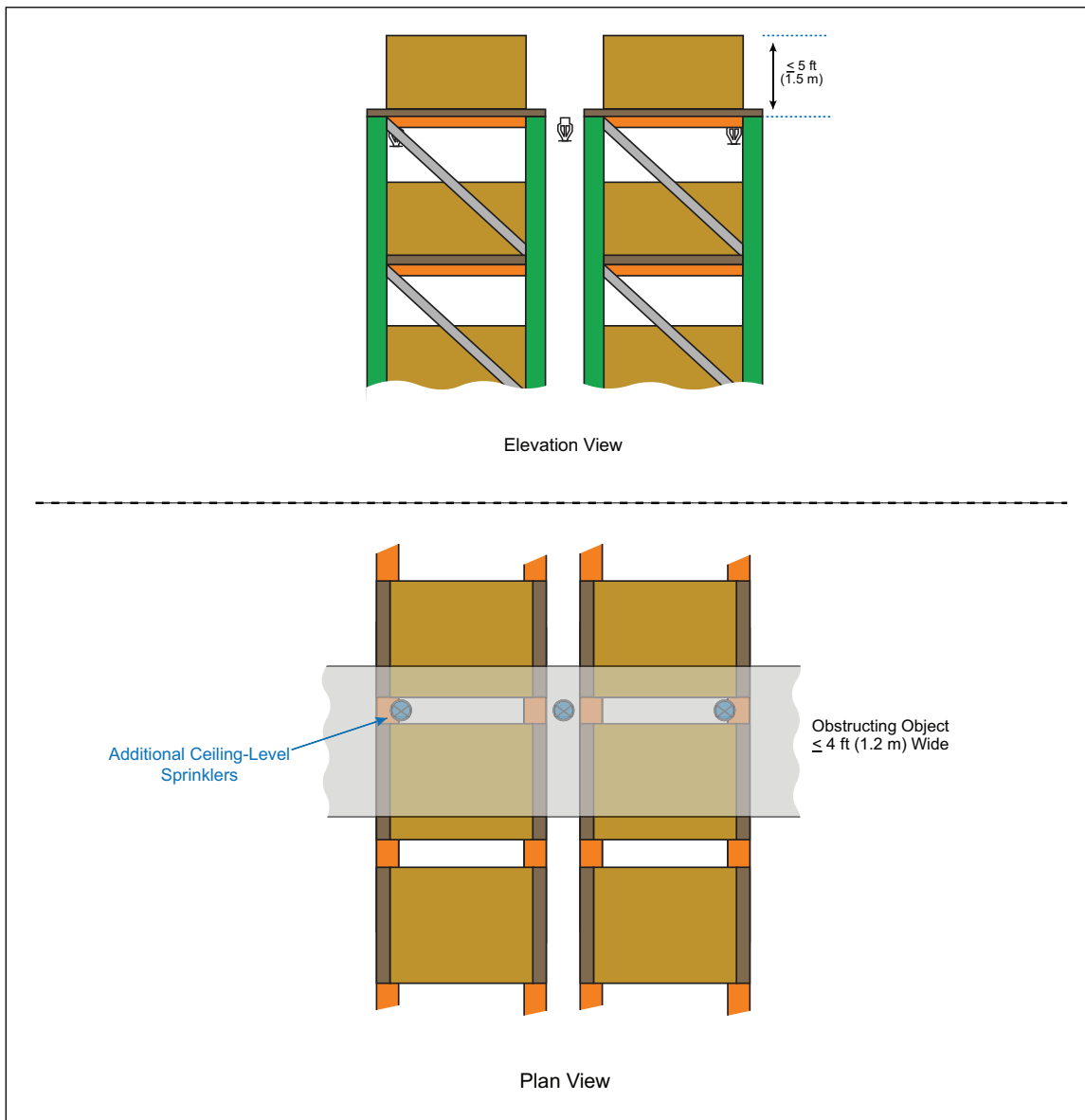

Fig. 2.5.4.5.5.4(b). Additional ceiling-level sprinklers installed within a storage rack below an obstructing object less than or equal to 4 ft (1.2 m) wide

2.5.4.5.7.1 Whenever possible, avoid the installation of an open-grid mezzanine (see definition in Appendix A). Instead, provide the mezzanine level with a solid flooring and install sprinklers under the solid flooring in accordance with Section 2.5.1.4.

2.5.4.5.7.2 If the presence of an open-grid mezzanine is unavoidable over storage, install sprinklers under an open-grid mezzanine as follows:

A. Sprinkler Type: 160°F (70°C) nominally rated, quick-response Storage sprinklers equipped with water shields.

B. Sprinkler Spacing: Do not exceed a linear spacing of 4 ft (1.2 m) nor an area spacing of 16 ft<sup>2</sup> (1.5 m<sup>2</sup>).

C. Sprinkler Design: For the occupancy hazard under the mezzanine as if the mezzanine was solid.

2.5.4.5.7.3 If sprinklers are installed in accordance with Section 2.5.4.5.7.2, the sprinkler system under the mezzanine does not need to be hydraulically balanced with the ceiling-level sprinkler system.

**2.5.4.5.8 Obstruction to Ceiling-Level Storage Sprinkler Discharge Due to Open-Grid Walkways**

2.5.4.5.8.1 Whenever possible, avoid the installation of an open-grid walkway (see definition in Appendix A). Instead, provide the walkway level with a solid flooring and install sprinklers under the solid flooring in accordance with Section 2.5.1.5.

2.5.4.5.8.2 Sprinklers may be omitted from the underside of an open-grid walkway that is a minimum of 70% open if:

- A. The area below the walkway will be void of any storage, or other combustible materials, and
- B. If the walkway is adjacent to rack storage, product from the racks is not expected to spill out onto the walkway during a fire event.

2.5.4.5.8.3 Sprinklers may be omitted from the underside of an open-grid walkway if:

- A. The walkway is located adjacent to a storage rack, and
- B. Face sprinklers are provided for the storage rack at the same level as the walkway.

2.5.4.5.8.4 If Sections 2.5.4.5.8.1 through 2.5.4.5.8.3 are not satisfied, install sprinklers under an open-grid walkway as follows:

- A. Sprinkler Type: 160°F (70°C) nominally rated, quick-response Storage sprinklers equipped with water shields that have the same K-factor, coverage-type, and orientation as the sprinklers being installed at ceiling level.
- B. Sprinkler Spacing: Install the sprinklers under the open-grid walkway using a maximum linear spacing of 8 ft (2.4 m).
- C. Sprinkler Design: Use the same branch line pipe size that is being installed at ceiling level.

2.5.4.5.8.5 As an acceptable alternative to the guidelines in Section 2.5.4.5.8.4, if the open-grid walkway is located adjacent to a storage rack that is protected with in-rack sprinklers, the sprinklers under the open-grid walkway can use the same sprinklers and in-rack sprinkler design that is being used for the in-rack sprinklers.

2.5.4.5.8.6, If sprinklers are installed in accordance with Sections 2.5.4.5.8.4 or 2.5.4.5.8.5, the sprinkler system under the walkway does not need to be hydraulically balanced with the ceiling-level sprinkler system.

**2.5.4.5.9 Obstruction to Ceiling-Level Storage Sprinkler Discharge Due to Conveyors.**

See the flowchart in Figure 2.5.4.5.9 to determine if supplemental sprinklers are recommended below the underside of conveyors.

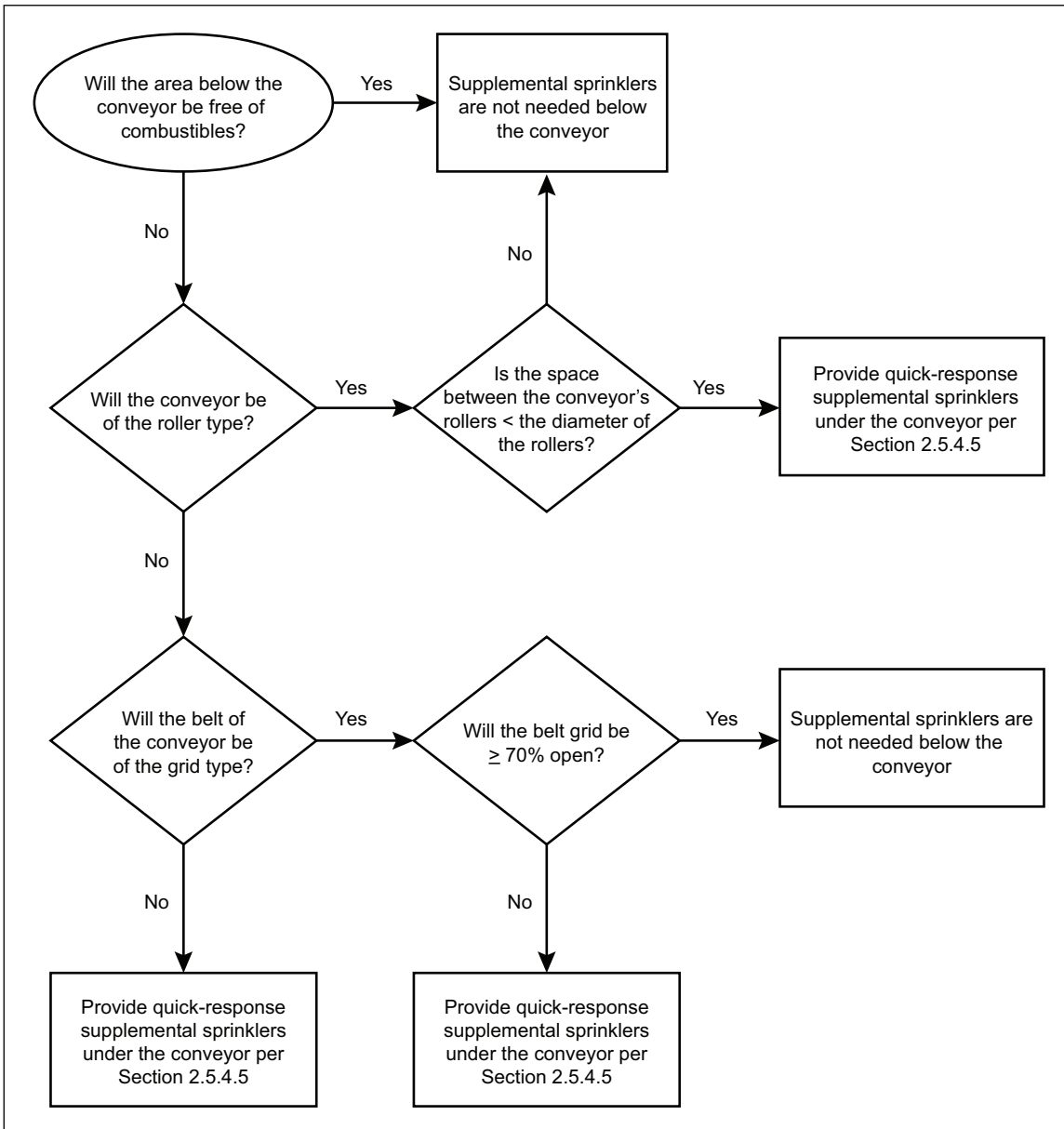

Fig. 2.5.4.5.9. Flowchart to determine if supplemental Storage sprinklers are needed below conveyors

**2.5.4.6 General Guidelines for the Positioning of In-Rack Sprinklers**

2.5.4.6.1 Locate all in-rack sprinklers within the rack storage structure.

2.5.4.6.2 Locate face sprinklers:

- A. Within the rack storage structure, and
- B. No more than 18 in. (450 mm) horizontally from the face of the storage rack

2.5.4.6.3 In-rack sprinklers may be located outside the rack storage structure of a single-row rack having a maximum 4 ft (1.2 m) depth if:

- A. Face sprinklers are not required, and
- B. The rack is located no more than 12 in. (300 mm) horizontally from a wall, and

C. The in-rack sprinklers are located no more than 6 in. (150 mm) horizontally away from the rack structure, and

D. The in-rack sprinklers are located no more than 3 in. (75 mm) horizontally offset from the transverse flue space intersection they are intended to protect, and

E. The in-rack sprinklers are offset to one side or the other of a rack upright

2.5.4.6.4 In-rack sprinklers may be located outside the rack storage structure of a single-row rack having a depth over 4 ft (1.2 m) if:

A. Face sprinklers have been installed along the aisle face of the rack, and

B. The rack is located no more than 12 in. (300 mm) horizontally from a wall, and

C. The in-rack sprinklers are located no more than 6 in. (150 mm) horizontally away from the rack structure, and

D. The in-rack sprinklers are located no more than 3 in. (75 mm) horizontally offset from the transverse flue space intersection they are intended to protect.

2.5.4.6.5 For double-row racks protected by in-rack sprinkler arrangements located only in the longitudinal flue space, position the in-rack sprinklers such that:

A. The in-rack sprinklers are offset to one side or the other of a rack upright, and

B. The in-rack sprinklers are not more than 3 in. (75 mm) offset horizontally from the transverse flue space intersection they are intending to protect.

2.5.4.6.6 At each tier level where in-rack sprinklers are to be installed, position the in-rack sprinkler deflector a minimum of 6 in. (150 mm) vertically above the top of storage and at or just below the bottom of the rack's horizontal support member when it is under full load conditions. If a minimum 6 in. (150 mm) clearance cannot be provided between the in-rack sprinkler and the top of storage, install in-rack sprinklers at all flue space intersections (face and longitudinal).

2.5.4.6.7 Face sprinklers are permitted to be installed above the bottom of the rack's horizontal support member that runs parallel to the storage aisle if the face sprinkler is offset a minimum of 3 in. (75 mm) from the horizontal support member.

2.5.4.6.8 Arrange in-rack sprinklers and their corresponding piping to avoid damage from material handling operations while also allowing for unobstructed in-rack sprinkler discharge. One potential way to accomplish this in a double-row rack would be to install two horizontal support members at the face of the rack, but only a single horizontal support member in the longitudinal flue space at the tier level where in-rack sprinklers are being installed. See Figure 2.5.4.6.8 for an example of this arrangement. Arrange the face sprinklers so they are between 3 in. (75 mm) to 18 in. (450 mm) horizontally from the horizontal support and their deflectors are no more than 3 in. (75 mm) above the underside of the nearest horizontal support, whereas arrange the longitudinal flue in-rack sprinklers so their deflectors are even with or slightly below the underside of the nearest horizontal support. Prior to installing in-rack sprinklers, check the proposed in-rack sprinkler locations to ensure both adequate protection against material handling operations damage and proper sprinkler discharge are provided.

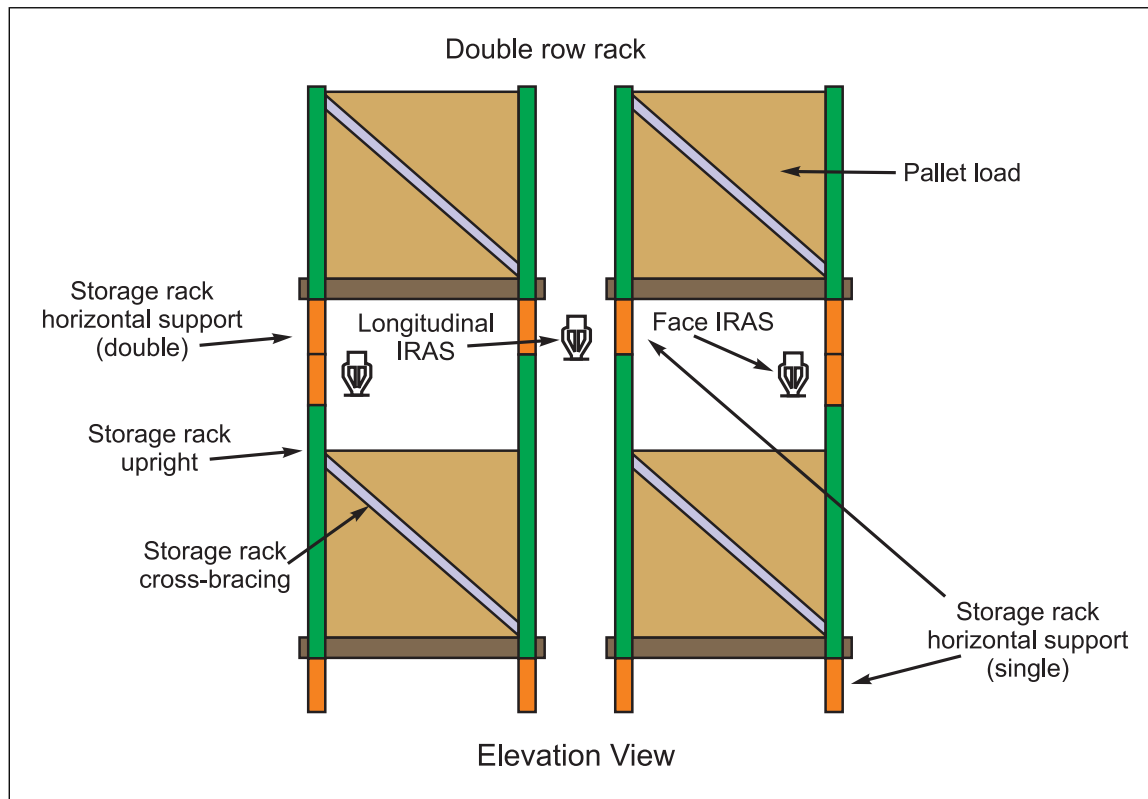

Fig. 2.5.4.6.8. Example of protecting in-rack sprinklers and sprinkler piping in a double-row rack

## 2.5.5 Special Protection Sprinklers

2.5.1 See the occupancy-specific data sheet for construction, occupancy, and protection guidelines regarding Special Protection sprinklers.

2.5.2 If not indicated in the occupancy-specific data sheet, see Section 2.2 to determine the type of sprinkler system (e.g., wet or dry) that is acceptable for the ambient temperature of the area to be protected.

2.5.3 See Section 2.3 for the applicable sprinkler system accessories.

2.5.4 See Section 2.4 for the installation recommendations regarding the sprinkler system's piping, connection, hanging, and bracing.

## 2.6 Plan Review of Sprinkler Systems

### 2.6.1 General Recommendations for Plan Review of Sprinkler Systems

2.6.1.1 Design the sprinkler system in accordance with the relevant occupancy-specific data sheet, and perform the hydraulic calculation analysis of the sprinkler system in accordance with Data Sheet 3-0, *Hydraulics of Fire Protection Systems*.

2.6.1.2 Submit one set of working drawings, sprinkler system hydraulic calculations, specifications, and any other required documentation as described in Sections 2.6.2 through 2.6.5 to a designated representative of FM for review and acceptance prior to the start of any sprinkler system installation.

2.6.1.3 Submit any revised working drawings, sprinkler system hydraulic calculations, specifications, and any other required documentation to a designated representative of FM for review and acceptance prior to the start of any sprinkler system installation.

2.6.1.4 Provide a complete set of final as built drawings, sprinkler system hydraulic analysis, specifications, and any required documentation to the building owner and/or customer for their files.

## 2.6.2 Working Drawings

2.6.2.1 Provide the information listed in Sections 2.6.2.2 through 2.6.2.5 on the working drawings submitted for review and acceptance.

2.6.2.2 Provide a scaled site plan showing the following:

- A. The water supply that is available for the property. Include any information regarding a fire pump house, fire pump, water supply tank, etc., if they are part of the on-site water supply system.
- B. All underground water supply mains and the control valves provided for them.
- C. All fire hydrants and the control valves for them.
- D. Any fire service pumper connections.
- E. All other similar related fire protection equipment (such as check valves, etc.).
- F. The building in which sprinkler protection is being installed.
- G. Any building within 100 ft (30 m) of the subject building.
- H. A direction arrow.
- I. All elevation differences between the effective point of the water supply test and the sprinkler system's base of riser.

2.6.2.3 Provide a scaled plan view sprinkler system drawing for each building being provided with sprinkler protection. For each drawing, show the following:

- A. All the nodes used in the hydraulic analysis.
- B. The design the sprinkler system is based on.
- C. The flow and pressure required for the sprinkler system, and the point of reference that the flow and pressure have been calculated to.
- D. The sprinkler SIN, K-factor, and nominal temperature rating for each sprinkler shown on the drawing.
- E. All components of the sprinkler system that are listed in Section 2.1.4.4; ensure they are adequately labeled.
- F. Any piping and outlets for inside hose stations and/or wall hydrants.
- G. The linear spacing of the sprinklers.
- H. Horizontal distances of sprinklers from walls.
- I. The location of any heat/smoke vents or power exhaust vents in relationship to the location of all sprinklers.
- J. The location of any areas where the ambient temperature of the occupancy is expected to be less than 40°F (4°C) or more than 130°F (54°C).

2.6.2.4 Provide scaled sectional view sprinkler system drawings for each building being provided with sprinkler protection. For each drawing, show the following:

- A. Vertical distances of sprinklers from ceilings.
- B. That all obstruction recommendations in Section 2.5.2.5 for Nonstorage pendent and upright sprinklers, Section 2.5.3.5 for Nonstorage sidewall sprinklers and Section 2.5.4.5 for Storage sprinklers are being met.

2.6.2.5 A scaled sectional view can be omitted if detailed information regarding obstructions to sprinklers and vertical distances between the ceiling and the sprinklers is provided on the plan view.

## 2.6.3 Sprinkler System Hydraulic Analysis

2.6.3.1 Unless recommended otherwise by the relevant occupancy-specific data sheet, prove via hydraulic analysis, as recommended in Data Sheet 3-0, *Hydraulics of Fire Protection Systems*, the proposed sprinkler system can provide the required design and duration specified in the relevant occupancy-specific data sheet.

2.6.3.2 See Section 2.6.5 for additional required documentation regarding sprinkler system hydraulic analysis.

### 2.6.4 Specifications

2.6.4.1 Submit specifications as described in Sections 2.6.4.2 through 2.6.4.12.

2.6.4.2 Submit specifications regarding any combustible construction for each area being provided with sprinkler protection and any areas being provided with heat/smoke vents and/or any open-grid ceilings, mezzanines, or walkways.

2.6.4.3 Submit specifications regarding the occupancy for each area being provided with sprinkler protection. For storage occupancies, see form FM999C, *FM Contractor's Hydraulic Analysis Certificate for Automatic Sprinkler Systems*.

2.6.4.4 Provide details regarding the occupancy of any area where the area's ambient temperature is expected to be less than 40°F (4°C) or more than 130°F (54°C).

2.6.4.5 Indicate the Year Zone designation of the area if it is in a 50-year through 500-year earthquake zone as defined in Data Sheet 1-2, *Earthquakes*, and indicate the provisions being taken to account for earthquake protection.

2.6.4.6 Submit detailed specifications on the water supply that will feed the sprinkler system. This includes, but is not limited to, information on the pump house, fire pump, and water storage tank, if they are part of the water supply. Use flow test data for any existing water supply that is no more than 12 months old. Water supplies that will include a new fire pump must include a copy of the pump's characteristic curve and follow the recommendations in Data Sheet 3-7, *Fire Protection Pumps*. If a water storage tank will be installed, specifications must be included to demonstrate its overall capacity, as well as its meeting the recommendations in Data Sheet 3-2, *Water Tanks for Fire Protection*.

2.6.4.7 Submit detailed specifications for each component of the sprinkler system, including, but not limited to, the following:

- Sprinklers
- Sprinkler system automatic system valve
- Sprinkler system quick opening devices
- Sprinkler system piping
- Sprinkler system pipe connections
- Sprinkler system pipe support assemblies
- Sprinkler system control valves and pressure regulating valves
- Sprinkler system check valves and backflow preventers
- Sprinkler system waterflow alarms
- Sprinkler system pressure gauges
- Sprinkler system fire service connections
- Sprinkler system drain valves
- Sprinkler system relief valves

2.6.4.8 Submit detailed specifications of the gaseous medium supply for any dry-pipe, preaction, or refrigerated-area type sprinkler system.

2.6.4.9 Submit detailed specifications on the antifreeze solution used in an antifreeze solution sprinkler system, and the expected lowest ambient temperature of the area being protected.

2.6.4.10 Submit detailed specifications on the actuating components of a preaction, refrigerated-area, vacuum, or deluge type sprinkler system and their sequence of operation.

2.6.4.11 Submit detailed specifications on any interlocks being provided for the sprinkler system, and their method of actuation.

2.6.4.12 Submit detailed specifications on the location that will be monitoring the alarms provided for the sprinkler system.

### 2.6.5 Required Documentation

2.6.5.1 Submit the documentation indicated in Sections 2.6.5.2 through 2.6.5.5 for review and acceptance.

2.6.5.2 Submit the FM *Contractor's Material and Test Certificate for Automatic Sprinkler Systems* form (FM85A) with all sections preceding the Automatic Sprinkler System Tests section completed by the installing contractor. See Appendix C for a copy of this form.

2.6.5.3 Submit a completed FM *Contractor's Hydraulic Analysis Certificate for Automatic Sprinkler Systems* form (FM999C). See Appendix C for a copy of this form.

2.6.5.4 Submit documentation showing that the expected water delivery time for any dry-pipe, preaction, refrigerated-area, vacuum, or deluge type sprinkler system can meet the maximum time allowance.

2.6.5.5 Upon receipt of FM's plan review correspondence, provide a revised submittal or written response to FM. The response should document how FMI's plan review recommendations will be addressed.

## 2.6.6 Arranging for FM Field Acceptance

Contact the local FM field servicing office to arrange field acceptance visits. The FM field servicing office will determine the scope of field examination and testing FM needs to witness. This depends on several factors, such as type of installation, hazard protected, size of the installation, and earthquake zone.

## 2.7 Sprinkler System Acceptance Tests

### 2.7.1 General Recommendations for Sprinkler System Acceptance Tests

Conduct an acceptance test on every new sprinkler system prior to placing it into service.

### 2.7.2 Recommended Documentation for Sprinkler System Acceptance Tests

2.7.2.1 Ensure all working drawings and specifications for the sprinkler system, as recommended in Section 2.6, have been submitted, reviewed, and found acceptable to FMI.

2.7.2.2 Verify any outstanding recommendations listed on FM plan review correspondence have been addressed to the satisfaction of FM.

2.7.2.3 Confirm that all required fields of the FM *Contractor's Material and Test Certificate for Automatic Sprinkler Systems* form (FM85A) have been completed by the installing contractor and that a copy of the form has been left with a designated representative of FM. See Appendix C for a copy of this form.

2.7.2.4 For sprinkler systems where holes were cut into the sprinkler pipe for the installation of quick-connect fittings, documented confirmation is required that all cutouts (coupons) have been removed from the interior of the sprinkler pipe. The installing contractor can provide this documented confirmation by:

- A. Providing written confirmation on the *Contractor's Material and Test Certificate* (form FM85A) that all cutouts (coupons) have been removed from the pipe, or
- B. Stating in a separate letter that all cutouts have been removed from the interior of the sprinkler pipe.

2.7.2.5 Confirm that all required fields of the FM *Contractor's Hydraulic Analysis Certificate for Automatic Sprinkler Systems* form (FM999C) have been completed by the installing contractor and that a copy of the form has been left with a designated representative of FM. See Appendix C for a copy of this form.

### 2.7.3 Recommended Testing for a Sprinkler System Acceptance Test

#### 2.7.3.1 Testing of Water Supply and Underground Mains

2.7.3.1.1 Confirm by way of a full-flow test that the actual water supply available to the sprinkler system is equal to or greater than the available water supply indicated on the submitted and accepted working drawings.

2.7.3.1.2 Hydrostatically test all underground piping in accordance with Data Sheet 3-10, *Private Fire Service Mains and Connections*. Ensure the allowable leakage is within the limits prescribed by Data Sheet 3-10 and recorded on the test certificate.

#### 2.7.3.2 Hydrostatic Testing of the Sprinkler System

2.7.3.2.1 Hydrostatically test all new sprinkler systems to a minimum pressure of 200 psi (13.8 bar), or to 50 psi (3.5 bar) more than any sprinkler system static pressure that exceeds 150 psi (10.3 bar), for 2 hours without pressure loss. Ensure that all interior sprinkler system pipe, as well as any attached accessories

that are subjected to system working pressure, are included as part of the test. Pressure loss can be determined either by monitored pressure gauges or visual observation. Read the test pressure from a gauge located at the low elevation point of the system or portion being tested.

2.7.3.2.2 If an existing sprinkler system is modified, hydrostatic testing is not required of the entire sprinkler system, but rather just the portion that was modified. However, if the modified section(s) of the sprinkler system cannot be isolated, such as relocated drops, hydrostatically test the entire sprinkler system at its normal static pressure for a minimum of 2 hours without pressure loss.

2.7.3.2.3 Hydrostatic testing of an existing sprinkler system is not required if the only modification to the sprinkler system involves the replacement of sprinklers.

2.7.3.2.4 Where cold weather will not permit testing with water, an interim pneumatic leakage test may be conducted as described in Section 2.7.3.2.7.

2.7.3.2.5 To reduce the possibility of serious water damage in the event of a pipe rupture, pressure may be maintained by a small pump while keeping the main control valve to the sprinkler system shut during the test.

2.7.3.2.6 When hydrostatically testing a sprinkler system, give special attention to the following sprinkler system pipe and components:

A. Differential Dry-Pipe Valve: To prevent damage to a differential dry-pipe valve, keep the clapper of the dry-pipe valve off its seat during the hydrostatic test.

B. Fire service Connection: Hydrostatically test the pipe installed between the exterior fire service connection and the check valve in the fire service inlet pipe.

C. Polybutylene Pipe: When hydrostatically testing polybutylene pipe, it will undergo expansion during initial pressurization. In this case, a reduction in gauge pressure may not necessarily indicate a leak. The pressure reduction should not exceed the manufacturer's specifications and listing criteria.

D. Deluge Sprinklers: When deluge systems are being hydrostatically tested, do one of the following:

1. Install plugs in the sprinkler fittings and replace them with open sprinklers after the test has been completed, or
2. Remove the operating elements of the sprinklers once the test has been completed.

2.7.3.2.7 In addition to the standard hydrostatic test, conduct a pneumatic leakage test on all dry-pipe, preaction, refrigerated-area, or vacuum type sprinkler systems at 40 psi (2.8 bar) for a minimum duration of 24 hours. Correct any leakage that results in a loss of more than 1½ psi (0.1 bar) pressure over the 24-hour time duration. Note that the maximum 1½ psi (0.1 bar) per 24-hour leakage rate applies to the collective effect of all leaks, not individual leaks.

2.7.3.2.8 Where sprinkler systems are installed to protect spaces that could have ambient temperatures below 32°F (0°C), conduct the pneumatic leakage test at the lowest nominal temperature of the space.

2.7.3.2.9 Do not pneumatically test sprinkler systems having rigid thermoplastic piping such as CPVC. Always test sprinkler systems having rigid thermoplastic piping with water making sure that any air in the system is bled out from the highest and farthest sprinklers in the system.

2.7.3.2.10 Arrange test blanks so they have painted lugs protruding in such a way as to clearly indicate their presence. Number the test blanks and create a record keeping method that will ensure that the installing contractor removes them after the work has been completed.

2.7.3.2.11 Do not use additives, corrosive chemicals such as sodium silicate or derivatives of sodium silicate, brine, or other chemicals for stopping leaks when hydrostatically testing a sprinkler system.

2.7.3.2.12 Make provisions for the proper disposal of water used for hydrostatic testing.

### 2.7.3.3 Testing of Dry-Pipe, Preaction, Refrigerated-Area, Vacuum, or Deluge Type Sprinkler Systems

2.7.3.3.1 In addition to flushing and hydrostatic tests, arrange the installing contractor to conduct a trip test of any dry-pipe, preaction, refrigerated-area, vacuum, or deluge type sprinkler systems prior to acceptance. Arrange for the test(s) to be witnessed by a representative of the owner.

2.7.3.3.2 See the relevant occupancy-specific data sheet to see if there are any recommendations for the trip testing of a sprinkler system that supplement those provided here. For example, Data Sheet 7-93N, *Aircraft Hangars*, contains very specific guidelines pertaining to acceptance tests.

2.7.3.3.3 In special cases, such as with anechoic chambers, where values may be high and there is a concern with possible damage during full-flow acceptance tests (see Data Sheet 1-53, *Anechoic Chambers*), or with freezers where water may freeze, make every effort to complete acceptance testing prior to introducing any high-value contents or before bringing the freezer temperature down to the operating level.

2.7.3.3.4 Conduct the trip test of the sprinkler system with all water supplies, including fire pumps, in service and with all the sprinkler system control valves fully open and the system set for normal operation. Conduct the trip tests as follows:

A. Dry-Pipe Systems: Trip the dry-pipe system by opening the inspector's test connection, or inspector's test connection assembly if the sprinkler system is designed based on the operation of more than one remote sprinkler. Measure the pressure at which the dry-pipe valve trips and the time it takes for the pressure at the inspector's test connection to ramp up to and maintain the minimum design pressure for the sprinkler system. Document this information on FM Form FM85A.

B. Preaction-Type Systems (i.e., Preaction, Refrigerated-Area, or Vacuum Type Sprinkler Systems): Trip the preaction-type system by first activating a heat- or smoke-responsive actuating device. If heat detectors are used, test the system by applying heat to a heat detector; if smoke detection is used, test the system by using an Approved simulated smoke dispenser. If wet or dry pilot sprinklers are used, test the system by fusing a sprinkler or by opening the pilot line test connection at the end of the pilot line system. For non-interlock and single-interlock preaction systems this will trip the sprinkler system. For double-interlock preaction sprinkler systems, the sprinkler system is then tripped by opening the inspector's test connection or the inspector's test connection assembly if the sprinkler system is designed based on the operation of more than one remote sprinkler. For non-interlock preaction sprinkler systems, repeat the trip test by only opening the inspector's test connection or inspector's test connection assembly to confirm it will trip via both methods. For non-interlock and double-interlock type systems, measure the pressure at which the system valve trips and the time it takes for the pressure at the inspector's test connection to ramp up to and maintain the minimum design pressure for the sprinkler system. Document this information on FM Form FM85A.

C. Deluge and Exposure Protection Sprinkler Systems: In addition to the recommended procedure for a preaction-type sprinkler system, test the automatic operation of a deluge valve in accordance with the manufacturer's instructions. Where present, also test the manual and remote-control operation of the system. Observe the sprinkler discharge to ensure uniformity. Measure the discharge pressure at the most hydraulically remote sprinkler using a calibrated gauge located as close as possible to the remote sprinkler to ensure performance is in accordance with design. Also, ensure that drainage to a safe location is adequate.

2.7.3.3.5 During this test, also check for proper operation of supervisory equipment, waterflow alarms, and interlocking controls for starting fire pumps, stopping conveyors, shutting down air-handling systems, etc.

2.7.3.3.6 After a successful full-flow trip test of a preaction type sprinkler system, make additional trip tests to ensure proper operation of each circuit of heat- or smoke-responsive devices and manual trip stations, both local and remote. Conduct these tests with the system control valve throttled.

2.7.3.3.7 After successful completion of the trip test, drain the sprinkler system of water and place the system in service.

### 2.7.3.4 Testing of Sprinkler System Components

2.7.3.4.1 Verify via physical testing that all sprinkler system control valves are in the fully open position. Ensure any tamper alarms provided for the sprinkler system control valves function properly during the physical testing of the control valves. See Data Sheet 2-81, *Fire Safety Inspections and Sprinkler System Maintenance*, for guidelines specific to physical testing of control valves.

2.7.3.4.2 Ensure any alarms provided for the sprinkler system are received at the alarm control panel, and at the alarm monitoring station, if one is provided. If local alarms are provided, ensure they function properly.

2.7.3.4.3 Conduct a 2-in. (50-mm) main drain test by opening the main drain valve and keeping it open until the system pressure stabilizes. Record the static and residual pressures and document their values on FM Form FM85A.

2.7.3.4.4 Confirm that any interlocks that are activated by the operation of a sprinkler system function properly.

2.7.3.4.5 If installed, forward flow-test the backflow prevention assembly to ensure proper operation. Use a minimum flow rate equal to that of the sprinkler system demand, including hose stream demand where applicable.

2.7.3.4.6 If installed, test each pressure-reducing valve upon completion of installation to ensure proper operation under flow and no-flow conditions. Verify that the device properly regulates outlet pressure at both maximum and normal inlet pressure conditions. Record the results of the flow test for each pressure-reducing valve on FM Form FM85A. Document the static and residual inlet pressures, static and residual outlet pressures, and the flow rate.

2.7.3.4.7 If written documentation of coupon removal has not been provided in accordance with Section 2.7.2.4, conduct a full flushing of all sprinkler pipe followed by a visual check of the sprinkler system prior to acceptance of the system and placing the system in service to ensure that all cutouts have been removed. The visual check is needed to ensure that cutouts have not become lodged in smaller diameter pipe.

### 2.7.3.5 Visual and Final Review of the Sprinkler System

2.7.3.5.1 Visually review the sprinkler system pipe arrangement to ensure it has been installed per the reviewed and accepted working drawings. Ensure any deviations from the working drawings have been listed and are considered acceptable to FM.

2.7.3.5.2 If dry-pipe, preaction, refrigerated-area, or vacuum sprinkler systems have been installed, ensure proper sprinkler pipe pitch and any required auxiliary drainage has been provided for the sprinkler system.

2.7.3.5.3 Ensure a cabinet for spare sprinklers has been provided for each sprinkler system as recommended in Section 2.5.1.13.

2.7.3.5.4 Verify that all equipment identification tags have been provided where needed.

2.7.3.5.5 Once the acceptance test has been completed and proper documentation has been provided to the designated FM representative, verify that all aspects of the sprinkler system, including all alarms and interlocks, have been placed in service.

## 2.8 Operation and Maintenance

See Data Sheet 2-81, *Fire Safety Inspections and Sprinkler System Maintenance*, for guidelines on the operation and maintenance of sprinklers and sprinkler systems.

## 2.9 Ignition Source Control

2.9.1 Ensure all hot work operations associated with the installation of a sprinkler system are safeguarded as recommended in Data Sheet 10-3, *Hot Work Management*.

## 3.0 SUPPORT FOR RECOMMENDATIONS

### 3.1 General

3.1.1 The fire protection recommendations in this data sheet are based on testing, loss experience, and engineering judgment. Not every situation has been tested, nor has every potential solution been identified. Carefully consider all the variables involved when exploring options different from those covered in this data sheet.

3.1.2 The recommendations in this data sheet are aimed at ensuring the following:

- A. Sprinklers will operate in a timely fashion.
- B. Sprinklers will have an unobstructed water discharge pattern.
- C. Sprinkler system components will function in a reliable manner.

3.1.3 The recommendations in this data sheet must be combined with the design parameters in the relevant occupancy-specific data sheets to ensure the sprinkler system will provide a sufficient volume of water to control or suppress a fire.

## 3.2 Loss History

### 3.2.1 General

3.2.1.1 Automatic sprinklers have been commercially available for well over 100 years. The loss history of facilities equipped with sprinkler systems is excellent when they have been installed in accordance with the recommendations in this data sheet.

3.2.1.2 The majority of large fire losses at industrial facilities is primarily due to lack of sprinkler protection.

3.2.1.3 FM loss history over the past 20 years indicates that approximately 25% of the time, the operation of a single sprinkler will control or suppress a fire if the sprinkler system has been properly designed and installed. This percentage increases to approximately 50% with the operation of three or fewer sprinklers, and 75% the operation of nine or fewer sprinklers. There are other publicly available sources that indicate even better results.

3.2.1.4 The maximum number of sprinklers that operate during a fire will typically do so well before the fire service can reach the fire and begin attacking it. Providing sprinkler protection in accordance with this data sheet can mean the difference between the fire service arriving to find a relatively small fire and one that is uncontrolled.

3.2.1.5 Loss experience with storage sprinklers is very limited; however, the storage sprinkler has generally performed very well, with excellent fire control or suppression provided by operating sprinklers. In storage occupancies, fires under storage sprinklers tend to be shorter lived, smaller, and result in fewer sprinklers operating compared to fires under nonstorage sprinklers.

### 3.2.2 Loss Examples

#### 3.2.2.1 Hot Work at Facility with Sprinklers in the Process of Being Installed

A fire caused by contractor welding damaged a chicken-processing plant. Sprinklers were being installed in the area but had not yet been placed into service. The fire involved wall insulation consisting of polystyrene board covered with fiberglass-reinforced plastic. The fire spread to polyurethane insulation that had been sprayed onto a lap-seam steel-on-steel roof, resulting in about 28,000 ft<sup>2</sup> (2,600 m<sup>2</sup>) of roof collapse. Fire spread to a maintenance shop, motor control centers, and corrugated box storage areas. Equipment in the collapsed area was severely damaged. Contractors were welding within 4 in. (100 mm) of the combustible insulation. The plant's hot work permit system was not followed. A fire watch was not posted, and fire extinguishers were not present.

#### 3.2.2.2 Arson at a Facility with Newly Installed Sprinklers but Not Yet Connected to Water Supply

A fire took place at a fiber optic cable manufacturing plant where arson was deemed the most likely cause. The fire occurred in a roughly 7,500 ft<sup>2</sup> (700 m<sup>2</sup>) building section where raw materials (mainly plastic pellets) were being stored on racks to a height of 13 ft (3.9 m). The roof and walls of this building section consisted of plastic insulated sandwich panels. Sprinkler protection had been installed in this area but was not yet in service because work was not yet completed on the fire pump. During the fire both the roof and walls of this section of building collapsed. Production equipment and in-process product in an adjoining section were damaged. Smoke damage was also extensive in adjoining buildings. Smoke damage was extensive because of doors left open between adjoining buildings. Although fire detection was prompt, due to the operation of burglary and smoke alarms, response by the paid fire service was delayed by over 20 minutes.

#### 3.2.2.3 Fire Loss at High-Rise Facility Equipped with Sprinklers but Not in Fire Area

A fire took place at a large complex that included 2,900 hotel rooms, a gambling casino, convention hall and shopping areas. Arson by an employee was determined to be the cause of fire origin.

The employee set fire to four separate areas of the complex. In one area the fire originated on the eighth floor of one of three 30 story wings. The absence of sprinklers in this area allowed the fire to spread from the drapes in an elevator lobby through large broken windows to the 28th floor where it was halted by concrete

floors extending at least 5 ft (1.5 m) beyond concrete curtain walls. Severe fire damage occurred to carpeting, vinyl wall coverings and wooden guest room doors on all affected floors. The interiors of at least seven guest rooms were burned after departing guests left doors open. Smoke damage was extensive in all hallways and about 50% of the rooms in the wing where the fire occurred. Part of another wing also experienced smoke damage.

Of the other remaining three affected areas, one fire was started in a uniform storage room that was equipped with sprinkler protection. The fire opened one sprinkler, which controlled the fire. The fires in the other two areas self-extinguished due to the limited combustibles that were present.

The entire complex had to be shut down for about three weeks whereas the hotel wing where the fire started, including about 900 damaged rooms, had to be shut down for much longer.

## 4.0 REFERENCES

### 4.1 FM

Data Sheet 1-2, *Earthquakes*  
Data Sheet 1-12, *Ceilings and Concealed Spaces*  
Data Sheet 1-20, *Protection Against Exterior Fire Exposure*  
Data Sheet 1-31, *Panel Roof Systems*  
Data Sheet 1-44, *Damage-Limiting Construction*  
Data Sheet 1-53, *Anechoic Chambers*  
Data Sheet 1-57, *Plastics in Construction*  
Data Sheet 2-1, *Corrosion in Automatic Sprinkler Systems*  
Data Sheet 2-8, *Earthquake Protection for Water-Based Fire Protection Systems*  
Data Sheet 2-81, *Fire Safety Inspections and Sprinkler System Maintenance*  
Data Sheet 3-0, *Hydraulics of Fire Protection Systems*  
Data Sheet 3-1, *Tanks and Reservoirs for Interconnected Fire Service and Public Mains*  
Data Sheet 3-2, *Water Tanks for Fire Protection*  
Data Sheet 3-4, *Embankment-Supported Fabric Tanks*  
Data Sheet 3-6, *Lined Earth Reservoirs for Fire Protection*  
Data Sheet 3-7, *Fire Protection Pumps*  
Data Sheet 3-10, *Private Fire Service Mains and Connections*  
Data Sheet 3-11, *Flow and Pressure Regulating Devices for Fire Protection Service*  
Data Sheet 3-26, *Fire Protection Water Demand for Nonstorage Sprinklered Properties*  
Data Sheet 3-29, *Reliability of Fire Protection Water Supplies*  
Data Sheet 5-40, *Fire Alarm Systems*  
Data Sheet 5-48, *Automatic Fire Detection*  
Data Sheet 7-14, *Fire Protection for Chemical Plants*  
Data Sheet 7-93, *Aircraft Hangars*  
Data Sheet 8-1, *Commodity Classification*  
Data Sheet 8-9, *Storage of Class 1, 2, 3, 4 and Plastic Commodities*  
Data Sheet 9-1, *Supervision of Property*  
Data Sheet 9-18, *Protection Against Freeze-Ups*  
Data Sheet 10-3, *Hot Work Management*

The *Approval Guide*, an online resource of FM Approvals

### 4.2 Other

#### 4.2.1 American Welding Society (AWS)

AWS B2.1, *Specification for Welding Procedure and Performance Qualification*.

#### 4.2.2 American Society for Testing and Materials (ASTM)

ASTM A.17.1, *Safety Code for Elevators and Escalators*.

ASTM E84, *Standard Test Method for Surface Burning Characteristics of Building Materials*.

ASTM E136, *Standard Test Method for Behavior of Materials in a Vertical Tube Furnace at 750°C*.

## APPENDIX A GLOSSARY OF TERMS

**Accelerator:** A quick-opening device, typically installed on the dry-pipe valve of a dry-pipe system, that is used to reduce the time it takes a water control valve (such as a dry-pipe valve) to open. It works by reducing the pressure differential across the clapper of the water control valve.

**Acceptance test:** A test conducted on the sprinkler system, or a specific portion of the sprinkler system, to ensure that it will function to the satisfaction of the authority having jurisdiction.

**Actuating component:** Any component of a sprinkler system that is used to actuate the system's automatic water control valve. An example would be an accelerator for a dry-pipe valve.

**Alarm check valve:** A check valve, typically installed on the riser of a sprinkler system, that is specifically designed to allow a means of alarm notification when waterflows through it.

**Anti-flooding device:** A component of an accelerator that prevents the introduction of water or foreign matter from entering the accelerator.

**Antifreeze solution sprinkler system:** A sprinkler system in which the media within the sprinkler system consists of a combined antifreeze and water solution.

**Approval Guide:** An online publication of FM Approvals that provides a guide to equipment, materials, and services FM Approved for property conservation ([www.approvalguide.com](http://www.approvalguide.com)).

**Area spacing:** The portion of the protected area that is protected by an individual sprinkler. It is calculated using the following equation:

$$\text{Area spacing} = (S) \times (L), \text{ ft}^2 (\text{m}^2)$$

Where:

S is the linear distance from one sprinkler to the nearest sprinkler installed on the same branch line.

L is the linear distance from one sprinkler to the nearest sprinkler installed on an adjacent branch line.

**Arm-over:** A combination of piping and fittings (typically elbows) that connects the branch line to a sprinkler that is positioned horizontally away from the branch line.

**Authority having jurisdiction (AHJ):** The person, or persons, responsible for enforcing the guidelines in this data sheet. For FM purposes, the AHJ is the appointed Field Engineering representative from the applicable Operations Center.

**Automatic sprinkler:** A piece of fire protection equipment through which water is automatically discharged with the intent of either controlling or suppressing a fire. A sprinkler typically consists of four main components: the sprinkler frame, the orifice cap, the thermal sensing element, and the deflector. Note that the orifice cap and the thermal sensing element components are provided on closed-type sprinklers but are removed from open-type or deluge system sprinklers.

**Automatic sprinkler deflector:** The component of a sprinkler that redirects the water discharged through the orifice toward the protected area.

**Automatic sprinkler frame:** The component of a sprinkler that is connected to the sprinkler piping and contains the sprinkler orifice.

**Automatic sprinkler frame arm:** The component of a sprinkler frame that is used to connect the sprinkler deflector to the sprinkler a given distance away from the sprinkler orifice.

**Automatic sprinkler orifice:** A component of a sprinkler located on the sprinkler frame through which water is discharged.

**Automatic sprinkler system:** An integrated network of above-ground piping to which sprinklers are attached. At a minimum each sprinkler system is provided with at least one system control valve, system pressure gauge, system drain valve and a means of initiating alarm notification in the event of water movement through the system's piping network. A sprinkler system is considered to provide "Adequate" protection if it is connected to a reliable automatic water supply that can provide the flow, pressure and duration requirements for all occupancy hazards protected by the sprinkler system as required by the occupancy-specific data sheet.

**Automatic sprinkler system hydraulic calculations:** A set of calculations that indicates the flow and pressure required at a given reference point on the sprinkler system (base of riser) to satisfy the required design of the sprinkler system.

**Automatic sprinkler temperature rating:** The temperature at which the thermal sensing element of the sprinkler operates. See Table 2.5.1.1.1 for the nominal temperature ratings of sprinklers.

**Automatic sprinkler thermal sensing element:** The component of a sprinkler that, when subjected to the influence of heat, weakens to the point where pressure acting on the orifice cap will cause it to dislodge, thus allowing water to flow from the sprinkler.

**Automatic system valve:** Automatic system valves hold back water from entering a preaction, deluge or similar type sprinkler system until the valves are automatically released by a system of electrical, pneumatic, or hydraulic signaling and releasing devices. These valves are usually single or multiple clapper valves, with the clappers held on their seats by a series of latches and levers or by differential water pressure.

**Back drainage:** Water that can collect above the seat of a water control valve after the closure of the sprinkler system's main drain valve.

**Bar joist chord:** Also known as the flange of a bar joist, it is the top and bottom parts of a bar joist that support the web of the joist. It typically consists of two angle irons installed back-to-back.

**Base of riser:** A reference point on a sprinkler system at which the hydraulic analysis of the sprinkler system demand, as well as the water supply available for the sprinkler system, is analyzed. This reference point is typically at floor level just prior to the sprinkler system's control valve.

**Belt-type conveyor:** A conveying system that uses typically a solid rubber belt to move products from one area of a facility to another area. These types of conveying systems can be an obstruction to sprinkler discharge depending on how wide the belt is. See Section 2.5.2.5.9 for Nonstorage sprinklers or Section 2.5.4.5.9 for Storage sprinklers for additional information.

**Blocked flue space:** A flue space that is either (a) not vertically aligned, or (b) too narrow to allow heat to travel up through it in a timely fashion. A blocked flue space can allow for unacceptable fire growth below it to take place by promoting horizontal fire spread and preventing sprinkler discharge from reaching the vertical surfaces of the burning commodity.

**Boards on joists:** Construction that consists of wooden ceiling or floor decking that is supported by closely spaced wooden joists (typically nominal 2 in. x 4 in. or larger joists).

**Branch line:** The piping network of a sprinkler system that provides water to a sprinkler or sprinkler assembly.

**Bridging:** A structural building member, typically steel angle iron, that is attached perpendicular to the bottom chords of bar joists to provide increased lateral resistance to wind forces acting on the roof.

**Burrs (or fins):** Protrusions, also referred to as "rough edges," from a sprinkler pipe that need to be removed before the pipe is connected to another piece of the sprinkler system.

**Butt-welded:** A connection process by which the ends of two pieces of sprinkler pipe are joined together by an acceptable welding means without the pipe ends overlapping.

**Bypass test connection:** An assembly consisting of pipe, a check valve (if necessary), and a manually operated 90° turn valve that is connected to the supply side of the sprinkler system's system valve (i.e., alarm check, dry-pipe, preaction or deluge valve) and arranged to activate a waterflow device that is connected to the sprinkler system's system valve. Its purpose is to allow testing of the sprinkler system's waterflow alarm without having to flow water past the system valve.

**Ceiling channel:** A portion of the ceiling that is bounded by solid or semi-solid (less than 70% open) structural members, such as purlins, girders, concrete tees, I-beams, etc., having a vertical depth greater than 4 in. (100 mm). The boundaries of the ceiling channel are defined by the structural members that are attached to the underside of the ceiling leaving a maximum vertical gap of 4 in. (100 mm) between the underside of the ceiling and the topside of the structural member.

**Ceiling pocket:** An architectural ceiling feature that consists of a bounded area of ceiling located at a higher elevation than the attached lower ceiling.

**Ceiling slope:** The measured angle created by the rise in ceiling height relative to the floor. Ceiling slope in this data sheet is provided in both pitch and degrees.

**Channel bay:** The space created by the primary and secondary structural ceiling members.

**Channel-blocking:** A method of trapping heat from a fire within a given volume of obstructed ceiling construction by using a material having fire-resistant construction equal to or higher than the materials that frame the obstructed ceiling construction. The channel-blocking is installed perpendicular to, and the full depth of, the ceiling structural members that created the obstructed ceiling construction.

**Check valve:** A valve with an inherent design characteristic that permits flow of water in one direction and prevents waterflow in the opposite direction under cyclic pressure conditions.

**Chemical/resin anchor:** A means of installing load supporting anchors into concrete using epoxies or similar chemicals.

**Class 1 construction:** Wall and ceiling construction that consists of materials that contribute limited quantities of fuel when exposed to fire. This includes FM Approved Class 1 wall, ceiling or roofing assemblies including fire retardant treated lumber. Non-plastic ceiling tiles that have a flame spread index (FSI) less than or equal to 25, based on testing per ASTM E84, Standard Test Method for Surface Burning Characteristics of Building Materials, may be considered limited combustible for sprinkler protection purposes.

**Collateral load:** Dead loads created by the weight of objects hung from the underside of a roof or ceiling, such as piping, ductwork, equipment, etc.

**Combustible construction:** Wall and/or ceiling construction that cannot be classified as either noncombustible construction or limited-combustible construction and could result in a self-propagating fire. Such construction warrants the provision of sprinkler protection.

**Combustible occupancy:** An occupancy that contains sufficient combustible materials within to allow horizontal spread throughout a given area in the absence of sprinkler protection; or an occupancy that contains a sufficient concentration of combustibles that could cause significant damage to the building structure or flashover in the absence of sprinklers.

**Combustible solid structural members:** Ceiling structural members that are void of openings but do not comply with ASTM E136, Standard Test Method for Behavior of Materials in a Vertical Tube Furnace at 750°C.

**Concealed automatic sprinkler:** A sprinkler that is installed under a flat, smooth ceiling, and the entire body of the sprinkler, including the operating mechanisms, is above a concealing plate, the margin of which is nearly flush to the ceiling surface.

**Concrete tee construction:** Ceiling or floor construction consisting of pretensioned concrete in the form of the letter T. See Figure A-1 for an example of a double-tee concrete slab.

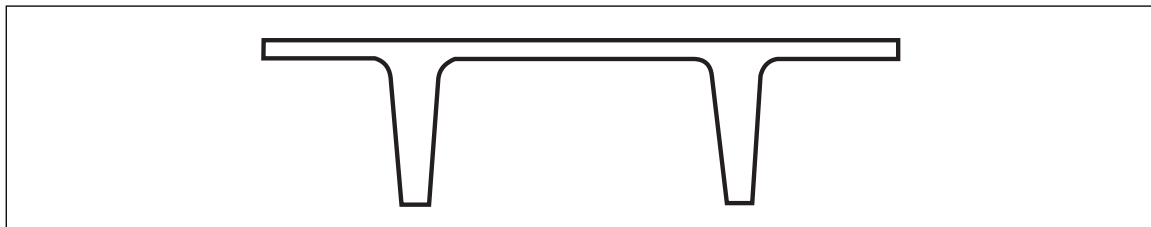

*Fig. A-1. Example of a double-tee concrete slab*

**Continuous object:** A continuous object, for obstruction evaluation purposes, is one that has a horizontal length that is greater than one half of the maximum allowable horizontal linear spacing of the ceiling-level sprinklers.

**Control valve:** A manually operated fire service valve, typically of the gate or butterfly type, that controls the water supply to a sprinkler system.

**Conventional automatic sprinkler:** A sprinkler that has similar components compared to a standard-spray sprinkler, except that its deflector is designed to discharge 40% or more of its water in an upward trajectory.

**Corrosive environment:** An environment that would cause corrosive damage to metallic components of a sprinkler system.

**Coupling:** A coupling is a fitting that is used to join two or more sprinkler system components together.

**Coupon:** The cut-out (disc) portion of a sprinkler pipe that is removed (typically from a welded sprinkler system) for creating an outlet in the pipe.

**CPVC pipe:** Chlorinated poly vinyl chloride (CPVC) is used to produce a type of plastic sprinkler pipe.

**Cross main:** The piping network of a tree-type sprinkler system that provides water to the branch lines.

**C-shaped steel secondary roof member (purlin):** A thin, usually 0.058 to 0.120 in. (1.5 to 3.0 mm) thick, solid web, cold-formed steel secondary member (directly supports deck) that is formed in the shape of the letter C. It usually varies in depth from 8 to 11.5 in. (200 to 290 mm) but may range from 6.5 to 14.5 in. (165 to 368 mm). See Data Sheet 1-31, *Metal Roof Systems*, for further details.

**Damage-limiting construction:** A type of construction that consists of both pressure-resistant and pressure-relieving ceiling and/or walls that allows the internal pressure building-up from a deflagration type of explosion to release safely to a designated external area. See Data Sheet 1-44, *Damage-Limiting Construction*, for further details.

**Darcy-Weisbach method:** A method of calculating friction loss within a sprinkler system that is based on a given internal pipe diameter, the average velocity of the liquid moving through the pipe, the material make-up of the pipe, and the viscosity of the liquid moving through the pipe. Although it can be used for any sprinkler system hydraulic analysis, it should be used for any sprinkler system that is not water-based or any sprinkler system where the waterflow velocity exceeds 30 ft/s (9.1 m/s).

**Data sheet (FM Property Loss Prevention Data Sheet):** Engineering guidelines for a given subject matter that are written to help reduce the chance of property loss due to fire, natural hazards, and failure of electrical or mechanical equipment, and incorporate loss experience, research results, input from consensus standards committees, equipment manufacturers and others.

**Dead load:** Loads consisting of the weights of all materials of construction, building finishes, and fixed service equipment. In the case of green roof systems, the entire roof assembly (including growth media, roofing materials, and captured water) is considered dead load.

**Deluge sprinkler system:** A sprinkler system that is located downstream of a deluge valve and is equipped with open-type sprinklers (i.e., sprinklers where the thermal sensing element and the orifice cap have been removed).

**Deluge valve:** An automatic water control valve, typically installed on a sprinkler system riser, specifically designed to hold back water from passing through it until certain conditions have been met. It is typically connected to an automatic detection system that, once activated, opens the valve, and allows water to flow through it. It is connected upstream of a deluge sprinkler system.

**Demand area:** The expected area of sprinkler operation, based on the commodity hazard being protected, used for hydraulic design purposes. It may also be referred to as the "design area".

**Design area:** The expected area of sprinkler operation, based on the commodity hazard being protected, used for hydraulic design purposes. It may also be referred to as the "demand area".

**Double-interlock preaction system:** A sprinkler system that is located downstream of a preaction valve and is equipped with closed-type sprinklers. The preaction valve is arranged to open only when a sprinkler has operated and the detection system supervising the area being protected by the preaction sprinkler system has activated. Most double-interlock sprinkler systems have either electric or pneumatic means of accomplishing these two activating conditions.

**Draft curtain:** Also referred to as a curtain board, a draft curtain is a solid continuous material that is installed perpendicular to a ceiling with the intent of preventing the flow of hot gases from a fire from traveling horizontally beyond the curtain. Draft curtains are typically not recommended for buildings equipped with sprinkler protection except where specifically required in either this standard or an occupancy-specific data sheet.

**Drain valve:** A manually operated valve and pipe assembly, typically 2 in. (50 mm) in size and located on the sprinkler system riser, that is used for draining water out of the sprinkler system and verification of waterflow at the riser.

**Drop nipple:** The piece of pipe that connects the branch line to a sprinkler located directly below the branch line.

**Dry inert gas supply:** The gaseous medium used in a dry-pipe, preaction or similar sprinkler system. It needs to be void of substances, such as water, that could interact with the inner walls of the sprinkler piping, leading to corrosion of the sprinkler piping and/or potential build-up of solids, such as ice or rust, which could cause blockage of waterflow to sprinklers during a fire condition. An example would be an FM Approved nitrogen generator. For sprinkler systems provided with air, either:

- A. Use an FM Approved air supply package, or
- B. Use a regenerative air dryer that can dehumidify the air to a pressure dew point that is 20°F (11°C) lower than the nominal ambient temperature of the area protected by the sprinkler system.

**Dry-pendent automatic sprinkler:** A dry-type sprinkler where the sprinkler attached to the extension nipple is of the pendent orientation. These types of sprinklers are typically used to protect areas subject to freezing and are connected to water-filled sprinkler piping located above the protected area in an area provided with sufficient heat. They are also sometimes used on dry type sprinkler systems where the installed sprinkler must be of the pendent orientation.

**Dry-pipe sprinkler system:** A sprinkler system that is located downstream of a dry-pipe valve. It is filled with a pressurized gaseous medium (typically air or an inert gas such as nitrogen) for maintaining the dry-pipe valve closed. Upon sprinkler actuation, the pressure within the sprinkler system begins to drop until the pressure becomes too low to keep the dry-pipe valve closed. At this time, the dry-pipe valve opens (trips) allowing water to fill the sprinkler system and discharge through any sprinklers that have been actuated. A dry-pipe sprinkler system is typically used in areas where the presence of water within the sprinkler system is not suitable.

**Dry-pipe valve:** An automatic water control valve, typically installed on the riser of a sprinkler system, that is specifically designed to use a pressurized gaseous medium (typically air or an inert gas such as nitrogen) to hold back water on the upstream side of the valve. The valve remains closed until the gas pressure on the downstream side of the valve drops, such as by sprinkler operation, to a value too low to hold back the pressure of the water, thus opening the valve and allowing water to flow into and fill up the dry-pipe sprinkler system. Like an alarm check valve, it is designed to be equipped with a means of alarm notification in the event water flows through it, but it is also equipped with a means of measuring the gas pressure within the sprinkler system and provide an alarm in the event of low-pressure condition.

**Dry-sidewall automatic sprinkler:** A dry-type sprinkler where the sprinkler attached to the extension nipple is of the sidewall orientation.

**Dry-type automatic sprinkler:** A sprinkler assembly that consists of a sprinkler and an extension nipple to which the sprinkler has been permanently connected to. The extension nipple is equipped with a closure at the inlet end that prevents water from entering the nipple until the sprinkler operates.

**Dry-upright automatic sprinkler:** A dry-type sprinkler where the sprinkler attached to the extension nipple is of the upright orientation. These types of sprinklers are typically used to protect areas subject to freezing and are connected to water-filled sprinkler piping located below the protected area in an area provided with sufficient heat.

**Earthquake zone designation:** FM Earthquake Zones are based on the 50-year, 100-year, 250-year, 500-year, and >500-year earthquake ground shaking recurrence intervals. See Data Sheet 1-2, *Earthquakes*, for clarification of these designations and the earthquake map that applies to a given geographical area.

**Effective point of water supply test:** This is a reference point within the water supply's piping network at which the results of a water supply test are applicable. This reference point is determined by starting at the pressure gauge where the static and residual pressure readings are taken during the water supply test. During the test there is no flowing water at this gauge. The next step is to travel a path from the pressure gauge back upstream through the piping network toward the source for the water supply. The Effective Point is the point in the water supply piping network where flowing water from the test meets non-flowing water that supplies pressure to the pressure gauge used for reading both the static and residual pressures during the test. If there is any elevation difference between the pressure gauge and the Effective Point, it must then be accounted for in both the static and residual pressures obtained during the test.

**End wall:** The nearest wall, which is generally at a 90° angle to the sprinkler's deflector and not behind it, to a sidewall sprinkler.

**Equivalent length:** A measurement used in hydraulic calculations to represent the pressure loss through a sprinkler system fitting. The length indicated represents a section of pipe that would have the same friction loss through it that occurs through the fitting.

**Exhauster:** A quick-opening device, typically installed within the piping network of a dry-pipe sprinkler, that was installed with the intention of reducing the time it takes a water control valve (such as a dry-pipe valve) to open. It works by venting the gaseous medium within the sprinkler system to atmosphere. Exhausters are no longer recommended for installation as a quick-opening device due to their frequency of becoming plugged during operation.

**Expansion anchor:** A hanger that is inserted into a self-drilled or predrilled hole in concrete and then “set”, usually by tightening of a bolt, setting of a cam or semi-soft member, or forced expansion over a hardened steel plug.

**Explosive-driven fastener:** Fasteners that are used in either the vertical or horizontal plane to attach sprinkler pipe hanger rods to structural steel or concrete. The fasteners are imbedded into the supporting structure under high-pressure via a powder-actuated tool.

**Exposure-protection sprinkler system:** A sprinkler system that is specifically designed to protect a building or an object from a fire that originates remotely from the building or object being protected.

**Extended coverage automatic sprinkler:** A sprinkler where the area of coverage exceeds that given for a standard sprinkler based on the occupancy being protected.

**Far main:** The piping network of a grid-type sprinkler system that is connected to the branch lines on the side opposite from the near main.

**Feed main:** The piping network of a sprinkler system that connects the sprinkler system riser to the main(s) that feeds the branch lines.

**Ferrous material:** A material that consists mainly of iron.

**Fire control:** A condition in which equilibrium has been achieved between burning commodity and sprinkler system discharge such that ceiling level temperatures do not increase, and horizontal fire spread has been eliminated.

**Fire service connection:** A device, consisting of at least one outlet and a check valve, that connects to the sprinkler system and provides a means for the fire service to pump water into the sprinkler system from a public hydrant or other available water supply.

**Fire extinguishment:** A condition in which the temperature of all surfaces of a burning commodity has been lowered below the commodity's fire point.

**Fire suppression:** The conditions for fire control have been met and fire on most of the vertical surfaces of burning commodities has been extinguished resulting in a significant reduction in the fire's heat release rate.

**Fitting:** A sprinkler system piping-related product that is manufactured to standardized dimensions. These dimensions may exist in Industry Standards or be based on those of manufacturers that have been accepted by the market as the “norm”.

**Flame detection:** Detection that is sensitive to infrared, visible, or ultraviolet radiation produced by a fire, or to specific ranges of radiation that are modulated at characteristic flame flicker frequencies. Flame detectors are essentially line-of-sight devices and are usually designed to respond to a fire within the detector's cone of vision in approximately one second or less. Typical flame detectors include infrared, ultraviolet, photoelectric and flame-flicker. See Data Sheet 5-48, Automatic Fire Detection, for more information regarding these types of detectors and the type of fire hazard they are appropriate for.

**Flashover:** The near-simultaneous ignition of all exposed combustible materials in a room or an area from floor to ceiling caused by thermal radiation feedback.

**Flat, continuous, false ceiling:** A solid continuous sub-ceiling that is installed parallel to floor level at a given vertical distance below the primary ceiling or roof with sprinklers installed below it as recommended per the applicable section of this data sheet. The purpose of a false ceiling in combination with sprinklers below it is to typically address hazards that can negatively affect ceiling-level sprinkler performance, such as excessive clearance, excessive airflow velocities, excessive ceiling slope or loss of the heat plume through exhaust openings at ceiling level.

**Flat smooth ceiling construction:** A ceiling construction that is void of undulations, indentations or projections and is installed parallel to the floor.

**Flat, solid, horizontal barrier:** A barrier that can be installed below an object that is considered an unacceptable obstruction to the discharge pattern of a ceiling-level sprinkler. The barrier, which has the same footprint size as the obstructing object, is installed on a horizontal plane either parallel to the floor, or parallel to the underside of a non-flat or non-solid object, under which supplemental sprinklers are provided.

**Flue space:** A vertical space located between two adjacent commodities that are being maintained in a storage arrangement.

**Flush automatic sprinkler:** A sprinkler in which essentially all the body, except for the thermal sensing element, is mounted above the lower plane of a ceiling.

**Flushing:** The practice of flowing water or pneumatically blowing through a fire protection piping system for removing obstructions.

**Flushing connection:** A pipe extension on the end of a cross main that consists of either a threaded capped nipple (see Figure A-2) or an FM Approved mechanical groove coupling with a blank flange inside the coupling. The diameter of the flushing connection is typically between 1.25 in. (32 mm) and 2 in. (50 mm).

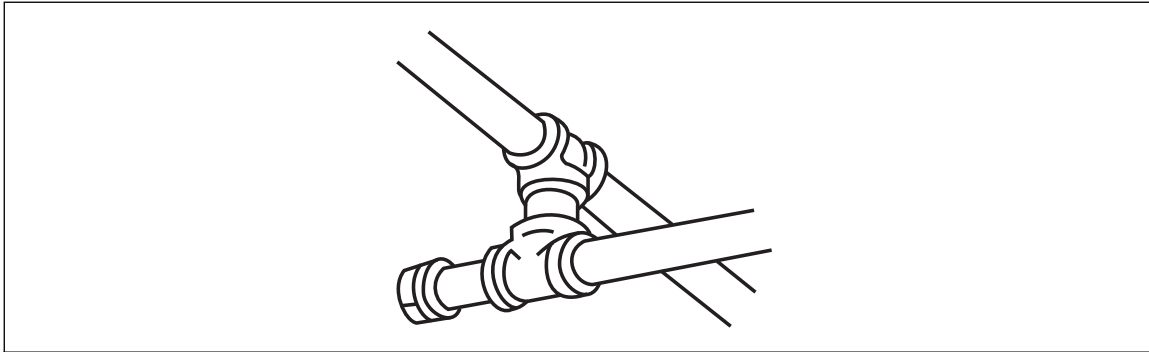

Fig. A-2. Example of a flushing connection with a threaded end cap

**FM Approved:** A product that has been tested to and meets the requirements of a specific Approval Standard and has been listed in the *Approval Guide*, an online resource of FM Approvals.

**Gravity heat/smoke vent:** A device installed at ceiling level that is designed to allow heat and/or smoke, released during a fire event, to escape through it without the assistance of any mechanical means (such as operating fans). As a result, they act like a natural draft exhaust vent but are equipped with a cover that can open either automatically or manually. They are commonly arranged for automatic operation. When such devices are arranged for automatic operation mode (manual operation mode is recommended) they are not recommended for buildings equipped with sprinkler protection.

**Grid-type sprinkler system:** A sprinkler system in which the network of branch lines is connected to at least two mains (typically a near main and a far main) thus allowing waterflow to any operating sprinklers within the grid to be from at least two directions.

**Grouped obstruction:** Two or more adjacent objects that are collectively considered one object (i.e., grouped obstruction) for obstruction evaluation purposes.

**Grooved pipe:** A piece of sprinkler piping in which at least one of the ends of the pipe has been fabricated with an acceptable standardized groove (cut or rolled) to allow the pipe to be connected to another sprinkler piping via a grooved coupling or fitting.

**Hanging and bracing pipe support:** A mechanical assembly consisting of a fastener, an intermediate connecting component (threaded steel rod or similar), and a hanger used for supporting sprinkler piping from a building structure.

**Hazen-Williams method:** A method of calculating friction loss within a sprinkler system that is based on a given waterflow rate, internal pipe diameter, and internal pipe roughness coefficient. It can be used for the

calculation of friction loss through a water-based sprinkler system having waterflow velocities not exceeding 30 ft/s (9.0 m/s). See Data Sheet 3-0, *Hydraulics of Fire Protection Systems*, for more information on this hydraulic calculation method.

**Highest hazard commodity:** For commodities maintained in a storage arrangement, the commodity that is expected to release the highest amount of heat within a fixed timeframe. FM recommends that a sprinkler system be capable of protecting a storage arrangement based on the commodity that is considered the highest hazard.

**High-temperature environment:** An environment where the ambient temperature is expected to rise above 200°F (95°C).

**Horizontal sidewall automatic sprinkler:** A sidewall-type sprinkler where the sprinkler orifice is in a horizontal plane relative to the protected area.

**Indicating control valve:** A manually operated valve installed within a sprinkler system that, when shut, prevents the flow of water downstream of it. The valve is equipped with a visual means of determining whether the valve is open or closed.

**Individual obstruction:** An object that is separated from adjacent objects by a sufficient distance thus allowing the object to be evaluated for obstruction purposes without considering the presence of any adjacent objects.

**In-rack automatic sprinkler:** A sprinkler that is installed within a storage rack. Also referred to as “rack storage” or “intermediate level” sprinklers.

**Insert:** A fastener that is driven vertically into a concrete structural member to provide anchorage for a supporting pipe hanger.

**Inspector’s test connection:** A device used to test the waterflow alarm mechanism provided for the sprinkler system. It is typically installed at the hydraulically remote end of a sprinkler system and consists of a manual control valve, a section of sprinkler piping (allowing discharge to a safe location), and a smooth bore corrosion-resistant orifice (no larger than the smallest orifice of any sprinkler installed on the sprinkler system to which the Inspector’s Test Connection serves). Depending on the water delivery time design of the sprinkler system it may include one, two or even four outlets.

**Interlock:** The arrangement of normal operating functions, such as room air flow or conveyor-belt operation, to be either interrupted or altered in the event of a sprinkler system’s alarm condition.

**Intermediate chamber:** The space formed within a dry-pipe valve between the air and water clappers, or between the two seat rings in a single clapper design. This chamber is vented to atmosphere through an automatic drain valve when the valve is in its normally shut or “set” position. This chamber allows any water or air leakage by the clapper(s) to be detected. When the dry-pipe valve operates or “trips,” water enters this chamber, the automatic drain valve shuts, and water flows to the alarms associated with the dry-pipe system as well as into the sprinkler system piping.

**Internal steel pipe resistant to oxidation:** Steel sprinkler pipe that either by itself (i.e., stainless steel, etc.) or via an internal coating (i.e., galvanized, etc.) is designed to limit the amount of oxidation that might take place within a sprinkler system that is not normally filled with a liquid medium (i.e., water, antifreeze, etc.).

**Internally galvanized:** Sprinkler pipe that has been coated internally with a layer of zinc for preventing the oxidation of the pipe.

**K-factor:** Also known as the discharge coefficient, it is a numerical value representing the orifice size of the sprinkler in combination with the expected flow through the sprinkler orifice at a given pressure value. It is calculated using the following equation:

$$K = \frac{Q}{\sqrt{P}}$$

Where: Q is the flow through the sprinkler orifice in gpm (Lpm).  
P is the pressure at the sprinkler orifice in psi (bar).  
The units for K are gpm/psi<sup>0.5</sup> (Lpm/bar<sup>0.5</sup>).

**Lightweight concrete:** Concrete that has a unit weight less than 115 lb/ft<sup>3</sup> (1,840 kg/m<sup>3</sup>).

**Limited-combustible construction:** Wall and ceiling construction that consists of materials that contribute limited quantities of fuel when exposed to fire, but in the form they will be installed will not propagate a fire. This includes FM Approved Class 1 wall, ceiling or roofing assemblies including fire retardant treated lumber. Non-plastic ceiling tiles that have a flame spread index (FSI) less than or equal to 25, based on testing per ASTM E84, Standard Test Method for Surface Burning Characteristics of Building Materials, may be considered limited combustible for sprinkler protection purposes.

**Linear spacing:** The horizontal distance between sprinklers as measured relative to the protected area.

**Line-type detection:** Detection that is continuous along a given path. See Data Sheet 5-48, *Automatic Fire Detection*, for more information regarding these types of detectors and the type of fire hazard they are appropriate for.

**Live load:** Variable loads produced by the use and occupancy during the life of the structure. Live loads on a roof include those loads produced by people, moveable maintenance materials and equipment, and other moveable objects.

**Load-supporting test:** A test conducted on the supporting systems of sprinkler piping to ensure they have been properly installed and can support the anticipated load of the liquid-filled pipe.

**Longitudinal flue spaces:** A vertical space, located between materials maintained in a storage arrangement, that is parallel to the loading aisle. Such flue spaces are typically found in storage racks.

**Low-temperature environment:** An environment where the ambient temperature is expected to drop below 40°F (4°C).

**Mechanical exhaust vent:** A device installed at ceiling level that is designed to remove air from the area below the vent by mechanical means, such as a powered fan.

**Mechanically-operated heat/smoke vent:** A device installed at ceiling level that is designed to allow heat and/or smoke, released during a fire event, to escape through it with the assistance of mechanical means (such as operating fans). They are commonly arranged for automatic operation. When such devices are arranged for automatic operation mode (manual operation mode is recommended) they are not recommended for buildings equipped with sprinkler protection.

**Most remote sprinkler:** The sprinkler on a sprinkler system that would have the least amount of pressure available to it in the event all sprinklers were discharging water simultaneously.

**Mounting wall:** The wall on which a sidewall sprinkler has been installed.

**Natural draft exhaust vent:** A device installed at ceiling level that is designed to remove air from the area below the vent by natural draft.

**Near main:** The piping network of a grid-type sprinkler system that is connected to the feed main and provides water to the branch lines.

**Nitrogen generator:** A mechanical device that is typically connected to either a dry-pipe or pre-action sprinkler system that produces pressurized nitrogen within the sprinkler system's piping network to minimize interior sprinkler pipe corrosion.

**Node:** A point provided on a sprinkler system working drawing for hydraulic calculation purposes. It is provided to represent any sprinkler that is expected to operate during a fire, a change in internal pipe diameter, a change in pipe roughness, a change in the flow rate, or a point needed for reference (the base of the riser).

**Nominal temperature rating:** A description of a temperature rating that covers a small range of fixed temperatures for the thermal element of a sprinkler. For example, a nominal temperature rating of 160°F (70°C) typically represents sprinklers having an actual temperature rating between 155°F (68°C) and 165°F (74°C). The range for a nominal temperature rating is typically about +/-4% of the indicated value.

**Noncombustible construction:** Wall and ceiling construction that consists of materials that do not contribute significant quantities of fuel when exposed to fire. This includes an FM Approved Class 1, Noncombustible Core Metal Panel or Class 1 Insulated Steel Deck Roof Assembly with noncombustible insulation. Any material or assembly that passes ASTM E136, Standard Test Method for Behavior of Materials in a Vertical Tube Furnace at 750°C, such as concrete, brick, glass-faced or unfaced gypsum panels, can also be categorized as noncombustible. While paper-faced gypsum marginally fails ASTM E136, it can be treated as noncombustible for sprinkler protection purposes.

**Noncombustible solid structural members:** Ceiling structural members that are void of openings and comply with ASTM E136, Standard Test Method for Behavior of Materials in a Vertical Tube Furnace at 750°C.

**Non-continuous object:** A non-continuous object, for obstruction evaluation purposes, is one that has a maximum horizontal length that is less than or equal to one half of the maximum allowable horizontal linear spacing of the ceiling-level sprinklers.

**Non-interlock preaction system:** A sprinkler system that is located downstream of a preaction valve and is equipped with closed-type sprinklers. The preaction valve is arranged to open upon either the operation of a sprinkler or the actuation of a detection system that is supervising the area being protected by the preaction sprinkler system.

**Non-potable water supply:** A water supply that is not safe for human consumption as described by the public health authority having jurisdiction.

**Non-smooth ceiling construction:** A ceiling construction that is not void of undulations, indentations, or projections.

**Nonstorage automatic sprinkler:** A sprinkler that has been categorized by FM as acceptable for protecting nonstorage-type occupancies and/or any other low to moderate heat-release type fires as permitted in an occupancy-specific data sheet.

**Nonstorage-type occupancy:** An occupancy consisting of combustible or noncombustible materials that are not maintained in a storage arrangement.

**Obstructed ceiling construction:** A ceiling structural assembly that prevents the flow of hot gases from spreading out under the ceiling in a uniform fashion from the point of fire origin, when centered within a ceiling channel, to the nearest four sprinklers. Examples of ceilings that meet this definition include solid or semi-solid (less than 70% open) structural members, such as purlins, girders, concrete tees, I-beams, etc., that have a vertical depth greater than 4 in. (100 mm) and the horizontal distance between structural members is less than or equal to the minimum allowable linear spacing for the sprinkler being installed.

**Occupancy-specific data sheet:** A data sheet that addresses a specific occupancy hazard. The data sheets are categorized into one of fifteen series covering the following subjects:

- Series 1 data sheets – Construction Guidelines
- Series 2 data sheets – Sprinkler and Sprinkler System Installation Guidelines
- Series 3 data sheets – Water Supply Guidelines and Design Guidelines of most nonstorage type occupancies
- Series 4 data sheets – Guidelines for Protection Systems other than Sprinklers
- Series 5 data sheets – Electrical Guidelines
- Series 6 data sheets – Boilers and Industrial Heating Equipment Guidelines
- Series 7 data sheets – Guidelines for Occupancies that are considered Special Hazards
- Series 8 data sheets – Storage Protection Guidelines
- Series 9 data sheets – Property Protection Guidelines and Miscellaneous Information
- Series 10 data sheets – Human Factor Guidelines
- Series 11 data sheets – Systems Instrumentation and Control Guidelines
- Series 12 data sheets – Pressure Vessel Guidelines
- Series 13 data sheets – Mechanical Guidelines
- Series 15 data sheets – Welding Guidelines
- Series 17 data sheets – Miscellaneous Boiler and Machinery Guidelines

**Old-style automatic sprinkler:** A sprinkler that was manufactured prior to 1953. These sprinklers were designed to discharge 40% to 60% of their water upwards to extinguish any fire that might be at ceiling level.

**One-piece reducing fitting:** A fitting that connects two pipes of different diameter.

**Open-grid ceiling:** A ceiling that is installed between the sprinklers installed under a solid ceiling and the protected occupancy that consists of uniform openings that constitute at least 70% of the ceiling area.

**Open-grid mezzanine:** A mezzanine that consists of uniform openings that constitute at least 70% of the mezzanine area.

**Open-grid walkway:** A walkway that consists of uniform openings that constitute at least 70% of the walkway area.

**Opposing wall:** The wall located directly across the room from the wall on which a sidewall sprinkler has been installed.

**Orientation:** A description of a sprinkler's deflector relative to the protected area. Terms describing the orientation of a sprinkler include pendent, sidewall or upright.

**Orifice cap:** A component of a closed-type sprinkler that is placed over the sprinkler orifice and prevents water from discharging through it until the thermal sensing element of the sprinkler has been activated.

**Pendent automatic sprinkler:** A sprinkler where the water discharge from the sprinkler orifice is directed vertically downward toward the deflector, which in turn directs the water downwards toward the protected area. The sprinkler is designed to have the deflector oriented vertically below the pipe to which the sprinkler is connected.

**Pipe hanger:** A pipe support component that attaches to the sprinkler pipe.

**Pipe hanger fastener:** A pipe support component, such as an anchor, expansion shield, concrete insert, explosive-driven fastener, or a threaded head screw, installed in the vertical position that provides anchorage into the building structure.

**Pipe roughness (C factor):** The measure of resistance the internal walls of a pipe offer to the flow of liquid through the pipe. The value is used in friction loss calculations as part of the hydraulic calculations of a sprinkler system.

**Pitch:** The measured angle created by the rise in sprinkler pipe or ceiling relative to the floor.

**Plain-end pipe:** A piece of sprinkler piping in which at least one of the ends of the pipe has not been fabricated. The connection of this type of pipe to another piece of sprinkler pipe is via a fitting specifically design for plain-end type pipe.

**Plastic skylight:** A roof opening that is covered with a translucent plastic, designed to allow daylight into the area located below the roof opening.

**Point load:** A single load value that represents the total weight transferred to the building structure at the point of connection.

**Potable water supply:** A water supply that is safe for human consumption as described by the public health authority having jurisdiction.

**Powder-actuated tool:** A special device that is used to imbed explosive-driven fasteners into either structural steel or concrete.

**Powder-actuated fastener system (PAFS):** A fastening system consisting of a tool, powder cartridge, and fastener. The tool drives the fastener into the point of attachment using the explosive cartridge.

**Preaction sprinkler system:** A sprinkler system that is located downstream of a preaction valve and is equipped with closed-type sprinklers (i.e., sprinklers equipped with a thermal sensing element and an orifice cap). The different types of preaction sprinkler systems include preaction, deluge, refrigerated-area and vacuum sprinkler systems and can be arranged for non-interlock, single-interlock, or double-interlock activation methods.

**Preaction valve:** An automatic water control valve, typically installed on a sprinkler system riser, specifically designed to hold back water from passing through it until certain conditions have been met, such as activation of a detection system supervising the area protected by the preaction sprinkler system or by pressure drop downstream of the valve. It is connected upstream of a preaction sprinkler system.

**Pressure gauge:** A device installed on a sprinkler system that measures the pressure of the water, or other media within the sprinkler system, acting on the internal walls of the sprinkler piping.

**Pressure reducing valve:** An automatic device that is installed within a sprinkler system and is used to control the water pressure within the sprinkler system downstream of it to a pre-set acceptable level. They may be either direct acting, which are operated automatically by inner hydraulic controls, or pilot-operated diaphragm type globe valves.

**Pressure relief valve:** An automatic operating valve that will react rapidly to pressure buildup within a sprinkler system and relieve the pressure to atmosphere. The goal of the device is to maintain the internal pressure of a sprinkler system at or below a pre-set value, typically 175 psi (12.1 bar).

**Pressure-resistant wall:** A wall that has been specifically designed and built to resist deformation due to an expected internal pressure build-up during a deflagration type of explosion. It is installed in combination with a pressure-relieving type of wall or ceiling to help ensure serious damage is not experienced to the room area of explosion origin.

**Priming water:** Water that is applied over the top of the internal clapper of an automatic system valve (i.e., dry-pipe valve, preaction valve, etc.) to help keep any rubber or similar components from drying out and causing possible failure of the valve.

**Quick-opening device:** An automatic device installed either on an automatic water control valve or within a sprinkler system whose purpose is to decrease the sprinkler system's trip time (and possibly the water travel time as well).

**Quick-response automatic sprinkler:** A sprinkler that, when submitted to a Plunge Tunnel Test, has a resulting Response Time Index (RTI) value that is typically equal to or less than  $90 \text{ (ft}\cdot\text{s)}^{0.5}$  ( $50 \text{ [m}\cdot\text{s]}^{0.5}$ ) and a Conductivity factor that is equal to or less than  $1.81 \text{ (ft/s)}^{0.5}$  ( $1.0 \text{ [m/s]}^{0.5}$ ). See FM Approvals Standard Class 2000 for further details.

**Recessed automatic sprinkler:** A sprinkler in which part or most of the body of the sprinkler, other than the part that is connected to the sprinkler piping, is mounted within a recessed housing with the plane of the orifice above the plane of the ceiling, or behind the plane of the wall on which the sprinkler is mounted.

**Refrigerated-area sprinkler system:** A sprinkler system that is located downstream of a preaction valve and is equipped with closed-type sprinklers. The preaction valve is arranged to open only when a sprinkler operates and the heat-type detection system supervising the area being protected by the preaction sprinkler system activates (i.e., double-interlock type of preaction sprinkler system). This type of system is used in freezers due to the extremely low temperatures.

**Reliable automatic water supply:** A water source for a sprinkler system, and any connected manual extinguishing systems, that is installed and maintained in accordance with Data Sheet 3-10, *Private Fire Service Mains and Connections*. The water source must always be able to maintain an adequate volume of water for fire protection purposes. In addition, the integrated piping network that connects the water source to the sprinkler system must be arranged to always allow for water delivery to a sprinkler system.

**Reliable gas supply:** A gas supply used for filling a dry-pipe or preaction sprinkler system that is always available. If the air supply is reliant on electrical power, to be considered reliable, the power supply must be fed by either a secondary supply independent of the facility's primary electrical supply or from an emergency generator adequately sized to properly maintain the facility's fire protection requirements.

**Reliable heat source:** A heat source for a sprinkler system that is installed and maintained such that it can always (even during power outages) provide a sufficient heat output to prevent the freezing of any portion of a sprinkler system.

**Response time index (RTI):** A numerical value that represents the sprinkler's sensitivity to heat and is used to predict the response of a sprinkler in fire environments defined in terms of gas temperature and velocity versus time. It is represented in the following equation:

$$\text{RTI} = \tau \times (u)^{0.5}$$

where:

$\tau$  is time constant of the heat responsive element, and  
 $u$  is the gas velocity

Sprinklers having an RTI value of  $90 \text{ (ft}\cdot\text{s)}^{0.5}$  ( $50 \text{ [m}\cdot\text{s]}^{0.5}$ ) or less are considered quick-response type sprinklers. Sprinklers having an RTI value of  $145 \text{ (ft}\cdot\text{s)}^{0.5}$  ( $80 \text{ [m}\cdot\text{s]}^{0.5}$ ) or more are considered standard-response type sprinklers. Sprinklers having an RTI value between those values indicated for quick-response and standard-response sprinklers are called special-response type sprinklers.

**Restriction orifice:** An orifice separating two air pressure chambers within an accelerator. The orifice is large enough to allow slowly developing air pressure differentials between the two chambers to equalize, but it is too small to allow such an equilibrium state when the air pressure differential between the two chambers is developed relatively fast, such as in the event of a sprinkler actuation. The subsequent imbalance in pressure between the two air chambers is what causes the accelerator to activate.

**Return bend:** A combination of piping and fittings (typically elbows) that connect the top of a branch line to a sprinkler or another pipe that feeds sprinklers. They are typically used in sprinkler systems that are fed from raw water type sources to help avoid the accumulation of sediment in any drop nipples.

**Ridge vent:** An air exhaust vent installed at the peak of a roof.

**Riser nipple:** A vertical piece of pipe that connects a main to a branch line.

**Roller-Type Conveyor:** A conveying system that uses a cylindrically shaped roller over which a product is moved from one area of a facility to another area. These types of conveying systems can be an obstruction to sprinkler discharge depending on how far apart horizontally the rollers are positioned. See Section 2.5.2.5.9 for Nonstorage sprinklers or Section 2.5.4.5.9 for Storage sprinklers for additional information.

**Schedule pipe:** A rating assigned to a sprinkler pipe based on its wall thickness.

**Section properties of the members:** The properties of a secondary roof member (i.e., purlin) defined by its Cross-Sectional Area (A), Moment of Inertia (I), Section Modulus (S) and its Radius of Gyration (r). Base the actual purlin load carrying capacity on effective section properties, which account for local buckling in the cross-section of the purlin.

**Shield anchor:** A two-part fastener consisting of an expansion shield that is inserted into a predrilled hole and a lag bolt.

**Sidewall automatic sprinkler:** A sprinkler intended for installation near a wall and ceiling interface and designed to discharge water horizontally outward and onto adjacent walls as well as the protected area.

**Single-path flow:** Waterflow through a section of sprinkler piping that is in one direction only.

**Single-interlock preaction system:** A sprinkler system that is located downstream of a preaction valve and is equipped with closed-type sprinklers. The preaction valve is arranged to open upon the actuation of a detection system that is supervising the area being protected by the preaction sprinkler system.

**Smooth ceiling:** A ceiling having an even and regular surface that is free from indentations and/or protrusions.

**Solid ceiling:** A solid ceiling, for the purpose of allowing sprinklers installed below the ceiling to activate in a timely fashion, is mostly void of any openings but can have some openings, provided they do not exceed 4 ft<sup>2</sup> (0.4 m<sup>2</sup>) in size, and are either (1) separated horizontally from the nearest opening by a minimum of 5 ft (1.5 m), or (2) cumulatively, they do not exceed 30 ft<sup>2</sup> (2.8 m<sup>2</sup>) in size over a 100 ft<sup>2</sup> (9.3 m<sup>2</sup>) area.

**Solid mezzanine:** A mezzanine that does not consist of uniform openings that constitute at least 70% of the mezzanine area.

**Solid-type conveyor:** A conveying system that uses a solid moving platform to move products from one area of a facility to another area. These types of conveying systems can be an obstruction to sprinkler discharge depending on how wide the solid moving platform is. See Section 2.5.2.5.9 for Nonstorage sprinklers or Section 2.5.4.5.9 for additional information.

**Solid walkway:** A walkway that does not consist of uniform openings that constitute at least 70% of the walkway area.

**Spare automatic sprinklers:** Sprinklers that are maintained on site within a clearly marked dedicated cabinet or box for allowing prompt replacement of any existing sprinkler that has either operated or has been damaged.

**Special protection sprinklers:** Sprinklers that are used for the protection of special non-room types of environments, such as anechoic chambers, combustible concealed spaces, internal ductwork, cooling towers, oil-filled transformers, exterior exposed walls, and windows and cornices.

**Special-response automatic sprinkler:** A sprinkler that, when submitted to a Plunge Tunnel Test, has a resulting Response Time Index (RTI) value that is greater than 90 (ft·s)<sup>0.5</sup> (50[m·s]<sup>0.5</sup>) and less than 145 (ft·s)<sup>0.5</sup> (80 [m·s]<sup>0.5</sup>). FM Approvals Standards Class 2000 and Class 2008 do not currently recognize this type of sprinkler response rating.

**Specifications:** A listing of the specific equipment and/or components that is to be installed in a sprinkler system. It could also be detailed information regarding the construction and/or occupancy of the area to be protected by sprinklers to validate the compatibility and effectiveness of the sprinkler system based on the details provided.

**Spray nozzle:** A piece of fire protection equipment through which water is automatically discharged with the intent of either controlling or suppressing a fire. A spray nozzle is like a sprinkler; however, it usually is void of an orifice cap and a deflector, and discharges water at a high velocity in a spray pattern that is void of air pockets.

**Sprig:** The piece of pipe that connects the branch line to a sprinkler located directly above the branch line. Note that sprigs are no longer required in this data sheet.

**Sprinkler system components:** The various materials and products that constitute a sprinkler system. They include but are not limited to sprinklers, sprinkler piping, automatic water control valves, check valves and pressure gauges.

**Sprinkler system pipe connections:** How two pieces of sprinkler pipe are connected. Connections can consist of couplings, fittings, flanges or by an acceptable welding process.

**Sprinkler system piping:** The combination of sprinkler pipe, couplings and fittings that together allow water to be fed from the base of the sprinkler system's riser to the sprinklers that are installed on the sprinkler system.

**Sprinkler system riser:** It is the vertical piping network of a sprinkler system that connects the sprinkler system's water supply (typically the underground water supply piping network) to the sprinkler system's feed main. It is equipped with the sprinkler system's waterflow alarm device as well as a pressure gauge and a drain valve. Other auxiliary equipment typically provided on the sprinkler system riser includes a relief valve and the attachment point of the fire service connection.

**Sprinkler system strainer:** A device that is installed within a sprinkler system to help prevent the flow of foreign debris, such as grit, stones, leaves, etc., beyond it. It is typically required in sprinkler systems equipped with small K-factor sprinklers.

**Sprinkler system's system valve:** It is the automatic valve provided on the sprinkler system riser to which the waterflow alarm device, pressure gauge(s) and drain valve are connected (i.e., alarm check valve on a wet sprinkler system; dry-pipe valve on a dry sprinkler system; etc.).

**Standard-response automatic sprinkler:** A sprinkler that, when submitted to a Plunge Tunnel Test, has a resulting Response Time Index (RTI) value that is typically equal to or greater than  $145 \text{ (ft}\cdot\text{s)}^{0.5}$  ( $80 \text{ [m}\cdot\text{s]}^{0.5}$ ) but not exceeding  $635 \text{ (ft}\cdot\text{s)}^{0.5}$  ( $350 \text{ [m}\cdot\text{s]}^{0.5}$ ) and a Conductivity factor that is equal to or less than  $3.62 \text{ (ft/s)}^{0.5}$  ( $2.0 \text{ [m/s]}^{0.5}$ ). See FM Approvals Standard Class 2000 for further details.

**Standard-spray automatic sprinkler:** A sprinkler with a deflector designed to discharge nearly all its water down toward the protected area. This type of sprinkler has been common since 1953. Today, it is commonly referred to as a Control Mode Density Area (CMDA) sprinkler outside of FM terminology and is considered a type of Nonstorage sprinkler using FM terminology.

**Storage arrangement:** The way a stored commodity is maintained. Typical storage arrangements include solid-piled, palletized, shelf, bin-box, movable shelving units, fixed storage racks and portable racks.

**Storage automatic sprinkler:** A sprinkler that has been categorized by FM as acceptable for protecting storage-type occupancies and/or any other high heat-release type fires as permitted in an occupancy-specific data sheet.

**Storage-type occupancy:** An occupancy consisting of combustible or noncombustible materials that are maintained in a storage arrangement covering a minimum area of  $200 \text{ ft}^2$  ( $18.5 \text{ m}^2$ ) and have a minimum height of 5 ft (1.5 m) for commodity hazards that are plastic or worse (flammable liquids, flammable gasses, roll paper, rubber tires, etc.) in content, or have a minimum height of 10 ft (3.0 m) for commodity hazards that are cellulosic or less hazardous in content.

**Structural concrete:** Concrete that has a unit weight equal to or greater than  $115 \text{ lb/ft}^3$  ( $1,840 \text{ kg/m}^3$ ).

**Structural member:** An integral piece of construction material that is used to support a roof, floor, or mezzanine. It is typically arranged in a vertical orientation. Examples of structural members include beams, concrete tees, girders, joists, purlins, and trusses.

**Supplemental sprinkler:** A sprinkler that is installed below an object when the location and size of the object results in an unacceptable obstruction to the discharge pattern of a ceiling-level sprinkler.

**Tamper alarm:** A device that is installed on a manually operated sprinkler system control valve that will provide an alarm condition if the valve stem is not located in the proper location (i.e., fully open, or fully closed).

**Threaded pipe:** A piece of sprinkler piping in which at least one of the ends of the pipe has been fabricated with an acceptable standardized thread style to allow the pipe to be connected to another sprinkler piping via a threaded fitting.

**Transverse flue space:** A vertical space, located between materials maintained in a storage arrangement, that is perpendicular to the loading aisle. Such flue spaces are typically found in storage racks.

**Trip test:** A test involving a sprinkler system equipped with an automatic system valve to ensure that (a) the valve functions properly, (b) that the minimum required system pressure is achieved within the permissible timeframe, (c) that all detection and components used for activating the automatic system valve operate properly, and (d) that all interlocks provided on the sprinkler system operate as expected. See Data Sheet 2-81, *Fire Safety Inspections and Sprinkler System Maintenance*, for additional information regarding procedures and documentation needed as part of a trip test.

**Trip time:** The time interval, measured in seconds, between the following two events:

- A. The point in time when the most hydraulically remote sprinkler on a dry-pipe, preaction, or similar type of sprinkler system equipped with an automatic system valve opens, and
- B. The point in time when the automatic system valve for the sprinkler system opens, allowing water to enter the sprinkler system.

**Ultimate strength:** The load value at which a material will fail.

**Undercut fastener:** A concrete fastener that utilizes a single-piece bolt and expansion sleeve that is inserted into a predrilled inverted cone-shaped hole.

**Unobstructed ceiling construction:** A ceiling structural assembly that allows the flow of hot gases to spread out under the ceiling in a uniform fashion from the point of fire origin, when centered within a ceiling channel, to the nearest four sprinklers in a timely fashion. Examples of ceilings that meet this definition include:

- A. Ceilings with structural members that have a maximum vertical depth of 4 in. (100 mm), or
- B. Ceilings with structural members that have a minimum open cross-sectional area of 70%, or
- C. Ceiling channels where the horizontal distance between the structural members is greater than the minimum allowable linear spacing for the sprinkler being installed (i.e., 2 lines of sprinklers can be installed within the ceiling channel).

Ceiling structural assemblies that do not meet the examples above for unobstructed ceiling construction would generally be classified as obstructed ceiling construction.

**Upright automatic sprinkler:** A sprinkler where the water discharge from the sprinkler orifice is directed vertically upward toward the deflector, which in turn redirects the water downwards toward the protected area. The sprinkler is designed to have the deflector oriented vertically above the pipe to which the sprinkler is connected.

**Vacuum sprinkler system:** A sprinkler system that is located downstream of a preaction valve, is equipped with closed-type sprinklers, and is maintained under a negative pressure. It can be arranged to be either a non-interlock, single-interlock, or double-interlock type of sprinkler system.

**Vertical distance:** Vertical distance between the centerline of the sprinkler's thermal element to the uppermost portion of the underside of the ceiling.

**Vertical sidewall automatic sprinkler:** A sidewall-type sprinkler where the sprinkler orifice is in a vertical plane relative to the protected area.

**Walkway:** An elevated passageway that is intended for personnel use. In this data sheet, the walkway is expected to be void of any storage or mechanical equipment, and typically will not be wider than 10 ft (3.0 m).

**Wall post indicator valve:** A manually operated fire service gate valve that controls the water supply to a sprinkler system. Manual access is provided to the valve by positioning the control handle on the opposite side of a nearby wall or barrier. The valve is equipped with target indicator, visible through an opening in the post, which is provided to show whether the valve is open or shut.

**Wall-mounted sidewall automatic sprinkler:** A sidewall-type sprinkler that is connected to sprinkler piping that is located along and supported by a wall of the protected area. Special care is needed for such sprinklers to ensure they do not rotate upon sprinkler actuation.

**Water delivery time:** The time interval, measured in seconds, of both the trip time and the water travel time of a sprinkler system. It can also be defined as the time interval, in seconds, between the following two events:

- A. The point in time when the most hydraulically remote sprinkler on a dry-pipe, preaction, or similar type of sprinkler system equipped with an automatic system valve opens, and
- B. The point in time when pressure at the most remote sprinkler reaches or surpasses the design pressure for the sprinkler system.

**Waterflow alarm:** A device that is installed on a sprinkler system and arranged to provide an alarm when one or more sprinklers operate.

**Water travel time:** The time interval, measured in seconds, between the following two events:

- A. The point in time when the water control valve for the sprinkler system opens, allowing water to enter the sprinkler system, and
- B. The point in time when pressure at the most remote sprinkler reaches or surpasses the design pressure for the sprinkler system.

**Wet-pipe sprinkler system:** The portion of a sprinkler system that is located downstream of the base of a sprinkler system riser and is filled with water.

**Wind bracing:** See the definition for Bridging.

**Working drawings:** Sprinkler drawings that are developed and utilized by a contractor for installing a sprinkler system.

**Yard main:** The network of underground piping, located within the property lines of the protected facility, that supplies water to the sprinkler system.

**Yield strength:** The load value at which a material begins to deform plastically (i.e., does not return to its original shape when the load is removed).

**Z-shaped steel secondary roof member (purlin):** A thin, usually 0.058 to 0.120 in. (1.5 to 3.0 mm) thick, solid web, cold-formed steel secondary member (directly supports deck) that is formed in the shape of the letter Z. It usually varies in depth from 8 to 11.5 in. (200 to 290 mm) but may range from 6.5 to 14.5 in. (165 to 368 mm). See Data Sheet 1-31, *Metal Roof Systems*, for further details.

## APPENDIX B DOCUMENT REVISION HISTORY

The purpose of this appendix is to capture the changes that were made to this document each time it was published. Please note that section numbers refer specifically to those in the version published on the date shown (i.e., the section numbers are not always the same from version to version).

**April 2026. Interim revision. The following modifications were incorporated into this edition of the data sheet:**

- A. Section 2.5.1.1.2 on minimum design pressures for sprinklers has been updated based on recent testing. It also now includes the minimum design pressure for all FM Approved sprinklers.
- B. Table 2.5.4.5.4.1, which provides guidance on the acceptable location of obstructing objects from nearby ceiling sprinklers, has been revised to better clarify the guidelines provided in the third column of the table.
- C. Sections 2.5.4.5.4 and 2.5.4.5.5 have been modified to pull all the guidance from Section 2.5.4.5.5 specific to obstructing objects no wider than 2 ft (0.6 m) and relocate them into Section 2.5.4.5.4.
- D. Section 2.4.1.1.5.2 has been updated to indicate that FM Approved stretched-reduced mill manufactured steel pipe can be installed without consideration for the weld line's alignment relative to the floor.

**April 2025. Interim revision. The following modifications were incorporated into this revision:**

- A. The guidelines for when sprinkler protection is recommended within ceiling pockets has been updated.
- B. Editorial changes have been introduced to better clarify the recommendations offered in this data sheet.

**January 2024.** Interim revision. The following modifications were incorporated into this edition of the data sheet:

- A. The term “supplemental sprinkler” was introduced as a sprinkler which is added below an obstruction to ceiling-level sprinkler discharge. In addition, the design and installation of supplemental sprinklers that have different attributes than the obstructed ceiling-level sprinklers can now be accommodated.
- B. The recommended minimum wall thickness of sprinkler piping for various types of pipe connections has been updated.
- C. The recommendations for ceiling-level sprinklers installed in the presence of plastic skylights, ridge vents and ceiling-level natural draft exhaust vents have been modified and relocated to the specific section for the ceiling sprinkler being installed.
- D. The minimum recommended design pressures for sprinklers have been relocated into this data sheet.
- E. Roller type conveyors over a nonstorage-type occupancy are no longer considered an unacceptable obstruction to ceiling-level sprinklers.
- F. Editorial changes have been introduced to better clarify the recommendations offered in this data sheet.

**July 2023.** Interim revision. Figure 2.5.1.3.1 was modified to account for recent test results involving gravity heat/smoke vents and is now listed as Figure 2.5.1.3.1(a) for non-storage applications, and Figure 2.5.1.3.1(b) for storage applications.

Appendix A was updated to provide clarifying definitions for both gravity heat/smoke vents and mechanically operated smoke vents.

**October 2021.** Full revision. Significant changes include the following:

- A. Incorporated the sprinkler installation recommendations from Data Sheet 8-29, *Refrigerated Storage*.
- B. Incorporated most of the sprinkler and water spray protection recommendations from Data Sheet 1-23, *Fire Barriers and Protection of Openings*.
- C. Reorganized this data sheet to better reflect the way a sprinkler contractor would determine the installation of a sprinkler system.
- D. Updated the guidance for obstructed ceiling construction based on recent testing.
- E. Updated the guidance for ceiling based on recent testing.
- F. Updated the guidance for objects below a sprinkler that could result in sprinkler discharge obstruction based on recent testing.
- G. Revised the guidance on hanging and bracing sprinkler pipe.
- H. Removed the terms “inner core discharge pattern” and “umbrella discharge pattern” from this data sheet.
- I. Added a new flowchart to help the user navigate to the appropriate sections of this data sheet.
- J. Made extensive editorial revisions.

**October 2020.** Interim revision. Clarifications were made to Table 5, *Spacing of Ceiling-Level Pendant and Upright Nonstorage Sprinklers for Hazard Category No. 3* and Figures 8, 9, 15, 16, 31 and 32 were modified.

**January 2018.** Interim revision. Changes to Data Sheet 2-0 include the following:

- A. Guidance has been incorporated for the installation requirements of vacuum-type sprinkler systems, which have recently become Approved.
- B. The ceiling-level sprinkler spacing requirements have been updated for Nonstorage sprinklers based on recent changes to Data Sheet 3-26, *Fire Protection for Nonstorage Occupancies*.
- C. Guidance in Sections 2.1.3.2.3 and 2.2.3.3 was modified by changing “greater than 90°” and “less than or equal to 90°” to “greater than or equal to 90°” and “less than 90°”.

**January 2014.** Correction was made to Table 24, Maximum Distance Between Pipe Hangers.

**April 2011.** Further clarification was made to the guidelines for a sprinkler system's area limitation (Section 2.4.1.6, Sprinkler System Maximum Area of Coverage).

**January 2011.** Modifications were made to the following: Tables 3, 4, 5 and 17, and Sections 2.4.1.6, 2.4.3.7 and 2.5.2.4.

**March 2010.** This is the first publication of this document.

Advanced Copy. January 2010. This is the first publication of this document. However, changes have been made to the following subject areas previously covered in Data Sheets 2-2, 2-7, or 2-8N, which this document supersedes:

- Sprinklers located under open-grid mezzanines and walkways (see Sections 2.1.1.4 for Nonstorage sprinklers or 2.2.1.4 for Storage sprinklers)
- Acceptable ceiling slopes in the presence of various ceiling-level sprinklers (see Sections 2.1.1.6 for Nonstorage sprinklers or 2.2.1.6 for Storage sprinklers)
- Heat and/or smoke vents, as well as other exhaust openings at ceiling level (see Sections 2.1.1.7 for Nonstorage sprinklers or 2.2.1.7 for Storage sprinklers)
- The maximum recommended area of coverage for each sprinkler system (see Section 2.4.1.6)
- The requirements for dry-pipe sprinkler systems (see Section 2.4.3)
- The requirements for antifreeze solution sprinkler systems (see Section 2.4.7)
- The number of spare sprinklers recommended for each sprinkler system (see Sections 2.1.3.1.7 for Nonstorage sprinklers and 2.2.3.1.6 for Storage sprinklers)
- The allowable linear and area spacing of ceiling-level sprinklers (see Sections 2.1.3.2.2 for Nonstorage sprinklers, 2.1.3.3.2 for sidewall Nonstorage sprinklers or 2.2.3.2 for Storage sprinklers)
- The guidelines for objects that obstruct sprinklers (ceiling and in-rack) protecting storage occupancies (see Section 2.2.3.5)
- The guidelines for the support of sprinkler piping, including field testing of concrete fasteners (see Section 2.5.4). In addition, the following changes have been made:
- This data sheet contains no references to local codes.
- Sprinklers are no longer required to be added to hydraulic calculations when installed to mitigate obstructed ceiling sprinklers.
- The terms "Control Mode Density Area (CMDA)," "Control Mode Specific Application (CMSA)," and "Suppression Mode" are no longer used to describe sprinklers.
- The terms "Storage," "Nonstorage," and "Special Protection" are now used to describe sprinklers (see Appendix A, Glossary of Terms, for definitions).
- The definition of an "individual object" (for obstruction purposes) has been modified: the horizontal distance between the potential obstruction and the nearest object has been changed from more than 6 times to more than 3 times the object's least dimension.

## APPENDIX C FORMS

FM Forms FM85A and FM999C are provided on the following pages.

**FM Contractor's Material & Test Certificate for Automatic Sprinkler Systems**



*Additional printed copies of this form are available to clients from:  
Communication Services, FM, 270 Central Avenue, Johnston, RI 02919*

**Procedure:** Upon completion of work, inspection and tests shall be made by the contractor's representative and witnessed by an owner's representative. All defects shall be corrected and system left in service before contractor's personnel finally leave the job.

A certificate shall be filled out and signed by both representatives. Copies shall be prepared for approving authorities, owners and contractor. It is understood the owner's representatives signature in no way prejudices any claim against the contractor for faulty material, poor workmanship or failure to comply with approving authority's requirements or local ordinances.

<b>Contractor Information</b>					Date: <input type="text"/>	
Contractor Company Name: <input type="text"/>						
Contractor Company Address: <input type="text"/>						
<hr/>						
<b>FM Global Client Information</b>			FM Global Index No.: <input type="text"/>		FM Global Account No.: <input type="text"/>	
FM Global Client Building Owner or Tenant (Y/N)? <input type="text"/>				Building Name or No.: <input type="text"/>		
FM Global Client Name: <input type="text"/>						
FM Global Client Address: <input type="text"/>						
Description of Occupancy Being Protected: <input type="text"/>						
<b>Automatic Sprinkler System Components and Materials</b>						
<b>Automatic Sprinklers:</b>						
Manufacturer	Model / Trade Name	K-Factor	Temperature Rating	SIN	Year of Manufacture	Quantity
<input type="text"/>	<input type="text"/>	<input type="text"/>	<input type="text"/>	<input type="text"/>	<input type="text"/>	<input type="text"/>
<input type="text"/>	<input type="text"/>	<input type="text"/>	<input type="text"/>	<input type="text"/>	<input type="text"/>	<input type="text"/>
<input type="text"/>	<input type="text"/>	<input type="text"/>	<input type="text"/>	<input type="text"/>	<input type="text"/>	<input type="text"/>
<input type="text"/>	<input type="text"/>	<input type="text"/>	<input type="text"/>	<input type="text"/>	<input type="text"/>	<input type="text"/>
<input type="text"/>	<input type="text"/>	<input type="text"/>	<input type="text"/>	<input type="text"/>	<input type="text"/>	<input type="text"/>
<input type="text"/>	<input type="text"/>	<input type="text"/>	<input type="text"/>	<input type="text"/>	<input type="text"/>	<input type="text"/>
<input type="text"/>	<input type="text"/>	<input type="text"/>	<input type="text"/>	<input type="text"/>	<input type="text"/>	<input type="text"/>
<b>Automatic Sprinkler Pipe:</b>						
Manufacturer	Model / Trade Name	Product Description	Schedule	Connection Type	Max. Working Pressure	
<input type="text"/>	<input type="text"/>	<input type="text"/>	<input type="text"/>	<input type="text"/>	<input type="text"/>	
<input type="text"/>	<input type="text"/>	<input type="text"/>	<input type="text"/>	<input type="text"/>	<input type="text"/>	
<input type="text"/>	<input type="text"/>	<input type="text"/>	<input type="text"/>	<input type="text"/>	<input type="text"/>	
<input type="text"/>	<input type="text"/>	<input type="text"/>	<input type="text"/>	<input type="text"/>	<input type="text"/>	

**FM Contractor's Material & Test Certificate for Automatic Sprinkler Systems**

*Additional printed copies of this form are available to clients from:  
Communication Services, FM, 270 Central Avenue, Johnston, RI 02919*



**Automatic Sprinkler System Components and Materials (cont.)**

**Automatic Sprinkler Pipe Connection:**

Manufacturer	Model / Trade Name	Product Description	Pipe Ends	Max. Working Pressure

**Automatic Sprinkler Pipe Hangers:**

Manufacturer	Model / Trade Name	Product Description	Hanger Rod Size	Component Description	Nominal Pipe Size

**Automatic Sprinkler System Alarm-Check, Dry-Pipe or Automatic-Release Type Valves:**

Type	Manufacturer	Model	Serial Number	Quantity

**If Automatic-Release Type Valve:**

Is the detection electronic, hydraulic and/or pneumatic?

Is the interlock arrangement single, double or non-interlock?

Is the air pressure in the system piping supervised?

Is the Automatic-Release Valve arranged for manual operation?

**Detection for Automatic-Release Type Valves:**

Type	Manufacturer	Model	Protected Area	Linear Spacing	Area Spacing	Quantity

**If the Detection for Automatic-Release Type Valve is electric:**

Is the circuitry supervised in accordance with Data Sheet 5-40?

What is make and model of Automatic Release Control Panel?

What is make and model of Solenoid Release Valve?

**FM Contractor's Material & Test Certificate for Automatic Sprinkler Systems**

*Additional printed copies of this form are available to clients from:  
Communication Services, FM, 270 Central Avenue, Johnston, RI 02919*



**Automatic Sprinkler System Components and Materials (cont.)**

**Automatic Sprinkler System Control or Pressure-Reducing Type Valves:**

Type	Manufacturer	Model	Serial Number	Quantity

**Automatic Sprinkler System Check or Backflow Preventer Type Valves:**

Type	Manufacturer	Model	Serial Number	Quantity

**Automatic Sprinkler System – Miscellaneous Components:**

Component	Manufacturer	Model	Quantity
Waterflow Alarm			
Quick Opening Device			
Pressure Gauge			
Fire Department Connection			
Relief Valve			
Test Connection			
Drain Valve			

**Automatic Sprinkler System – Other Components:**

Component	Manufacturer	Model	Quantity

## FM Contractor's Material & Test Certificate for Automatic Sprinkler Systems

Additional printed copies of this form are available to clients from:  
 Communication Services, FM, 270 Central Avenue, Johnston, RI 02919



### Automatic Sprinkler System Tests

**Hydrostatic Tests:** Hydrostatic tests shall be conducted at not less than 200 psi (13.8 bar) or 50 psi (3.5 bar) above any static pressure in excess of 150 psi (10.3 bar) for 2 hours. Hydrostatically test any anti-freeze solution sprinkler systems equipped with pendent sprinklers with the anti-freeze solution being used. Differential dry-pipe valves clappers shall be left open during the test to prevent damage. Modify the automatic sprinkler as needed to ensure there is no pressure drop over the 2 hour timeframe.

The sprinkler piping for all wet-pipe automatic sprinkler systems as well as anti-freeze solution automatic sprinkler systems equipped with pendent sprinklers have been hydrostatically tested at \_\_\_\_\_ psi for \_\_\_\_\_ hours with \_\_\_\_\_ psi drop.

**Pneumatic Tests:** Pneumatic tests shall be conducted at close to, but not exceeding, 40 psi (2.8 bar) air pressure. Ensure pressure tanks are arranged for their normal water level and air pressure conditions. Modify the automatic sprinkler system as needed to ensure there is no more than a 1.5 psi (0.1 bar) pressure drop over a 24 hour timeframe.

The sprinkler piping for all dry-pipe and similar automatic sprinkler systems have been pneumatically tested at \_\_\_\_\_ psi for \_\_\_\_\_ hours with \_\_\_\_\_ psi drop.

**Waterflow Alarm Tests:** Tests shall be conducted on all automatic sprinkler system alarm devices to ensure that an alarm signal is activated no more than 60 seconds after initiating waterflow through the Inspector's Test Connection or similar device.

A total of \_\_\_\_\_ waterflow alarm devices were tested. A total of \_\_\_\_\_ waterflow alarm devices activated an alarm signal in more than 60 seconds.

### Dry Pipe System or Automatic-Release Type System Testing:

Time to Achieve Minimum Required Sprinkler Pressure

System No./Name	Water Pressure Below Valve	System Air Pressure	Min. Pressure Req. at Sprinkler	Required Water Delivery Time	Time to Achieve Minimum Required Sprinkler Pressure	
					Without Q.O.D.	With Q.O.D.

### If Automatic-Release Type Valve:

Was valve operated manually as well as automatically? \_\_\_\_\_

If Detection is electronic, were all detection units tested? \_\_\_\_\_

### Pressure-Reducing Valve Testing:

Location	Make	Model	Setting	Static Pressure		Residual Pressure		Flow Rate
				Inlet	Outlet	Inlet	Outlet	

**FM Contractor's Material & Test Certificate for Automatic Sprinkler Systems**

*Additional printed copies of this form are available to clients from:  
Communication Services, FM, 270 Central Avenue, Johnston, RI 02919*



Automatic Sprinkler System Tests (cont.)			
<b>Blank Testing Gaskets:</b>			
Number Used	Location	Number Removed	
<input type="text"/>	<input type="text"/>	<input type="text"/>	
<input type="text"/>	<input type="text"/>	<input type="text"/>	
<input type="text"/>	<input type="text"/>	<input type="text"/>	
<b>Welded Pipe Connections:</b>			<b>Yes or No?</b>
Do you certify as the sprinkler contractor that the welding procedures used for the connection of sprinkler piping materials complied with the minimum requirements of AWS B2.1, ASME Section IX <i>Welding and Brazing Qualifications</i> , or other applicable qualification standards as required by the AHJ?			<input type="text"/>
Do you certify that all welding procedures used for the connection of sprinkler piping materials was conducted by welders or welding operators qualified in accordance with the minimum requirements of AWS B2.1, ASME Section IX <i>Welding and Brazing Qualifications</i> , or other applicable qualification standards as required by the AHJ?			<input type="text"/>
Do you certify that the welding was carried out in compliance with a documented quality control procedure to ensure that all discs and field-cut pipe coupons were retrieved from the sprinkler system piping, that openings in piping are smooth, that slag and other welding residue were removed, and that internal diameters of piping were not penetrated?			<input type="text"/>
<b>Drain Tests:</b>			
System Name/No.	Static Pressure	Residual Pressure	Static Pressure Afterwards
<input type="text"/>	<input type="text"/>	<input type="text"/>	<input type="text"/>
<input type="text"/>	<input type="text"/>	<input type="text"/>	<input type="text"/>
<input type="text"/>	<input type="text"/>	<input type="text"/>	<input type="text"/>
<input type="text"/>	<input type="text"/>	<input type="text"/>	<input type="text"/>
<input type="text"/>	<input type="text"/>	<input type="text"/>	<input type="text"/>
<b>Underground Mains:</b>			
<b>All underground mains and lead-in connections to automatic sprinkler system risers shall be flushed before connection is made to automatic sprinkler system piping.</b>			
Was this verified on Form FM85B? <input type="text"/>		If No, what form was used? <input type="text"/>	
What contractor flushed the underground mains and lead-ins? <input type="text"/>			

**FM Contractor's Material & Test Certificate for Automatic Sprinkler Systems**



*Additional printed copies of this form are available to clients from:  
Communication Services, FM, 270 Central Avenue, Johnston, RI 02919*

Automatic Sprinkler System Tests (cont.)	
<b>Instruction Materials:</b>	<b>Yes or No?</b>
Has the person in charge of the fire equipment been instructed as to the location of all the automatic sprinkler system control valves and the care and maintenance of this new equipment?	<input type="checkbox"/>
Have copies of the appropriate instructions and care of maintenance charts been left on the premises?	<input type="checkbox"/>
If the answer to either of these questions is "No", explain:	
<input type="checkbox"/>	
Date Sprinkler System Left in Service with All Control Valves Open: <input type="checkbox"/>	
<b>Signatures:</b>	
The Property Owner or their authorized agent: <input type="checkbox"/>	
Signature and Title <input type="checkbox"/>	Date <input type="checkbox"/>
The Sprinkler Contractor: <input type="checkbox"/>	
Signature and Title <input type="checkbox"/>	Date <input type="checkbox"/>
<b>Additional Explanations, Comments and/or Notes:</b>	
<input type="checkbox"/>	



## FM's contractor's hydraulic analysis certificate for automatic sprinkler systems

<b>Contractor information</b>	Drawing no.: <input type="text"/>	Date: <input type="text"/>
Contractor company name: <input type="text"/>		
Contractor company address: <input type="text"/>		
Hydraulic analysis conducted by: <input type="text"/>		

<b>FM client information</b>	FM index no.: <input type="text"/>	FM account no.: <input type="text"/>
FM client building owner or tenant (Y/N)? <input type="text"/>	Building name or no.: <input type="text"/>	
FM client name: <input type="text"/>		
FM client address: <input type="text"/>		
Description of occupancy being protected: <input type="text"/>		

<b>Protection required: ceiling sprinkler system design</b>			
FM data sheet used: <input type="text"/>	Table/figure used: <input type="text"/>	Demand area shape factor: <input type="text"/>	
Ceiling sprinkler system design requirements: <input type="text"/>			
Hose demand: <input type="text"/>	Table/figure used: <input type="text"/>	Duration: <input type="text"/>	Table/figure used: <input type="text"/>
Steel protection required per data sheet: <input type="text"/>	Overhead steel (Y/N)? <input type="text"/>	Steel columns (Y/N)? <input type="text"/>	
Ceiling sprinkler system flow and pressure required at BOR: <input type="text"/>			
If not at BOR, describe location: <input type="text"/>			

<b>Ceiling sprinkler system information</b>			
Ceiling sprinkler system name and/or number: <input type="text"/>			
Sprinkler system type: <input type="text"/>	System volume: <input type="text"/>	Schedule of pipe: <input type="text"/>	
Sprinkler manufacturer: <input type="text"/>	Sprinkler model: <input type="text"/>	Sprinkler SIN: <input type="text"/>	
Sprinkler type: <input type="checkbox"/> Storage <input type="checkbox"/> Non-storage <input type="checkbox"/>	Special protection <input type="checkbox"/>		
Sprinkler RTI: <input type="checkbox"/> Standard-response <input type="checkbox"/> Quick-response <input type="checkbox"/>	Sprinkler temperature rating: <input type="text"/>		
Sprinkler K-factor: <input type="text"/>	Sprinkler on-line spacing: <input type="text"/>	Sprinkler between-line spacing: <input type="text"/>	
Sprinkler orientation: <input type="checkbox"/> Pendent <input type="checkbox"/> Upright <input type="checkbox"/> Other <input type="checkbox"/>			
If other, describe: <input type="text"/>			

FM's contractor's hydraulic analysis certificate for automatic sprinkler systems

Protection required: in-rack sprinkler system design		
FM data sheet used: <input type="text"/>	Table/figure used: <input type="text"/>	Demand area shape factor: <input type="text"/>
In-rack sprinkler system design requirements: <input type="text"/>		
Flow and pressure required at BOR or POC: <input type="text"/>		
If at POC, describe location: <input type="text"/>		

In-rack sprinkler system information		
In-rack sprinkler system name and/or number: <input type="text"/>		
Sprinkler system type: <input type="text"/>	System volume: <input type="text"/>	Schedule of pipe: <input type="text"/>
Sprinkler manufacturer: <input type="text"/>	Sprinkler model: <input type="text"/>	Sprinkler SIN: <input type="text"/>
Sprinkler type: <input type="text"/>	Storage <input type="checkbox"/>	Non-storage <input type="checkbox"/>
		Special protection <input type="checkbox"/>
Sprinkler RTI: <input type="text"/>	Standard-response <input type="checkbox"/>	Quick-response <input type="checkbox"/>
		Sprinkler temperature rating: <input type="text"/>
Sprinkler K-factor: <input type="text"/>	Sprinkler on-line spacing: <input type="text"/>	Sprinkler between-line spacing: <input type="text"/>
Sprinkler orientation: <input type="text"/>	Pendent <input type="checkbox"/>	Upright <input type="checkbox"/>
		Other <input type="checkbox"/>
If other, describe: <input type="text"/>		

Storage arrangement information		
Commodity hazard description: <input type="text"/>		
Cartoned (Y/N)? <input type="checkbox"/>	Encapsulated (Y/N)? <input type="checkbox"/>	Open-top combustible container (Y/N)? <input type="checkbox"/>
Storage height: <input type="text"/>	Ceiling Height: <input type="text"/>	
Storage arrangement: <input type="text"/>		
If rack storage: <input type="checkbox"/>	Rack bay width: <input type="text"/>	Rack bay depth: <input type="text"/>
		Rack bay height: <input type="text"/>
Aisle width: <input type="text"/>	Solid shelves (Y/N)? <input type="checkbox"/>	If yes, shelf area: <input type="text"/>
Additional storage information: <input type="text"/>		

Protection available		
Flow and pressure available to ceiling system at BOR (or other) after hose deduction: <input type="text"/>		
Density or pressure / demand area to ceiling system at BOR (or other) after hose deduction: <input type="text"/>		
Flow and pressure available to in-rack system at BOR (or other) after hose deduction: <input type="text"/>		
Flow or pressure / demand area to in-rack system at BOR (or other) after hose deduction: <input type="text"/>		
Duration available: <input type="text"/>		

Water supplies available						
Name of source 1: <input type="text"/>	Type of source: <input type="text"/>	Location of source 1: <input type="text"/>				
Date of test: <input type="text"/>	Effective point of test: <input type="text"/>					
Static/churn: <input type="text"/>	Flow 1: <input type="text"/>	Residual 1: <input type="text"/>	Flow 2: <input type="text"/>	Residual 2: <input type="text"/>	Flow 3: <input type="text"/>	Residual 3: <input type="text"/>
Name of source 2: <input type="text"/>	Type of source: <input type="text"/>	Location of source 2: <input type="text"/>				
Date of test: <input type="text"/>	Effective point of test: <input type="text"/>					
Static/churn: <input type="text"/>	Flow 1: <input type="text"/>	Residual 1: <input type="text"/>	Flow 2: <input type="text"/>	Residual 2: <input type="text"/>	Flow 3: <input type="text"/>	Residual 3: <input type="text"/>

FM's contractor's hydraulic analysis certificate for automatic sprinkler systems

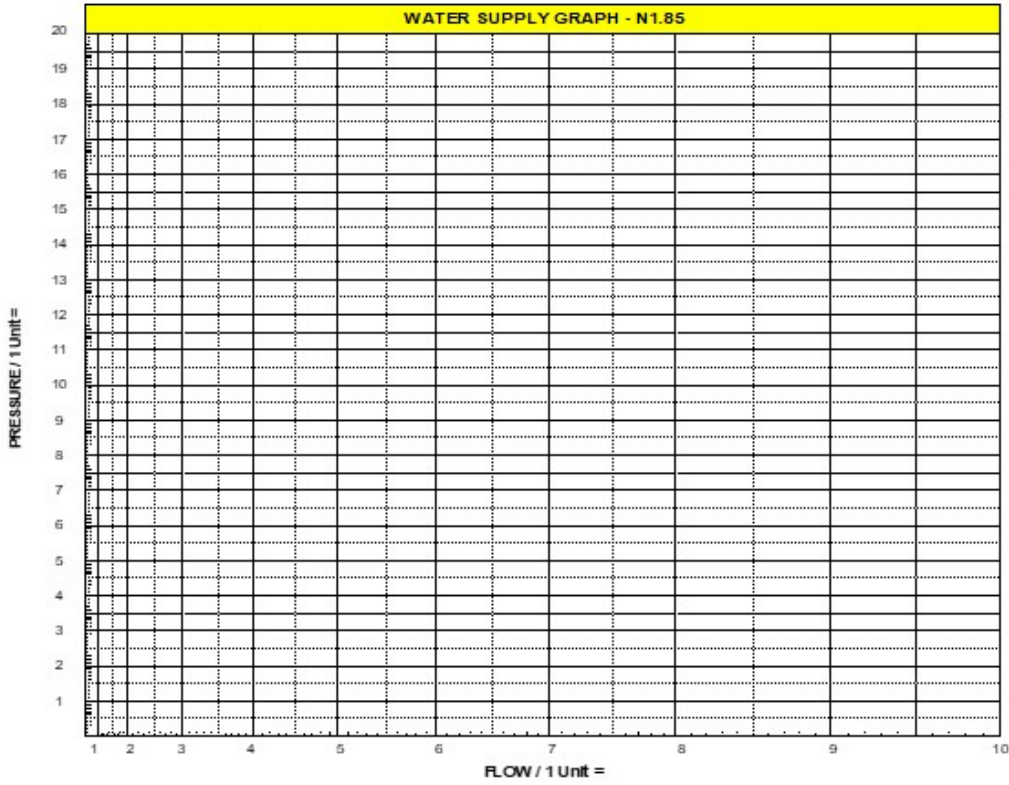

---

FM's contractor's hydraulic analysis certificate for automatic sprinkler systems

**Information to Include on the Water Supply Graph:**

- (1) **Ceiling System Demand Area Curve:** This is a curve representing the flow and pressure required for the ceiling sprinkler system that has been analyzed. Plot this curve using the following two points:
  - (a) The required flow and pressure for the automatic sprinkler system's design, and
  - (b) The required pressure due to elevation with no flow taking placeProvide an indication on this curve that represents the flow and pressure for the required design.
- (2) **In-Rack System Demand Area Curve (if applicable):** This is a curve representing the flow and pressure required for the in-rack sprinkler system that has been analyzed. Plot this curve using the following two points:
  - (a) The required flow and pressure for the automatic sprinkler system's design, and
  - (b) The required pressure due to elevation with no flow taking placeProvide an indication on this curve that represents the flow and pressure for the required design.
- (3) **Combined Ceiling and In-Rack System Demand Area Curve (if applicable):** This is a curve representing the flow and pressure required for both the ceiling and in-rack sprinkler systems, which have been analyzed, simultaneously. Plot this curve in two separate segments as follows:
  - (a) The first segment consists initially of only the In-Rack Sprinkler Demand Area Curve between zero flow and the flow that reaches the elevation pressure for the Ceiling System Demand Area Curve.
  - (b) The second segment consists of the combined flow between both the Ceiling System Demand Area Curve and the In-Rack System Demand Area Curve at any given pressure point.Provide an indication on this curve that represents the flow and pressure for the required combined design.
- (4) **Water Supply Curve Without Hose Stream Deduction:** This is a curve that represents the water supply available at the termination point of the hydraulic calculations for the automatic sprinkler system. For FM, this should be the base of the riser (BOR).
- (5) **Water Supply Curve With Hose Stream Deduction:** This is a curve that represents the water supply available at the termination point of the hydraulic calculations for the automatic sprinkler system after a required allotment of flow for hose stream usage has been deducted from the supply. For FM, the termination point for the hydraulic calculations should be the base of the riser (BOR). This curve is drawn by subtracting the required hose stream allowance, indicated in the FM occupancy-specific data sheet, from the water supply indicated in Item 4 above.

For examples on how to draw these curves, reference FM Data Sheet 3-0, *Hydraulics of Fire Protection Systems*.